

GANITA PRAKASH

TEXTBOOK OF MATHEMATICS



0889

विद्यया ऽ मृतमश्नुते



एन सी ई आर टी
NCERT

राष्ट्रीय शैक्षिक अनुसंधान और प्रशिक्षण परिषद्
NATIONAL COUNCIL OF EDUCATIONAL RESEARCH AND TRAINING

0889 – Ganita Prakash

Textbook of Mathematics for Grade 8 (Part-II)

ISBN 978-93-5729-106-4

First Edition

December 2025 Pausha 1947

PD 2500T BS

©National Council of Educational
Research and Training, 2025

₹ 65.00

Printed on 80 GSM paper with NCERT
watermark

Published at the Publication Division
by the Secretary, National Council of
Educational Research and Training,
Sri Aurobindo Marg, New Delhi 110 016
and printed at D.P. Printing & Binding,
B-149, Okhla-I, A-1, New Delhi-110020

ALL RIGHTS RESERVED

- ❑ No part of this publication may be reproduced, stored in a retrieval system or transmitted, in any form or by any means, electronic, mechanical, photocopying, recording or otherwise without the prior permission of the publisher.
- ❑ This book is sold subject to the condition that it shall not, by way of trade, be lent, re-sold, hired out or otherwise disposed of without the publisher's consent, in any form of binding or cover other than that in which it is published.
- ❑ The correct price of this publication is the price printed on this page. Any revised price indicated by a rubber stamp or by a sticker or by any other means is incorrect and should be unacceptable.

OFFICES OF THE PUBLICATION DIVISION, NCERT

NCERT Campus
Sri Aurobindo Marg
New Delhi 110 016 Phone : 011-26562708

108, 100 Feet Road
Hosdakere Halli Extension
Banashankari III Stage
Bengaluru 560 085 Phone : 080-26725740

Navjivan Trust Building
P.O.Navjivan
Ahmedabad 380 014 Phone : 079-27541446

CWC Campus
Opp. Dhankal Bus Stop
Panihati
Kolkata 700 114 Phone : 033-25530454

CWC Complex
Maligaon
Guwahati 781 021 Phone : 0361-2674869

Publication Team

Head, Publication : *M.V. Srinivasan*
Division

Chief Editor : *Bijnan Sutar*

Chief Business : *Amitabh Kumar*
Manager

Chief Production : *Deepak Jaiswal*
Officer (In charge)

Production Assistant : *Ashwani Machra*

Cover

Ritika B.

Illustrations

Chetan Sharma, Madhushree Basu

Layout

Creative Art Studio

FOREWORD

The National Education Policy (NEP) 2020 envisages a system of education in the country that is rooted in an Indian ethos, and its civilisational accomplishments in all fields of knowledge and human endeavour. At the same time, it aims to prepare students to engage constructively with the opportunities and challenges of the 21st century. The basis for this aspirational vision has been well laid out by the National Curriculum Framework for School Education (NCF-SE) 2023 across curricular areas at all stages. By nurturing students' inherent abilities across all five planes of human existence (*pañchakośhas*), the Foundational and Preparatory Stages set the Stage for further learning at the Middle Stage. Spanning Grades 6 to 8, the Middle Stage serves as a critical three-year bridge between the Preparatory and Secondary Stages.

The NCF-SE 2023, at the Middle Stage, aims to equip students with the skills that are needed to grow, as they advance in their lives. It aims to enhance their analytical, descriptive and narrative capabilities, and to prepare them for the challenges and opportunities that await them. A diverse curriculum, covering nine subjects ranging from three languages—including at least two languages native to India—to Science, Mathematics, Social Sciences, Art Education, Physical Education and Well-being, and Vocational Education promotes their holistic development.

Such a transformative learning culture requires certain essential conditions. One of them is to have appropriate textbooks in different curricular areas, as these textbooks are intended to play a central role in mediating between content and pedagogy's role that helps strike a judicious balance between direct instruction and opportunities for exploration and inquiry. Among the other conditions, classroom arrangement and teacher preparation are crucial to establish conceptual connections both within and across curricular areas.

The National Council of Educational Research and Training (NCERT), on its part, is committed to providing students with such high-quality textbooks. Various Curricular Area Groups (CAGs), which have been constituted for this purpose, comprising notable subject-experts, pedagogues, and practising teachers as their members, have made all possible efforts to develop such textbooks. *Ganita Prakash*, the mathematics textbook for Grade 8 (Part-II), is designed to make learning fun, engaging, and meaningful—just as in Part-I of the Grade 8 mathematics textbook. It continues to align with NEP 2020 and NCF-SE 2023, and fosters a spirit of experiential and inquiry-based learning, a spirit already introduced in the mathematics textbooks for earlier grades of the Middle Stage. The textbook encourages students to

ask questions, think critically, and understand mathematical concepts through real-world contexts.

The textbook strives to inspire students to observe and explore patterns around them and to discover mathematical ideas on their own. Its content is carefully structured to support a joyful and progressive understanding of increasingly complex concepts, helping students transition smoothly into more advanced learning. It also attempts to integrate mathematics with other subject areas, such as Science and Social Science, along with cross-cutting themes like environmental education, value education, inclusive education, and Indian Knowledge Systems (IKS). In most places, each concept begins with a story or a puzzle that not only stimulates students' thinking but also helps them appreciate the relevance and importance of the concept.

However, in addition to this textbook, students at this stage should also be encouraged to explore various other learning resources. School libraries play a crucial role in making such resources available. Besides, the role of parents and teachers will also be invaluable in guiding and encouraging students to do so.

With this, I express my gratitude to all those who have been involved in the development of this textbook, and hope that it will meet the expectations of all stakeholders. At the same time, I also invite suggestions and feedback from all its users for further improvement in the coming years.

New Delhi
December 2025

Dinesh Prasad Saklani
Director
National Council of Educational
Research and Training

ABOUT THE BOOK

Mathematics helps students develop not only basic arithmetic skills, but also the crucial capacities of logical reasoning, creative problem-solving, and clear and precise communication (both oral and written). Mathematical knowledge also plays a crucial role in understanding concepts in other school subjects, such as Science and Social Science, and even Arts, Physical Education, and Vocational Education. Learning Mathematics contributes to the development of capacities to make informed choices and decisions. Understanding numbers and quantitative arguments is necessary for effective and meaningful democratic and economic participation. Mathematics thus plays an important role in achieving the overall aims of school education.

Mathematics at the Middle Stage is a major challenge and performs the dual role of being both close to the experience and environment of a learner, and being abstract. It performs the role of developing intuition, while also maintaining and emphasising rigour. It is enhancing critical and logical thinking, while also developing artistry and creativity, and a sense of elegance and aesthetics. Mathematics provides students with plenty of opportunities to explore and discover concepts on their own, while also teaching the best-known methods in the global repertoire of mathematics.

This textbook of Mathematics, Grade 8 (Part-II) attempts to address the goals and challenges of learning mathematics. The writers have aimed to strike a judicious balance between informal and formal definitions, and methods in helping students to develop both intuition and rigour. The textbook also provides numerous opportunities for student-student and student-teacher interaction in the classroom to promote active and experiential learning. A number of questions, puzzles, and interactive exercises are posed throughout the textbook to encourage constant exploration. Many of the questions are open-ended to stimulate classroom discussion.

Chapter 1: 'Fractions in Disguise' introduces percentages and several applications. Chapter 2: 'The Baudhayana-Pythagoras Theorem' explores the relationship between the side lengths of a right-angled-triangle. Chapter 3: 'Proportional Reasoning-2' is a continuation of its counterpart in Grade 8 Part-I, which discusses making pie charts and introduces inverse proportions. Chapter 4: 'Exploring Some Geometrical Themes' focuses on 3D geometry and fractals. Chapter 5: 'Tales by Dots and Lines' gives a different perspective on the arithmetic mean, and introduces line graphs as part of visualising and interpreting data. Chapter 6: 'Algebra Play' explores how algebra can be used to model and understand different scenarios. Chapter 7: 'Area' delves deeper

into the areas of triangles and quadrilaterals. In all the chapters, an attempt has been made to emphasise connections with other subjects including Arts, Social Science and Science.

By weaving storytelling and hands-on activities together, as done in Grades 6 and 7, we hope that an immersive learning experience will be created that ignites curiosity and fosters a love for mathematics. It is hoped that teachers would give students the opportunity to discuss, play, engage with each other and provide logical arguments for different ideas, and find loopholes in arguments presented. This is necessary for the learners to eventually develop the ability to understand what it means to prove something and also become confident about the underlying concepts. The mathematics classroom should not expect a blind application of algorithms but should rather encourage students to find many different ways to solve problems.

As per the National Education Policy (NEP) 2020, computational thinking has also been gently introduced through puzzles, games, and interactive exercises that encourage students on these aspects. Indian rootedness has also been kept in mind while giving contexts for different concepts. The contributions of Indian mathematicians have also been given as part of a problem-solving approach to make students aware of India's rich mathematical heritage and its global contributions to mathematics.

The concepts and problems in this textbook are related to daily life situations. An attempt has been made to use contexts and materials that students are familiar with. Learning material sheets have been given at the back of the book that may be photocopied and used in the classroom. Exercises or activities are often given to encourage peer group efforts and discussions. However, this textbook intends to address the learning needs of a diverse group of students in the classroom.

We have tried to link concepts learnt in initial chapters with ideas in subsequent chapters, to show the connectedness and unity of mathematics. We hope that teachers can revise these concepts in a spiralling way so that students are able to appreciate the entire conceptual structure of mathematics. We hope that teachers may focus more on the ideas of squares and cubes, exponents, evolution of numbers and other notions that are new to the students, and are foundational for further learning.

Finally, this textbook aims to be more than just a textbook—it is a passport to a world of mathematical discovery and exploration. Whether used in the classroom or at home, we hope that it inspires students to embark on their own mathematical adventures, empowering them to see the beauty and relevance of Mathematics in everything. With its engaging approach and comprehensive coverage

of Grade 8 mathematics concepts, this textbook aims to captivate young minds and set them on a lifelong journey mathematical discovery.

I once again thank all the writers of and contributors of this textbook for their valuable contributions and service to the nation's mathematics teachers, learners and enthusiasts.

We look forward to your comments and suggestions regarding the textbook and hope that you will send interesting exercises, activities and tasks that you may develop while teaching and learning for future editions.

Ashutosh Wazalwar
Professor and Academic Convener
Department of Education in
Science and Mathematics
National Council of Educational
Research and Training

NATIONAL SYLLABUS AND TEACHING LEARNING MATERIAL COMMITTEE (NSTC)

1. M.C. Pant, *Chancellor*, National Institute of Educational Planning and Administration (NIEPA) (**Chairperson**)
2. Manjul Bhargava, *Professor*, Princeton University (**Co-Chairperson**)
3. Sudha Murty, Acclaimed Writer and Educationist
4. Bibek Debroy, *Chairperson*, Economic Advisory Council to the Prime Minister (EAC – PM)
5. Shekhar Mande, Former *Director General*, CSIR; *Distinguished Professor*, Savitribai Phule Pune University, Pune
6. Sujatha Ramdorai, *Professor*, University of British Columbia, Canada
7. Shankar Mahadevan, Music Maestro, Mumbai
8. U. Vimal Kumar, *Director*, Prakash Padukone Badminton Academy, Bengaluru
9. Michel Danino, Visiting Professor, IIT – Gandhinagar
10. Surina Rajan, *IAS (Retd.)*, Haryana; Former *Director General*, HIPA
11. Chamu Krishna Shastri, *Chairperson*, Bharatiya Bhasha Samiti, Ministry of Education
12. Sanjeev Sanyal, Member, Economic Advisory Council to the Prime Minister (EAC – PM)
13. M.D. Srinivas, *Chairperson*, Centre for Policy Studies, Chennai
14. Gajanan Londhe, *Head*, Programme Office
15. Rabin Chhetri, *Director*, SCERT, Sikkim
16. Pratyusa Kumar Mandal, *Professor*, Department of Education in Social Sciences, NCERT, New Delhi
17. Dinesh Kumar, *Professor*, Department of Education in Science and Mathematics, NCERT, New Delhi
18. Kirti Kapur, *Professor*, Department of Education in Languages, NCERT, New Delhi
19. Ranjana Arora, *Professor* and *Head*, Department of Curriculum Studies and Development, NCERT (**Member-Secretary**)

TEXTBOOK DEVELOPMENT TEAM

Members

Aaloka Kanhere, *Project Scientific Officer*, Homi Bhabha Centre for Science Education, Mumbai

Amartya Kumar Dutta, *Professor*, Statistics and Mathematics Unit, Indian Statistical Institute (ISI), Kolkata

Amritanshu Prasad, *Professor*, Institute of Mathematical Sciences (IMSc), Chennai

Anjali Gupte, *Principal (Retd.)*, Vidya Bhavan Public School, Udaipur, Rajasthan.

Aparna Lalingkar, *Director*, Aksharbrahma Consultancy, Pune

Ashutosh Kedarnath Wazalwar, *Professor*, Department of Education in Science and Mathematics, NCERT, New Delhi — CAG (Mathematics)
(Member Coordinator)

Geetanjali Phatak, *Head*, Department of Mathematics, S. P. College, Pune

H. S. Sharada, *Assistant Mistress*, Government High School, M. C. Thalalu, Mysore, Karnataka

Ishita Mukherjee, *Senior Resource Person*, CBSE, New Delhi

Kiran Barve, *Faculty*, Bhaskaracharya Pratisthan, Pune

K. V. Subramanyam, *Professor*, Chennai Mathematical Institute, Chennai

Madhavan Mukund, *Director*, Chennai Mathematical Institute, Chennai —
CAG Chairperson (Mathematics)

Manjul Bhargava, *Professor*, Princeton University; and **Co-Chairperson**, NSTC

Nagesh Mone, *Principal (Retd.)*, Deccan Education Society's Dravid High School, Wai, Maharashtra

Padmapriya Shirali, *Principal (Retd.)*, Sahyadri School, Pune

Patanjali Sharma, *Assistant Professor*, RIE, Ajmer, NCERT, New Delhi

Rakhi Bannerjee, *Professor*, Azim Premji University, Bengaluru

Ramchandar Krishnamurthy, *Principal*, Azim Premji School, Bengaluru

R. Ramanujam, *Visiting Professor*, APU, Bengaluru and *Professor (Retd.)*, IMSc, Chennai

Ravi Subramaniam, *Professor (Retd.)*, HBCSE, Mumbai

Shivkumar K. M., *Senior Consultant*, Programme Office, NSTC

Shravan S. K., *Senior Consultant*, Programme Office, NSTC

Sujatha Ramdorai, *Professor*, University of British Columbia, Canada and Member, NSTC

S. Vishwanath, *Professor*, IMSc, Chennai

Vijay Ravikumar, *Assistant Professor*, Azim Premji University, Bengaluru

Vijayan K., *Professor*, Department of Curriculum Studies and Development, NCERT, New Delhi

V. M. Sholapurkar, *Professor*, Bhaskaracharya Pratisthan, Pune

ACKNOWLEDGEMENTS

The National Council of Educational Research and Training (NCERT) acknowledges the guidance and support of the esteemed Chairperson and members of the Curricular Area Group (CAG): Mathematics, and other concerned CAGs for their guidelines on cross-cutting themes in developing this textbook. During the development of this textbook, various workshops were organised and subject experts from different institutions were invited. The NCERT acknowledges the valuable views and inputs given by subject experts—Manjunath Krishnapur, *Associate Professor*, Indian Institute of Science; Ashwin Guha, *Freelance Maths Educator*, Bengaluru; Gowri Satya, *Maths Educator*, Seed2Sapling Education; Jonaki Ghosh, *Professor*, Lady Shri Ram College, Delhi; Sangeeta Solanki, *TGT Mathematics*, The Heritage School, Delhi; Rishikesh Kumar, *Assistant Professor*, DESM, NCERT, New Delhi.

The Council acknowledges the efforts of Aman Bhargava, *Data Visualisation Developer*, for creating graphs based on the ‘Time Use Survey 2024’; and Arkaprovo Das, *Cartographer*, for making a map.

Acknowledgements are due for the academic and administrative support of Sunita Farkya, *Professor and Head*, DESM, NCERT, New Delhi.

For the chapter ‘Exploring Some Geometric Themes’, we borrowed extensively from the document *Geometry and the Imagination* by John Conway, Peter Doyle, Jone Gulman and Bill Thurston, for the material on visualising solids. We have also used ideas from the book *The Heart of Mathematics: An Invitation to Effective Thinking* by Edward Burger and Michael Starbird for the material on finding shortest paths on cuboids. The comic in the ‘Fractions in Disguise’ chapter is adapted from xkcd.com/1102.

The Council appreciates the contributions of Sushmita Joshi, *Senior Research Associate*; Nazrana Khan, *Senior Research Associate*; Manvendra Pratap Singh Rathour, *Junior Project Fellow*, Department of Education in Science and Mathematics, NCERT, for providing support in the development of the textbook. The NCERT acknowledges the contributions of Kishore Singhal, *DTP Operator* (contractual), Publication Division, and Abhilash Shukla, *DTP Operator*, DESM, NCERT, for all their efforts.

The Council acknowledges the efforts of Ilma Nasir, *Editor* (contractual); Aastha Sharma, *Editorial Assistant* (contractual); Adiba Tasneem, Ariba Usman, Jatinder Kumar, Praveen Kumar and Talha Faisal Khan, *Proofreaders* (contractual), Publication Division, NCERT. The Council also appreciates the efforts of Pawan Kumar Barriar, *In charge*, DTP Cell; Mohan Singh, Vipran Kumar Sharma, Bittu Kumar Mahto and Vivek Rajpoot, *DTP Operators* (contractual), Publication Division, NCERT, for all their efforts.

NOTE TO THE TEACHER

We hope that this textbook, *Ganita Prakash*, Grade 8 (Part-II), will serve as a strong support and guide to you in achieving the exciting task that you have before you—that of passing on the joy of learning the beautiful subject of Mathematics to the next generation.



This task calls for providing a fertile environment that allows for the flowering of mathematical thinking in the minds of students. Classrooms, where students just listen and write down whatever is being told to them or written on the board, are deficient in the conditions required for learning mathematics. Instead, classrooms need to be places where students are engaged in playing with mathematical concepts, finding and discussing patterns, and developing creative strategies together to solve problems. Students should also be posing problems to each other and discussing possible solutions with each other. In fact, these are the very conditions that have led to the development of the entire field of mathematics so far, and so one cannot expect students to pick up mathematical thinking and understanding without these conditions.

Fortunately, it is not difficult to create such conditions in the classroom. It just requires an interesting question, problem, pattern, or challenge to be thrown open to the students on a regular basis, and sufficient time to be given to them to play with, discuss, and work on it as a class or in pairs or groups.

Along with it, an environment that accepts mistakes and acknowledges their importance in learning needs to be nurtured.

While creating the spark for initiating mathematical thinking in classrooms is not difficult, sustaining it may be challenging and may involve efforts from your side. Nevertheless, even if just the first part of throwing open a question, problem, pattern, or challenge is done at least once or twice a week, accompanied by sufficient waiting time from your side for students to play, discuss, and work on it, it can have a great positive impact on how the students view and approach mathematics.

It should be noted that this positive impact will not happen overnight. This takes time and depends on various factors, such as the number of opportunities you give for problem-solving, your patience, and the encouragement you give to the students.

To support you in posing problems, all the problems or questions in this book are marked using the icons  and . These icons are indicators of potential opportunities to start off a process of problem-solving and exploration in the classroom. You will find some

of the problems labelled . Such questions can especially be made as topics for classroom discussion.

An owl mascot appears at various points in the textbook to

highlight important mathematical processes, ways of thinking, and problem-solving approaches. These can be brought out during classroom discussions, both where the owl is present and also in other similar situations.

In this grade, justification/proofs of mathematical statements find an increased presence. Students should be gently encouraged to deduce properties and not be forced to do it. Whenever students face challenges in doing it, encourage them to experiment and observe, and use their intuition in figuring out properties. Providing justification/proof is a skill that takes time to develop.

To develop students' mathematical thinking and understanding of concepts, a sufficient number of problems are given. Trying to 'cover' all of them must not happen at the cost of students not getting to spend quality time on playing with and discussing them.

It is important to understand that the exploratory problems are not only for promoting problem-solving skills; they also serve in strengthening procedural fluency when children start engaging in exploration.

Efforts must be made in making students independent learners. One essential aspect required for this is an ability to read and understand mathematical text. To promote this skill, students should be encouraged to read the book by themselves and in groups. Give opportunities for them to interpret what they read and express it to others. This will also address the big problem that students face in speaking mathematics and interpreting word problems.

This textbook contains a number of open-ended problems. It also contains new treatments of certain concepts. If you are not able to solve them or follow some of them immediately, it is perfectly okay! Not everyone knows everything. Along with trying to understand and reflect upon such content, it will be very useful to take it to the classroom and open it up for discussion. After the discussion, things that are clear and those that are not yet clear can be clearly summarised. This process itself can throw a lot of light on the content.

In these discussions, you can participate as a fellow seeker, and when students see a teacher seek and think to understand something, it sets a wonderful example for them.

It is hoped that you and your students will have a great and fruitful time using this textbook!

Summary of Key Points

Time for Exploration

1. It is important to routinely pose new problems, questions, patterns, or challenges to the students and give them sufficient time to play with, discuss, and work on them, individually and in groups.
2. During this time, an environment that accepts mistakes and acknowledges their importance in learning needs to be nurtured.
3. There should be a culture where students pose problems to each other and discuss with each other various ways to approach the problems.

About the Problems in the Book

1. The exploratory problems in the textbook not only promote problem-solving; they also aim to strengthen procedural fluency when students start engaging in exploration.
2. Trying to ‘cover’ all the problems in the book must not happen at the cost of students not getting to spend quality time on playing with, discussing, and solving them.

Reading

1. Encourage students to read the textbook by themselves and in groups.
2. Give opportunities to them to interpret what they read and to express it to others.

Right of Not Knowing!

1. It is perfectly okay if some of the content is not understood immediately. Along with trying to understand and reflect upon such content, it can also be taken to the classroom and open it up for discussion. After the discussion, things that are clear and those that are not yet clear can be clearly summarised. In these discussions, you can participate as a fellow seeker, and when students see a teacher seek and think to understand something, it sets a wonderful example for them!
2. Learning is a continual process. Indeed, there is so much in mathematics that is still not known and requires further exploration!

A NOTE TO STUDENTS!

To be able to appreciate the art of mathematics, it is not enough to just be a passive spectator. You need to immerse yourself in its process like a detective getting into action to solve a mystery.



This is especially required when you see a new question or when a question arises from your own sense of wonder, or when you come across a new beautiful pattern. When you encounter these, pause your reading, and use your creativity to work out the question or understand and appreciate the pattern.

You will find that some questions are accompanied by their answers. Even if this is the case, it is worthwhile to work on the problems by yourself or in a group before you see the answer.

This will enrich your experience of going through the book!

Whenever there are questions coming up, you will see the icon  and . This indicates that it is time for figuring things out!

 indicates a main question and  indicates a sub-question.

The icons for owls  and  suggest some important processes in the learning of mathematics.

Sometimes you will find many questions collected together in a single place under the title '**Figure it Out**'.

Some questions are marked . These questions are meant to be discussed and worked out with your peers.

Finally, there are questions marked . These questions demand more creativity to be answered, and therefore will also often be more fun to answer as a result!

CONTENTS

<i>Foreword</i>	iii
<i>About the Book</i>	v
<i>Note to the Teacher</i>	xi
<i>A Note to Students</i>	xiv
Chapter 1 Fractions in Disguise	1
Chapter 2 The Baudhayana-Pythagoras Theorem	33
Chapter 3 Proportional Reasoning-2	55
Chapter 4 Exploring Some Geometric Themes	70
Chapter 5 Tales by Dots and Lines	103
Chapter 6 Algebra Play	135
Chapter 7 Area	148
<i>Learning Material Sheets</i>	

THE CONSTITUTION OF INDIA

PREAMBLE

WE, THE PEOPLE OF INDIA, having solemnly resolved to constitute India into a ¹**[SOVEREIGN SOCIALIST SECULAR DEMOCRATIC REPUBLIC]** and to secure to all its citizens :

JUSTICE, social, economic and political;

LIBERTY of thought, expression, belief, faith and worship;

EQUALITY of status and of opportunity; and to promote among them all

FRATERNITY assuring the dignity of the individual and the ²[unity and integrity of the Nation];

IN OUR CONSTITUENT ASSEMBLY this twenty-sixth day of November, 1949 do **HEREBY ADOPT, ENACT AND GIVE TO OURSELVES THIS CONSTITUTION.**

1. Subs. by the Constitution (Forty-second Amendment) Act, 1976, Sec.2. for "Sovereign Democratic Republic" (w.e.f. 3.1.1977)
2. Subs. by the Constitution (Forty-second Amendment) Act, 1976, Sec.2. for "Unity of the Nation" (w.e.f. 3.1.1977)

1

FRACTIONS IN DISGUISE



1.1 Fractions as Percentages

You might have heard statements like, “Mega Sale — up to 50% off!” or “Hiya scored 83% in her board exams”.

Do you know what the symbol ‘%’ means?

This symbol is read as **per cent**.

The word ‘per cent’ is derived from the Latin phrase ‘*per centum*’, meaning ‘by the hundred’ or ‘out of hundred’.

So, 25 **per cent (25%)** means **25 out of every 100** — like 25 people out of 100, 25 rupees out of 100 rupees, or 25 marks out of 100 marks.

If we say **50% of some quantity s**, it means

$$\begin{aligned} 50\% &= 50 \times \frac{1}{100} \times s \text{ (50 times the unit fraction of s)} \\ &= \frac{50}{100} \times s = \frac{1}{2}s. \end{aligned}$$

Thus, percentages are simply **fractions where the denominator is 100**. Examples:

$$\begin{aligned} 20\% &= \frac{20}{100} = \frac{2}{10} = \frac{1}{5}, \\ 33\% &= \frac{33}{100}. \end{aligned}$$

We saw that percentages are just fractions. Given any fraction, can we express it as a percentage? Yes, let us see how.

Expressing Fractions as Percentages

- ?** **Example 1:** Surya wants to use a deep orange colour to capture the sunset. He mixes some red paint and yellow paint to make this colour. The red paint makes up $\frac{3}{4}$ of this mixture. What percentage of the colour is made with red?

$\frac{3}{4}$ is 3 out of every 4.

That is, 6 out of every 8 (equivalent fraction).

That is, 30 out of every 40.

That is, 75 out of every 100.

This means 75%.

$$\frac{3}{4} = \frac{6}{8} = \frac{30}{40} = \frac{75}{100}$$

Explaining this in a different way: To express $\frac{3}{4}$ as a percentage, we need to find its equivalent fraction with 100 as the denominator. Two ways of going ahead are shown below.

Method 1

$$\begin{aligned}\frac{3}{4} &= \frac{3 \times 25}{4 \times 25} \\ &= \frac{75}{100} = 75\%\end{aligned}$$

Method 2

$$\begin{aligned}\frac{3}{4} &= \frac{x}{100} \\ \frac{3}{4} \times 100 &= \frac{x}{100} \times 100 \\ \text{[multiply both sides by 100]} \\ x &= \frac{3}{4} \times 100 \\ &= 75.\end{aligned}$$

So, $\frac{3}{4}$ can be expressed as 75%.

Observe the following bar model diagram showing the equivalence between $\frac{3}{4}$ and 75%.

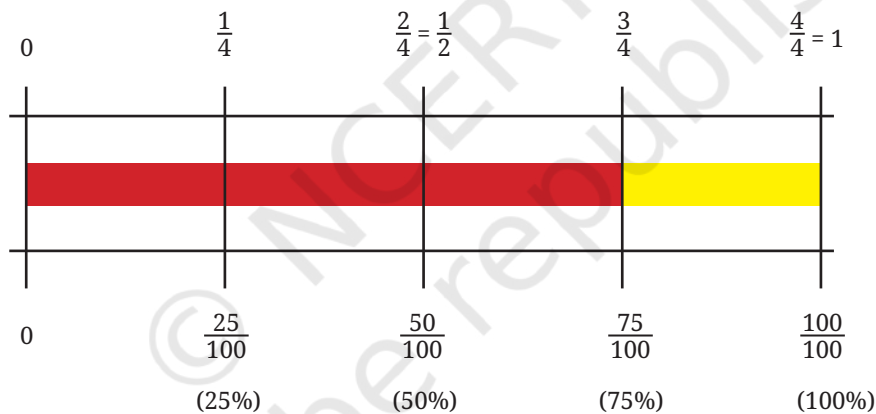

? Can you tell what percentage of the colour was made using yellow?

? **Example 2:** Surya won some prize money in a contest. He wants to save $\frac{2}{5}$ of the money to purchase a new canvas. Express this quantity as a percentage.

Try to understand the different methods for solving this problem, as shown below.

Method 1

$$\begin{aligned}\frac{2}{5} &= \frac{20}{50} = \frac{40}{100} \\ &= 40\%.\end{aligned}$$

Method 2

$$\begin{aligned}\frac{2}{5} &= \frac{x}{100} \\ x &= \frac{2}{5} \times 100 = 40.\end{aligned}$$

? Try completing Method 3 by filling the boxes.

Method 3

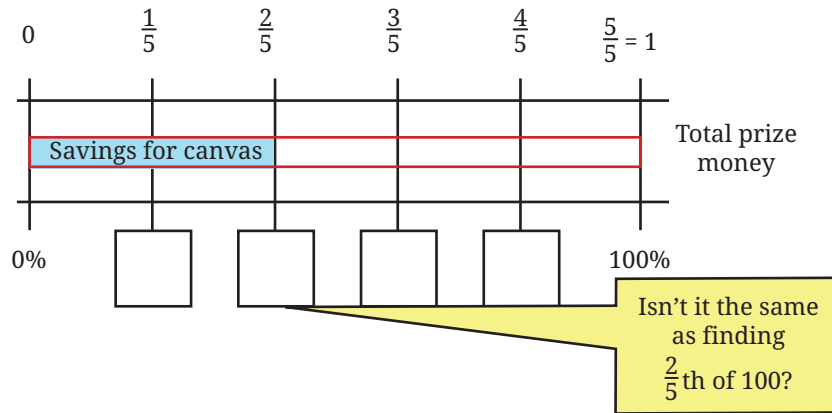

Several problems in mathematics can be approached and solved in different ways. While the method you came up with may be dear to you, it can be amusing and enriching to know how others thought about it.

A fraction is of a unit, while a percentage is per 100. Therefore, to express a fraction as a percentage, we can just multiply the fraction by 100.

? **Example 3:** Given a percentage, can you express it as a fraction? For example, express 24% as a fraction.

Since a percentage is a fraction, 24% is the same as $\frac{24}{100}$.

We can find other equivalent forms of $\frac{24}{100} = \frac{12}{50} = \frac{6}{25} = \frac{48}{200}$.

In general, we can say that a percentage, $z\%$, can be expressed by any of the fractions that are equivalent to $\frac{z}{100}$.

? **Figure it Out**

1. Express the following fractions as percentages.

- | | | |
|-----------------------|---------------------|----------------------|
| (i) $\frac{3}{5}$ | (ii) $\frac{7}{14}$ | (iii) $\frac{9}{20}$ |
| (iv) $\frac{72}{150}$ | (v) $\frac{1}{3}$ | (vi) $\frac{5}{11}$ |

2. Nandini has 25 marbles, of which 15 are white. What percentage of her marbles are white?

- | | | |
|----------|----------|--------------------|
| (i) 10% | (ii) 15% | (iii) 25% |
| (iv) 60% | (v) 40% | (vi) None of these |

- In a school, 15 of the 80 students come to school by walking. What percentage of the students come by walking?
- A group of friends is participating in a long-distance run. The positions of each of them after 15 minutes are shown in the following picture. Match (among the given options) what percentage of the race each of them has approximately completed.

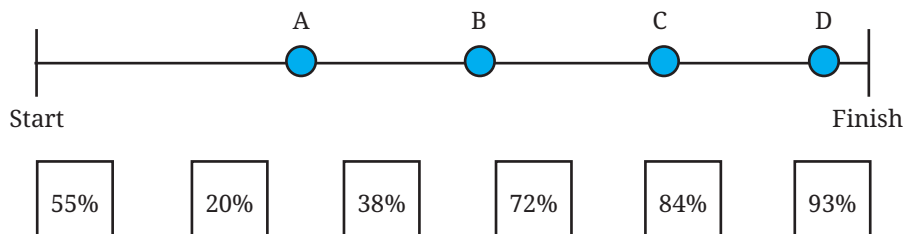

- Pairs of quantities are shown below. Identify and write appropriate symbols '>', '<', '=' in the blanks. Try to do it without calculations.
 - 50% ___ 5%
 - $\frac{5}{10}$ ___ 50%
 - $\frac{3}{11}$ ___ 61%
 - 30% ___ $\frac{1}{3}$

? Well, if percentages are just a particular type of fraction, why do we need them? Why can't we just continue using fractions?

Let us consider an example.

A biscuit-making factory is experimenting with 2 new varieties of biscuits. Sugar makes up $\frac{9}{34}$ of Variety 1 and $\frac{13}{45}$ of Variety 2. Which variety is more sugary? It may not be clear at first glance and we may have to do some calculations. But, when the same information is presented as — Sugar makes up 26.47% of Variety 1 and 28.88% of Variety 2, it is immediately clear which variety is more sugary.

If we want to have the same denominator, why choose 100 in particular? Why not 10, 50, 1000, or 43? Think.

In principle, we could choose any number as the denominator. But with 100, there are some advantages. Since our number system is base 10, numbers like 10, 100, and 1000 fit easily with decimals. For example, $31\% = \frac{31}{100} = 0.31$.

Converting between fractions, decimals, and percentages becomes quick and intuitive.

The number 100 is round, and easy to understand and work with. We could say “per 1000” or “per 100,000” (this usage is present in statistics like “per thousand people” or “per lakh”), but 100 hits the sweet spot — it's large enough to give detail, yet simple enough to grasp mentally. Per 10 would be too small for many purposes.

$$\frac{9}{34} = 26.47 \text{ percent (per 100)}$$

$$\frac{9}{34} = 2.647 \text{ per decem (per 10)}$$

$$\frac{9}{34} = 264.7 \text{ per mille (per 1000)}$$

Long before the decimal fraction was introduced, the need for it was felt in computations by tenths, twentieths, and hundredths. The idea of ‘per hundred’ can be found as early as the 4th century BCE in Kautilya’s *Arthaśhāstra*, “An interest of a *pana* and a quarter per month per cent is just. Five *panas* per month per cent is commercial interest. Ten *panas* per month per cent prevails among forests. Twenty *panas* per month per cent prevails among sea traders”.

Around the same time, the Romans used taxes of $\frac{1}{20}$, $\frac{1}{100}$ in transactions related to trade and auctions. In the Italian manuscripts of the 15th century, expressions such as ‘*xx p cento*’, ‘*x p cento*’, ‘*vii p cento*’ can be found (equivalent to our 20%, 10%, and 7%).

Percentages Around Us

Percentages are widely used in a variety of contexts. Here are some interesting findings that involve percentages.



The human body, on average, is about 60% water by weight.



Ice cream is about 30–50% air by volume.



45% of the world’s population watched at least part of the 2022 FIFA World Cup.



Over 80% of the teenagers globally fail to meet the recommendation of at least one hour of daily physical activity.

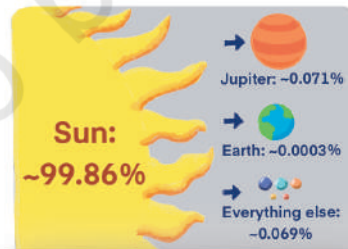

About 99.86% of the Solar System’s mass is contained in the Sun.



An estimated 52% of the agricultural land worldwide is degraded.

1.2 Percentage of Some Quantity

- Example 1:** Madhu and Madhav each ate biscuits of a different variety. Madhu's biscuits had 25% sugar, while Madhav's had 35% sugar. Can you tell who ate more sugar?



As we just saw, percentages represent fractional quantities or proportions. It would be inappropriate to compare just the percentages when they are referring to different quantities or wholes. That is, if they both had 100 g of biscuits, then clearly Madhav ate more sugar — 35 g (35% of 100 g is 35 g per 100 g) vs. Madhu's 25 g (25% of 100 g is 25 g per 100 g).

- Suppose Madhu ate 120 g of biscuits and Madhav ate 95 g of biscuits. Who consumed more sugar? Try to find out.

We know that the weight of sugar is proportional to the weight of the biscuits consumed. Madhu ate 120 g of biscuits having 25% sugar. The amount of sugar he ate is the value in the blank —

$$25 : 100 :: \underline{\quad} : 120.$$

A few ways of going forward are shown.

25% sugar means —
25 g sugar per 100 g of biscuits, which means
5 g sugar per 20 g biscuits, so
30 g sugar per 120 g biscuits.

The proportional relationship can be written as

$$\frac{25}{100} = \frac{s}{120}.$$

$$s = \frac{25}{100} \times 120 = 30.$$

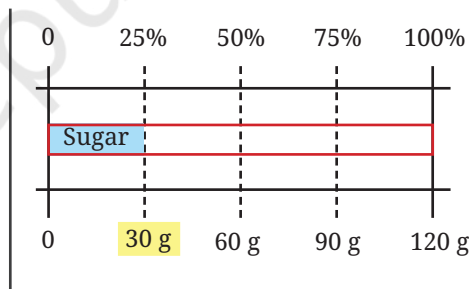

Do any of the methods match your thinking? Were you able to understand all the methods?

Now, let us find out how much sugar Madhav ate. He ate 95 g of biscuits with 35% sugar. Sometimes the numbers may not be convenient to calculate using different methods as we did just before. 100 g of the biscuits he ate has 35 g of sugar.

This means, 1 g of the biscuits has $\frac{35}{100}$ g of sugar.

We can say that 95 g of the biscuit will have $\frac{35}{100} \text{ g} \times 95 = 33.25 \text{ g}$.

This can also be solved by finding the value of s in the proportional relationship $\frac{35}{100} = \frac{s}{95}$.

Therefore, Madhav ate more sugar.

$$\frac{35}{100} = \frac{x}{1} \rightarrow x = \frac{35}{100}$$

More generally, $y\%$ of some value, say 80, is given by $\frac{y}{100} \times 80$.
 We can also say that 45% of some value, say z , is given by $\frac{45}{100} \times z$.

Free-hand Computations

We just calculated 25% of 120. Is 25% the same as $\frac{1}{4}$ th (a quarter)?

Suppose we want to find 25% of 40. Is it the same as $\frac{1}{4}$ th of 40?

Yes, since 25 is $\frac{1}{4}$ th (a quarter) of 100 ($\frac{25}{100} = \frac{1}{4}$).

Therefore 25% of 40 = $\frac{25}{100} \times 40$ is the same as $\frac{1}{4} \times 40$.

- ? Try to calculate (without using pen and paper) the indicated percentages of the values shown in the table below. Write your answers in the table.

	100	200	50	80	10	35	287
25%	25						
10%							
20%							
5%							

- ? How did you find these values? Discuss the methods with the class. Do you find anything interesting in the table?

You may have noticed that 20% of a value is double that of 10% of the same value. This will always happen as 20% (20 parts out of 100) is twice that of 10% (10 parts out of 100).

- ? Using this understanding, mentally calculate how much 40% of the values in the table above would be.

What relationship do you observe among 20% , 5% and 25% of a value?

It appears that $(20\% \text{ of } y) + (5\% \text{ of } y) = 25\% \text{ of } y$. We can verify that this property always holds:

$$\left(\frac{20}{100} \times y\right) + \left(\frac{5}{100} \times y\right) = \left(\frac{25}{100} \times y\right).$$



- ? Using this observation, mentally calculate how much 15% of the values in the table would be.
- ? Suppose you have to mentally calculate the following percentages of some value: 75%, 90%, 70%, 55%. How would you do it? Discuss.



The FDP Trio — Fractions, Decimals, and Percentages

- ? **Example 2:** We can find 50% of a value by multiplying $\frac{1}{2}$ with the value. Will multiplying the value by 0.5 also give the answer for 50% of the value?

Yes, since $\frac{1}{2} = 0.5$.

$$50\% = \frac{50}{100} = \frac{1}{2} = \frac{0.5}{1} = 0.5.$$

$$\begin{aligned} 50\% \text{ of } 24 &= 12 \\ 0.5 \times 24 &= 12 \end{aligned}$$

- ? Similarly, to find 10% of a quantity, what decimal value should be multiplied?
- ? Complete the following table:

Per cent	50%	100%	25%	75%	10%	1%	5%	43%
Fraction	$\frac{50}{100}$							
Decimal	0.5							

Activity: How Close Can You Get?

Make a pair. Each of you choose a number. Suppose, the numbers chosen are a and b . Share your numbers with each other. Both of you should estimate the percentage equivalent to the fraction $\frac{a}{b}$ (where $a < b$) and announce your answers by a fixed time, say, 5 seconds. The one whose estimate is the closest wins this round. Play this for 10 rounds.

- ? **Example 3:** The maximum marks in a test are 75. If students score 80% or above in the test, they get an A grade. How much should Zubin score at least to get an A grade?

We can find 80% of 75 in different ways, using our understanding of fraction and decimal multiplication, as well as of proportionality.

Fraction Multiplication $\rightarrow \frac{80}{100} \times 75$
 $= \frac{4}{5} \times 75 = 60.$

Decimal Multiplication $\rightarrow 0.8 \times 75 = 60.$

Proportional Reasoning \rightarrow
 Out of 100, the minimum mark is 80.
 Out of 75, it is

$$\frac{75 \times 80}{100} = 60.$$

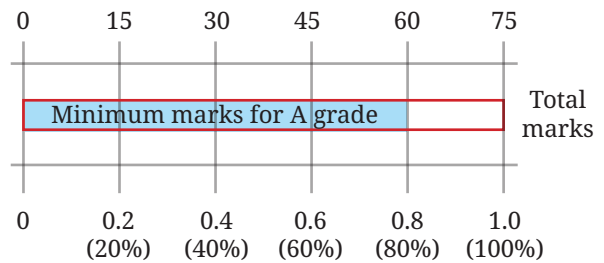

? **Example 4:** To prepare a particular millet *kanji* (porridge), suppose the ratio of millet to water to be mixed for boiling is 2:7. What percentage does the millet constitute in this mixture? If 500 ml of the mixture is to be made, how much millet should be used?

This situation can be modelled as shown in the bar model on the right side.

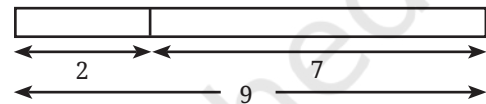

The ratio of millet to the volume of the mixture is 2:9. In other words, in one unit of the mixture, millet occupies $\frac{2}{9}$ units and water occupies $\frac{7}{9}$ units.

? Estimate first what percentage $\frac{2}{9}$ would be.

The percentage (i.e., in 100 such units) of millet in the mixture is

$$\frac{2}{9} \times 100 = 22.22\%.$$

The percentage of water in the mixture will be $100 - 22.22 = 77.78\%$.

A mixture with 22.22% millet means 100 ml mixture will have 22.22 ml millet. Therefore, 500 ml with 22.22% millet will have $5 \times 22.22 = 111.1$ ml of millet.

Half of 9 is 4.5.
 So, $\frac{2}{9}$ is clearly less than 50%. Half of 4.5 is 2.25. So, $\frac{2}{9}$ is less than 25%.

10% of 9 is 0.9.
 20% of 9 is 1.8.
 So, $\frac{2}{9}$ could be between 20% – 25%.



A given ratio can be converted to a fraction, and then to a percentage.



The practice of estimating first before calculating can improve number sense and help reduce mistakes. Often, we may not need exact values. The ability to make quick estimates is useful at these times.

Note to the Teacher: Incorporate the practice of estimating before calculating or solving as part of the problem-solving process. You may remind and encourage students as needed.

- Example 5:** A cyclist cycles from Delhi to Agra and completes 40% of the journey. If he has covered 92 km, how many more kilometres does he have to travel to reach Agra?

Let us first try to model this situation by a bar model.

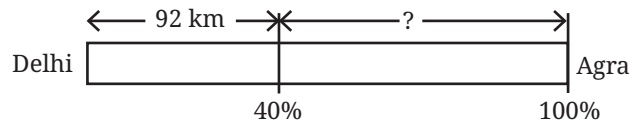

- Estimate first before solving further.

A few ways of solving this problem are shown below. Does your method match any of the given ones? Do you like any of the other methods?

It is given that 40% of the distance is 92 km. We have to find out how much the rest of the 60% distance is.

Method 1	Method 3	Method 4
<p>40% is 92 km, therefore 20% is 46 km. This makes 60% to be $92 + 46 = 138$ km.</p>	<p>$\frac{40}{100} = \frac{92}{d}$ (d is the total distance) $d = 92 \times \frac{100}{40} = 230$. Remaining distance = $230 \text{ km} - 92 \text{ km}$ $= 138 \text{ km}$.</p>	<p>If x is the remaining distance then the total distance from Delhi to Agra is $x + 92$. Since, we know that 92 is 40% of this total distance, $\frac{40}{100} \times (x + 92) = 92$. $(x + 92) = 92 \times \frac{100}{40}$ $x = 230 - 92 = 138$.</p>
<p>Method 2</p> <p>If 40% is 92, 60% is ? $40 : 92 :: 60 : ?$ $\frac{40}{92} = \frac{60}{r}$ (r is the remaining distance) $r = 60 \times \frac{92}{40} = 138$.</p>		



Drawing rough diagrams can help understand the given situation better and make it easier to think further about the problem.

Percentages Greater than 100

Till now, we saw percentages with a value 100 or less than 100. Can there be percentages with a value more than 100? What could it mean when a percentage is greater than 100? Let us explore.

- Example 6:** Kishanlal recently opened a garment shop. He aims to achieve a daily sales of at least ₹5000. The sales on the first 2 days were ₹2000 and ₹3500. What percentage of his target did he achieve?

The percentage target achieved is visualised below.

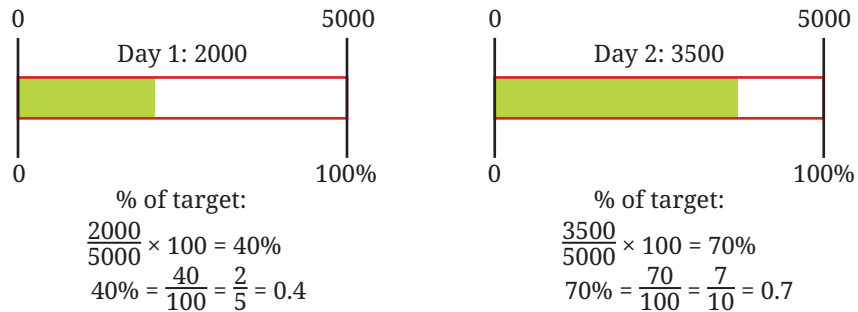

It is 40% on Day 1 and 70% on Day 2.

Another way of saying it is — he was 60% short of his target on Day 1 and 30% short of his target on Day 2.

- ? In the next two days, he made ₹5000 and ₹6000 respectively. What percentage of his target are these values?

His target is ₹5000, and he made ₹5000 on Day 3 — this is 100%. On Day 4, he made ₹6000, which is 1000 more than his target.

- ? What percentage of the target was achieved on Day 4?

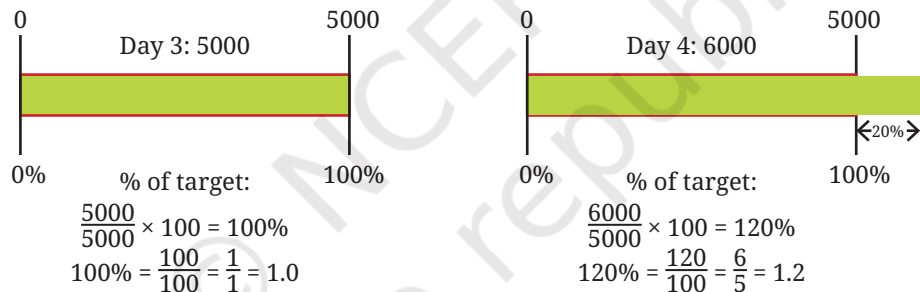

1000 is 20% of 5000. Therefore, 6000, (5000 + 1000) is 100% + 20% = 120% of 5000. It can also be computed as $\frac{6000}{5000} \times 100 = \frac{6}{5} \times 100 = 120\%$. This means he achieved 120% of his target, i.e., 20% more than his target.

- ? On Days 5 and 6 his sales were ₹7800 and ₹9550 respectively. Calculate the percentage of the target achieved on these days.

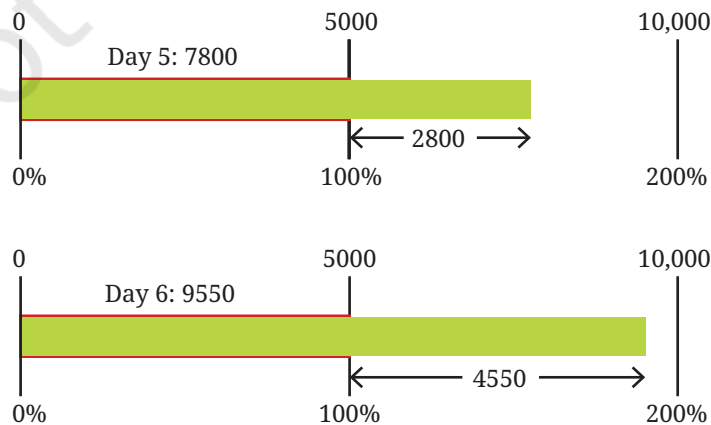

- On Day 7, he achieved 150% of his target. On Day 8, he achieved 210% of his target. Find the sales made on these days.

Suppose on some day, he made ₹2500. This can be expressed as “He achieved $\frac{1}{2}$ of his target” or “He achieved 50% of his target” or “He achieved 0.5 of his target”. On some other day, he made ₹10,000. We can say “He achieved twice/double/2 times his target” or “He achieved 200% of his target”.

- Complete the table below. Mark the approximate locations in the following diagram.

Percent	90%	110%	200%	250%	15%	173%	358%	28.9%	305%
Fraction									
Decimal									

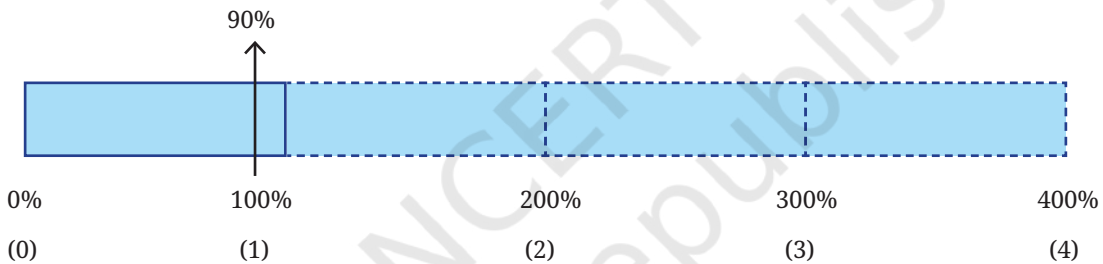

- Example 7:** A farmer harvested 260 kg of wheat last year. This year, they harvested 650 kg of wheat. What percentage of last year’s harvest is this year’s harvest?

This year’s harvest = $\frac{650}{260} \times 100 = 250\%$ of last year’s harvest.
250% indicates that it is 2.5 times the original value.

- Figure it Out**
Estimate first before making any computations to solve the following questions. Try different methods including mental computations.

1. Find the missing numbers. The first problem has been worked out.

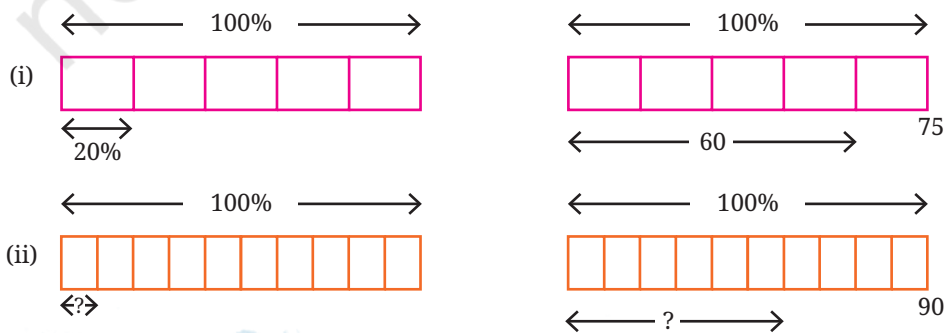

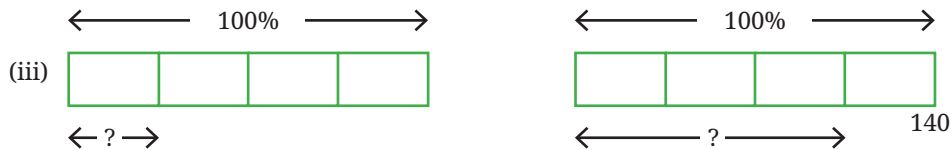

2. Find the value of the following and also draw their bar models.
- (i) 25% of 160 (ii) 16% of 250 (iii) 62% of 360
 (iv) 140% of 40 (v) 1% of 1 hour (vi) 7% of 10 kg
3. Surya made 60 ml of deep orange paint, how much red paint did he use if red paint made up $\frac{3}{4}$ of the deep orange paint?
4. Pairs of quantities are shown below. Identify and write appropriate symbols '>', '<', '=' in the boxes. Visualising or estimating can help. Compute only if necessary or for verification.
- (i) 50% of 510 50% of 515 (ii) 37% of 148 73% of 148
 (iii) 29% of 43 92% of 110 (iv) 30% of 40 40% of 50
 (v) 45% of 200 10% of 490 (vi) 30% of 80 24% of 64
5. Fill in the blanks appropriately:
- (i) 30% of k is 70, 60% of k is _____, 90% of k is _____, 120% of k is _____.
 (ii) 100% of m is 215, 10% of m is _____, 1% of m is _____, 6% of m is _____.
 (iii) 90% of n is 270, 9% of n is _____, 18% of n is _____, 100% of n is _____.
 (iv) Make 2 more such questions and challenge your peers.
6. Fill in the blanks:
- (i) 3 is _____ % of 300.
 (ii) _____ is 40% of 4.
 (iii) 40 is 80% of _____.
7. Is 10% of a day longer than 1% of a week? Create such questions and challenge your peers.
8. Mariam's farm has a peculiar bull. One day she gave the bull 2 units of fodder and the bull ate 1 unit. The next day, she gave the bull 3 units of fodder and the bull ate 2 units. The day after, she gave the bull 4 units and the bull ate 3 units. This continued, and on the 99th day she gave the bull 100 units and the bull ate 99 units. Represent these quantities as percentages. This task can be distributed among the class. What do you observe?

9. Workers in a coffee plantation take 18 days to pick coffee berries in 20% of the plantation. How many days will they take to complete the picking work for the entire plantation, assuming the rate of work stays the same? Why is this assumption necessary?
10. The badminton coach has planned the training sessions such that the ratio of warm up : play : cool down is 10% : 80% : 10%. If he wants to conduct a training of 90 minutes. How long should each activity be done?
11. An estimated 90% of the world's population lives in the Northern Hemisphere. Find the (approximate) number of people living in the Northern Hemisphere based on this year's worldwide population.
12. A recipe for the dish, *halwa*, for 4 people has the following ingredients in the given proportions — *Rava*: 40%, *Sugar*: 40%, and *Ghee*: 20%.
- If you want to make *halwa* for 8 people, what is the proportion of each of the above ingredients?
 - If the total weight of the ingredients is 2 kg, how much *rava*, *sugar* and *ghee* are present?



1.3 Using Percentages

To Compare Proportions

- ?** **Example 1:** Eesha scored 42 marks out of 50 on an English test and 70 marks out of 80 in a Science test. Since she lost only 8 marks in English but 10 marks in Science, she thinks she has done better at English. Reema does not agree! She argues that since Eesha has scored more marks in Science, she has done better at Science. Vishu thinks we cannot compare the scores because the maximum marks are different. Who do you think is correct?

If the maximum marks are the same, the comparison becomes easier, isn't it? For these kinds of comparisons, we need to convert both values to percentages.

$$\text{English score as a percentage} = \frac{42}{50} \times 100 = 84\%$$

$$\text{Science score as a percentage} = \frac{70}{80} \times 100 = 87.5\%.$$

The Science score (as a percentage) is higher than the English score (as a percentage). So, we can conclude that Eesha has scored better on the Science test.

Know Your Contents (KYC)

Example 2: Madhu and Madhav recently learnt about the importance of reading labels on processed food before purchase. They are at a shop to buy badam drink mix. They are looking at two products and wondering which has a larger share of badam. Can you figure it out? Which product uses a smaller proportion of food chemicals?



It is easier to compare the proportions of the ingredients if we convert them into percentages. For example,

DEF's sugar content as a percentage of total weight = $\frac{99}{150} \times 100 = 66\%$.

Complete this table by calculating the percentages to answer the questions:

	Sugar	Milk Solids	Badam Powder	Food Chemicals
DEF	66%			
Zacni				



Check if the percentages of each product add up to 100.

Percentage Increase or Decrease

Percentages are often used to describe the rate of change of quantities. For example,

1. Suppose the price of 1 kg tomatoes 3 years ago was ₹30, and the price now is ₹42. The increase in the price is ₹12.

$$\begin{aligned} \text{Percentage increase} &= \frac{\text{amount of increase}}{\text{original amount or base}} \times 100 \\ &= \frac{12}{30} \times 100 = 40\%. \end{aligned}$$

We say the price of tomatoes increased by 40% over the last 3 years.

2. The average footfall in this theater before COVID was 160. Now it is just 100. The decrease in the footfall is 60.

$$\begin{aligned} \text{Percentage decrease} &= \frac{\text{amount of decrease}}{\text{original amount or base}} \times 100 \\ &= \frac{60}{160} \times 100 = 37.5\%. \end{aligned}$$

We say the footfall in this theater post-COVID has decreased by 37.5%.

Example 3: Do the following two statements mean the same thing?

- (i) The population of this state in 1991 is 165% of that in 1961.
 (ii) The population of this state has increased by 65% from 1961 to 1991.
 Yes, both mean the same. Suppose p is the population of the state in 1961 and q is the population of the state in 1991.

Statement A implies,

$$q = 165\% \text{ of } p$$

$$q = \frac{165}{100} \times p = 1.65p$$

Statement B implies,

$$q = p + 65\% \text{ of } p$$

$$q = p + 0.65 \times p = 1.65p$$

In other words, the population of the state in 1991 is 1.65 times that in 1961.

Profit and Loss

You may have the experience of buying something — snacks, groceries, clothes, toys, etc. Very often, the shopkeeper quotes a price and after some bargaining the customer pays the negotiated amount and buys the item(s). We call the price quoted by the shopkeeper the **marked price** (sometimes this can be the MRP of an item). The price the customer pays after a discount is called the **selling price**. Also, the price the shopkeeper paid to purchase that item is called the **cost price**. Let us see how these labels are relative to the context through an example.

The picture below shows the journey of a sweater from the manufacturer to the customer and what the cost price (CP), the marked price (MP), and the selling price (SP) mean in each step.

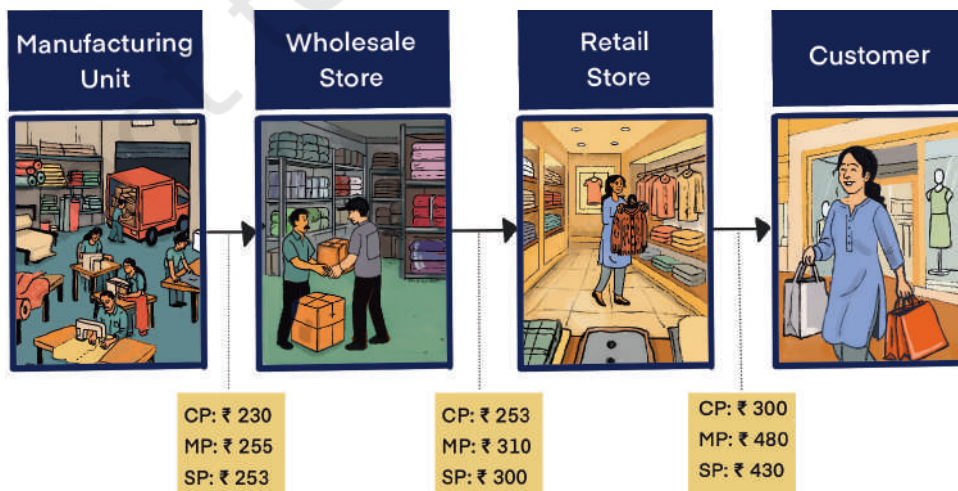

Kishanlal (retailer) buys sweaters from a wholesaler at a price of ₹300 per sweater. The marked price he quotes his customers is ₹480. After bargaining, he sells this sweater at ₹430. Notice that the selling price is greater than the cost price, resulting in a profit of ₹430 – ₹300 = ₹130. If the selling price is less than the cost price, it will result in a loss.

- ?** **Example 4:** Find out the percentage profit Kishanlal made on this sweater.

We shall consider the cost price to be 100% to find out the percentage profit made with reference to the cost price. The following rough diagram describes this situation.

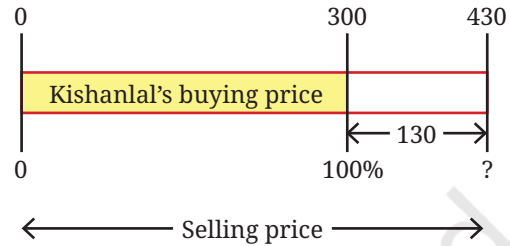

The profit amount is ₹130.

The percentage profit is $\frac{130}{300} \times 100 = 43.3\%$.

- ?** Find the profit percentage of the wholesaler and the manufacturer.
- ?** Shambhavi owns a stationery shop. She procures 200 page notebooks at ₹36 per book. She sells them with a profit margin of 20%. Find the selling price.
- ?** She sells crayon boxes at ₹50 per box with a profit margin of 25%. How much did Shambhavi buy them from the wholesaler?

- ?** **Example 5:** The rice stock in Raghu's provision store is getting old. He had purchased the rice at ₹35 per kg. To clear his stock, he sells 10 kg rice for ₹300. Find out the percentage loss.

The amount Raghu had paid towards buying the 10 kg rice is ₹350. He sold it for ₹300.

The loss is ₹350 – ₹300 = ₹50.

The percentage loss is $\frac{50}{350} \times 100 = 14.28\%$.

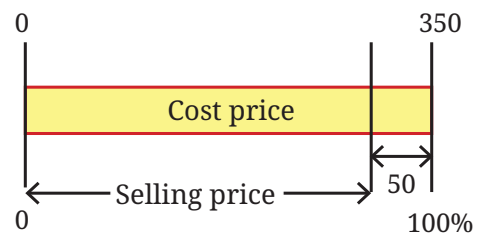

- ?** Could we have just calculated the loss percentage per kg instead? Would it be the same?
- ?** **Example 6:** Shyamala had procured decorative vases at ₹2650 per piece. One of the pieces was slightly damaged. She decides to sell it at a loss of 18%. How much will she get by selling this piece?
- ?** Try making an estimate. Draw a rough diagram depicting the given situation.

Two methods of solving this are shown.

With respect to the buying price being 100%, the selling price is 18% less than the buying price. That is, the selling price would be 82%.
 82% of $2650 = 0.82 \times 2650 = 2173$.

The loss amount is 18% of 2650.
 That is, $\frac{18}{100} \times 2650 = 477$.
 Reducing this from the buying price, $2650 - 477 = 2173$.

The sale amount of the damaged vase would be ₹2173.

- ? Due to heavy rains, Snehal could not transport strawberries to Hyderabad from his farm in Panchgani. He sells some of his stock at ₹80 per kg with a 12% loss. What is the cost price?

You have probably seen percentages mentioned when shops offer discounts! Do you know what 30% off (or 30% discount) means? It means that the shop is willing to reduce the price of the item by 30%.

- ? A utensil store is offering a 35% discount on the cooker with an MRP ₹1800. What is the selling price? If the cost price was ₹900, what is the percentage profit made after the sale?



Suppose Kishanlal achieved a sales of ₹80,000 last month. Out of this, the amount he spent on buying these goods he sold last month was ₹48,000. The difference amount, $₹80,000 - ₹48,000 = ₹32,000$, is called **gross profit**.
 After deducting the other expenses he incurred (such as transport cost, employee's salary, electricity bill, etc.) amounting to ₹8,000, the amount remaining is called **net profit**, which is $₹32,000 - ₹8,000 = ₹24,000$.
 Note: In this chapter, the term profit refers to gross profit.

Manisha sells fertiliser. She buys 50 kg bags at ₹500 per bag. She sells it at ₹750 per bag making a profit of $\frac{250}{500} \times 100 = 50\%$. Although, with respect to the ₹750 amount she has earned by selling a bag, the profit percentage is $\frac{250}{750} \times 100 = 33.33\%$.

Profit percentage is calculated based on the price the goods bought when we want to know "How much profit did I make compared to what I invested in buying the goods?".

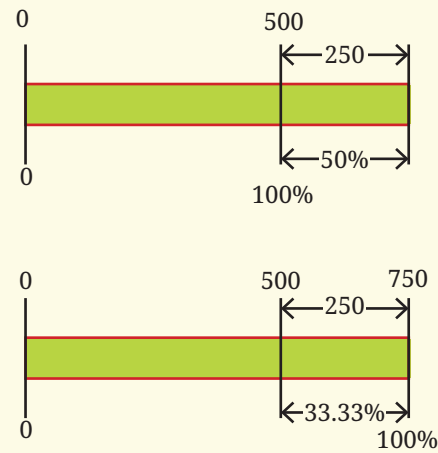

Profit percentage is calculated based on the revenue (sales amount) when we want to know “How much (net) profit did I make on my overall revenue?”.

Suppose, in a month she made sales of ₹1,50,000. The cost of buying the goods was ₹1,00,000. So, the gross profit is ₹50,000. The monthly expenses amounted to ₹5,000. The net profit is ₹45,000. Out of monthly revenue (₹1,50,000), the net profit percentage is $\frac{45000}{150000} \times 100 = \frac{3}{10} \times 100 = 30\%$.

Taxes

Tax rates, like the GST (Goods and Services Tax) rate or the Income Tax rates, are also specified as percentages. You may have noticed GST mentioned as part of bills. This means that the tax is part of the amount we pay and this amount goes to the government.

XY ELECTRICALS SALES RECEIPT			
Date:	06/07/2025		
Item	Qty.	Price.	Amount
CFL Bulb	3	₹150.00	₹450.00
Sub Total			₹450.00
CGST 9%			₹40.50
SGST 9%			₹40.50
TOTAL			₹531.00
THANK YOU			

- ❓ Check if the calculations are correct in the bill shown.
- ❓ You may share any bills you have at home with the class. Observe the different elements present in the bills. Are there any similarities or differences in these bills?



❓ Figure it Out

1. If a shopkeeper buys a geometry box for ₹75 and sells it for ₹110, what is his profit margin with respect to the cost?
2. I am a carpenter and I make chairs. The cost of materials for a chair is ₹475 and I want to have a profit margin of 50%. At what price should I sell a chair?
3. The total sales of a company (also called revenue) was ₹2.5 crore last year. They had a healthy profit margin of 25%. What was the total expenditure (costs) of the company last year?
4. A clothing shop offers a 25% discount on all shirts. If the original price of a shirt is ₹300, how much will Anwar have to pay to buy this shirt?
5. The petrol price in 2015 was ₹60 and ₹100 in 2025. What is the percentage increase in the price of petrol?

- | | | |
|-------------|----------|--------------|
| (i) 50% | (ii) 40% | (iii) 60% |
| (iv) 66.66% | (v) 140% | (vi) 160.66% |

3. Samson bought a car for ₹4,40,000 after getting a 15% discount from the car dealer. What was the original price of the car?
4. 1600 people voted in an election and the winner got 500 votes. What percent of the total votes did the winner get? Can you guess the minimum number of candidates who stood for the election?
5. The price of 1 kg of rice was ₹38 in 2024. It is ₹42 in 2025. What is the rate of inflation? (Inflation is the percentage increase in prices.)
6. A number increased by 20% becomes 90. What is the number?
7. A milkman sold two buffaloes for ₹80,000 each. On one of them, he made a profit of 5% and on the other a loss of 10%. Find his overall profit or loss.
8. The population of elephants in a national park increased by 5% in the last decade. If the population of the elephants last decade is p , the population now is
 - (i) $p \times 0.5$
 - (ii) $p \times 0.05$
 - (iii) $p \times 1.5$
 - (iv) $p \times 1.05$
 - (v) $p + 1.50$
9. Which of the following statement(s) mean the same as — “The demand for cameras has fallen by 85% in the last decade”?
 - (i) The demand now is 85% of the demand a decade ago.
 - (ii) The demand a decade ago was 85% of the demand now.
 - (iii) The demand now is 15% of the demand a decade ago.
 - (iv) The demand a decade ago was 15% of the demand now.
 - (v) The demand a decade ago was 185% of the demand now.
 - (vi) The demand now is 185% of the demand a decade ago.

Growth and Compounding

You might have come across statements like, “1 year interest for FD (Fixed Deposit) in the bank @ 6% per annum” or “Savings account with interest @ 2.5% per annum”. **Interest** is the extra money paid by institutions like banks or post offices on money deposited (kept) with them. Interest is also paid by people or institutions when they borrow money.

In a Fixed Deposit (FD), you deposit a specific amount of money for a fixed period at a predetermined interest rate. The money remains locked for the chosen duration, and the bank pays you interest on it. You cannot withdraw the amount before the maturity date without incurring a penalty. At the end of the term, you receive both your original deposit and the interest earned.

For example, a bank says that the interest rate for fixed deposits is 10% p.a. What do you understand by this statement? What is the ‘p.a.’ next to the percentage?

‘p.a.’ is the short form of per annum, which means for every year. The specified interest rate indicates that if you invest ₹6000 as a deposit for a year with the bank, they will give you ₹600 as interest on this deposit. The 10% is the **rate of interest** and the ₹6000 on which the interest is calculated is the **principal**. The amount after 1 year in your bank account will be

$$6000 + (0.10 \times 6000)$$

(principal) + (10% interest on principal)

$$= 6000 + 600 = 6600.$$

In other words, the amount deposited, ₹6000, will become 110% (or increase by 10%),

$$6000 \times 110\% = 6000 \times \frac{110}{100} = 6000 \times 1.1 = 6600.$$

This can also be expressed as

$$\text{Amount after 1 year} = \text{Principal (P)} + \text{rate of interest (r) of P}$$

Example 7: If one deposits ₹6000 in the bank, what is the amount after 3 years?

That depends on the choice of FD. There are two possibilities:

- Option 1: The interest is paid out regularly (for example, every year). The principal amount is returned after the maturity period.

		Interest returned (10% p.a.)	Amount in the FD
Year 1	Beginning		₹6000
	Ending	₹600 returned	₹6000
Year 2	Beginning		₹6000
	Ending	₹600 returned	₹6000
Year 3	Beginning		₹6000
	Ending	₹600 returned	₹6000
Total amount received		₹1800 + ₹6000 = ₹7800	

2. Option 2: The interest gained every time (say after each year) is added back to the FD, thus increasing the principal amount for the subsequent period. After the maturity period, the entire amount is returned. This phenomenon is called **compounding**.

		Interest added back (10% p.a.)	Amount in the FD
Year 1	Beginning		₹6000
	Ending	₹600 added back	₹6600
Year 2	Beginning		₹6600
	Ending	₹660 added back	₹7260
Year 3	Beginning		₹7260
	Ending	₹726 added back	₹7986
			₹7986 is returned
Total amount received		₹7986	

We can see that with compounding, the final amount is more.

- Example 8:** What percent is the total amount received with respect to the amount deposited in both the options?

This can be calculated by finding $\frac{\text{total amount received}}{\text{amount deposited}} \times 100$.

Without Compounding

$$\frac{7800}{6000} \times 100 = 130\% = 1.3.$$

In other words, the total amount received = $6000 \times (1 + 0.1 + 0.1 + 0.1)$
 $= 6000 \times 1.3.$

The percentage gain over 3 years is 30%.

With Compounding

$$\frac{7986}{6000} \times 100 = 133.1\% = 1.331.$$

In other words, the total amount received = $6000 \times 1.1 \times 1.1 \times 1.1.$
 $= 6000 \times 1.331$

The percentage gain over 3 years is 33.1%.

Figure it Out

1. Bank of Yahapur offers an interest of 10% p.a. Compare how much one gets if they deposit ₹20,000 for a period of 2 years with compounding and without compounding annually.

- Bank of Wahapur offers an interest of 5% p.a. Compare how much one gets if one deposits ₹20,000 for a period of 4 years with compounding and without compounding annually.
- Do you observe anything interesting in the solutions of the two questions above? Share and discuss.

Let us try to generalise the pattern observed in each of the options.

? **Example 9:** What is the amount we get back if we invest ₹6000 at an interest rate of 10% p.a. for 't' years?

No Compounding

Here, the interest gained every term is paid back. Therefore, the principal amount for every term shall remain the same, and as a result, the interest gained every term also shall be the same.

The interest gained in 1 term is 6000×0.1
 The interest gained in 3 terms is
 $6000 \times 0.1 \times 3$
 The total amount at the end of an FD of 3 years is
 $6000 + (6000 \times 0.1 \times 3)$.

The interest gained in 1 term is $p \times r$
 (p is the principal, r is the rate of interest in percentage)
 The interest gained in t terms is
 $p \times r \times t$
 The total amount at the end of an FD of t years is
 $p + (p \times r \times t) = p + prt$
 $= p(1 + rt)$.

With Compounding

Here, the interest gained every term/year is added back to the FD. Therefore, the principal amount increases after every term, and as a result, the interest gained every term also increases proportionately.

The total amount in the FD after Year 1 is
 $(6000) \times 1.1$
 (principal for Year 1)
 The total amount in the FD after Year 2 is
 $(6000 \times 1.1) \times 1.1$
 (principal for Year 2)
 The total amount in the FD after Year 3 is
 $(6000 \times 1.1 \times 1.1) \times 1.1$
 (principal for Year 3)
 The total amount in the FD after t years is
 $6000 \times (1.1 \times 1.1 \times 1.1 \dots \times 1.1)$
 t times
 $6000 \times (1.1)^t$.

The total amount in the FD after Year 1 is
 $(p) \times (1 + r)$
 (principal for Year 1)
 The total amount in the FD after Year 2 is
 $p \times (1 + r) \times (1 + r)$
 (principal for Year 2)
 The total amount in the FD after Year 3 is
 $p \times (1 + r) \times (1 + r) \times (1 + r)$
 (principal for Year 3)
 The total amount in the FD after t years is
 $p \times (1 + r) \times (1 + r) \times \dots \times (1 + r)$
 t times
 $p \times (1 + r)^t$.

- ② Suppose we want to know the expression/formula to find the total interest amount gained at the end of the maturity period. What would be the formula for each of the two options?



② **Figure it Out**

4. Jasmine invests amount 'p' for 4 years at an interest of 6% p.a. Which of the following expression(s) describe the total amount she will get after 4 years when compounding is not done?

- (i) $p \times 6 \times 4$ (ii) $p \times 0.6 \times 4$ (iii) $p \times \frac{0.6}{100} \times 4$
 (iv) $p \times \frac{0.06}{100} \times 4$ (v) $p \times 1.6 \times 4$ (vi) $p \times 1.06 \times 4$
 (vii) $p + (p \times 0.06 \times 4)$

5. The post office offers an interest of 7% p.a. How much interest would one get if one invests ₹50,000 for 3 years without compounding? How much more would one get if it was compounded?
6. Giridhar borrows a loan of ₹12,500 at 12% per annum for 3 years without compounding and Raghava borrows the same amount for the same time period at 10% per annum, compounded annually. Who pays more interest and by how much?
7. Consider an amount ₹1000. If this grows at 10% p.a., how long will it take to double when compounding is done vs. when compounding is not done? Is compounding an example of exponential growth and not-compounding an example of linear growth?
8. The population of a city is rising by about 3% every year. If the current population is 1.5 crore, what is the expected population after 3 years?
9. In a laboratory, the number of bacteria in a certain experiment increases at the rate of 2.5% per hour. Find the number of bacteria at the end of 2 hours if the initial count is 5,06,000.



Decline

Several items or materials lose financial value over time. Suppose someone buys a bike at your home for ₹1,00,000 and after a few years they want to sell it. The value of the bike at that time will be less than ₹1,00,000. It could depend on various factors, including how many years have passed since the purchase, how many kilometres the vehicle has been used for, if there has been any damage, or if any parts have been replaced. This is called **depreciation**—reduction of value due to use and age of the item.

- ? **Example 10:** A TV is bought at a price of ₹21,000. After 1 year, the value of the TV depreciates by 5%. Find the value of the TV after one year.

The amount of reduction in the value is 5% of 21,000 = $0.05 \times 21,000$
 $= 1050$.
 The current value is $21,000 - 1050$
 $= 19,950$.

The value of the TV after 1 year will be 95% of the current value
 $= 95\% \text{ of } 21,000 = 0.95 \times 21,000$
 $= 19,950$.

The value of the TV after 1 year will be ₹19,950.

- ? **Example 11:** The population of a village was observed to be reducing by about 10% every decade. If the current population is 1250, what is the expected population after 3 decades?

The population 1 decade later will be 0.9 times the population of the current decade.
 Therefore, the population after 1 decade will be 1250×0.9 .
 The population after 2 decades will be $1250 \times 0.9 \times 0.9$.
 The population after 3 decades will be $1250 \times 0.9 \times 0.9 \times 0.9$
 $= 911.25$.

First decade's decrease = 0.1×1250
 $= 125$.
 Population after 1 decade
 $= 1250 - 125 = 1125$.
 Second decade's decrease
 $= 0.1 \times 1125 = 112.5 \cong 112$.
 Population after 2 decades
 $= 1125 - 112 = 1013$
 Third decade's population decrease
 $= 0.1 \times 1013 = 101.3 \cong 101$.
 Population after 3 decades
 $= 1013 - 101 = 912$.

Rounding off, we can say that the expected population after 3 decades will be around 910.

Tricky Percentages

Would You Rather?

- ? You have won a contest. The organisers offer you two options to choose from:

Option A: You deposit ₹100 and you get back ₹300.

Option B: You deposit ₹1000 and you get back ₹1500.

What is the percentage gain each option gives? You can choose any option only once. Which option would you choose? Why?

Math
Talk

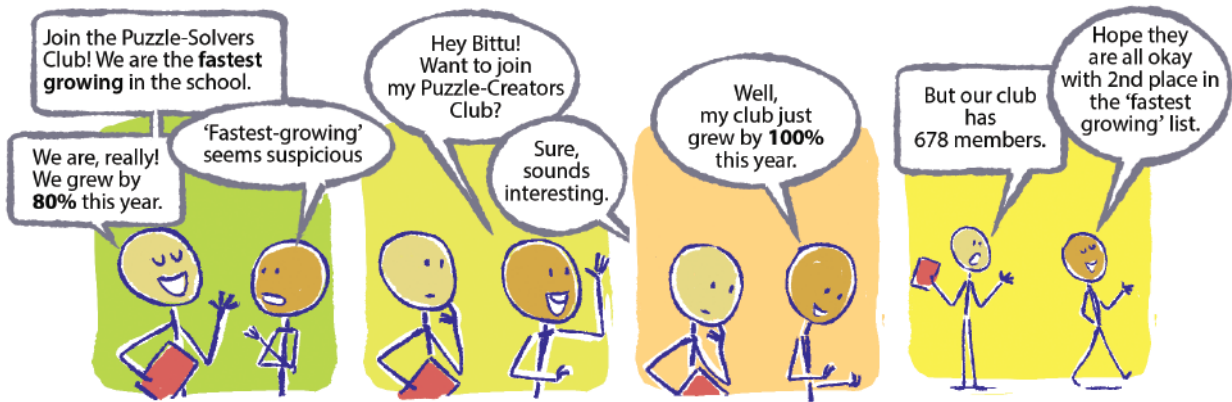

While comparing percentages, we have to be mindful that we are comparing fractions or proportions and not absolute values.

- ? A provision store is offering a stock clearance sale. Customers can choose one of the two options — 20% discount or ₹50 discount—for any purchase above ₹150. Which option would you choose if you want to:
- buy items worth ₹180
 - buy items worth ₹225
 - buy items worth ₹300

- ? **Example 12:** A bakery called Cakely is offering a 30% + 20% discount on all cakes. Another bakery called Cakify is offering a 50% discount on all cakes. Would you rather choose Cakely or Cakify if you want the cheaper cost?



It seems that both the options should give the same benefit. Although mathematically 30% + 20% is the same as 50%, the usage of 30% + 20% in shopping means compounding.

Suppose you want to buy a cake worth ₹200.

Cakely's 30% + 20% →

Applying the 30% discount → the price of cake is ₹200 – ₹60 = ₹140.

Applying the 20% discount on ₹140 → the price of cake is ₹140 – ₹28 = ₹112.

Cakify's 50% →

The 50% discount makes the price of the cake ₹100.



A Mishap

Example 13: After Surbhi bought cookware from the wholesaler, she kept a profit margin of 50% on all the products. To clear off the remaining stock, she thought she would offer a 50% discount and come out without any loss.

- Do you think she didn't make any loss?
- If she had sold goods (originally) for ₹12,000 after discount, how much loss did she incur? What is the percentage loss?
- What should have been the percentage discount offered so that she sold the goods at the price she had bought (i.e., no profit or loss)?

Let us model the situation first.

Suppose the worth of the products she bought from the wholesaler is x .

The worth corresponding to the selling price (with a 50% margin) is $1.5x$.

A 50% discount on this price will make the worth $0.75x$.

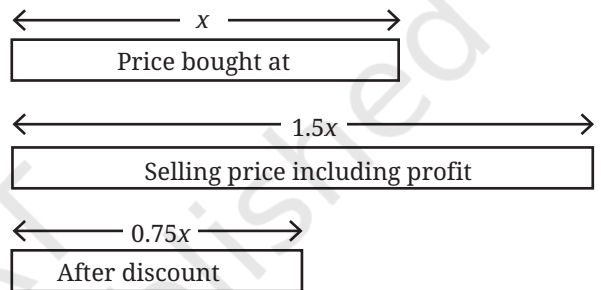

- This means the selling price is $\frac{3}{4}$ of the price the goods were bought at, i.e., a 25% loss.
- If she had sold goods worth ₹12,000,

$$0.75x = 12,000$$

$$x = 16,000.$$

She lost ₹4000.

- To sell the goods at the same price, the discount offered should be

$$1.5x - d \times (1.5x) = x$$

$$d = \frac{1}{3} = 0.33.$$

The discount offered should have been 33.33%.

? Ariba and Arun have some marbles. Ariba says, “The number of marbles with me is 120% of the marbles Arun has”. What would be an appropriate statement Arun could make comparing the number of marbles he has with Ariba’s?



? Figure it Out

- The population of Bengaluru in 2025 is about 250% of its population in 2000. If the population in 2000 was 50 lakhs, what is the population in 2025?
- The population of the world in 2025 is about 8.2 billion. The populations of some countries in 2025 are given. Match them with their approximate percentage share of the worldwide population. [Hint: Writing these numbers in the standard form and estimating can help].

Germany
83 million

India
1.46 billion

Bangladesh
175 million

USA
347 million

13%

8%

18%

10%

1%

35%

2%

2%

0.1%

- The price of a mobile phone is ₹8,250. A GST of 18% is added to the price. Which of the following gives the final price of the phone including the GST?
 - $8250 + 18$
 - $8250 + 1800$
 - $8250 + \frac{18}{100}$
 - 8250×18
 - 8250×1.18
 - $8250 + 8250 \times 0.18$
 - 1.8×8250
- The monthly percentage change in population (compared to the previous month) of mice in a lab is given: Month 1 change was +5%, Month 2 change was -2%, and Month 3 change was -3%. Which of the following statement(s) are true? The initial population is p .
 - The population after three months was $p \times 0.05 \times 0.02 \times 0.03$.
 - The population after three months was $p \times 1.05 \times 0.98 \times 0.97$.
 - The population after three months was $p + 0.05 - 0.02 - 0.03$.
 - The population after three months was p .
 - The population after three months was more than p .
 - The population after three months was less than p .
- A shopkeeper initially set the price of a product with a 35% profit margin. Due to poor sales, he decided to offer a 30% discount on the selling price. Will he make a profit or a loss? Give reasons for your answer.
- What percentage of area is occupied by the region marked 'E' in the figure?

7. What is 5% of 40? What is 40% of 5?
 What is 25% of 12? What is 12% of 25?
 What is 15% of 60? What is 60% of 15?
 What do you notice?
 Can you make a general statement and justify it using algebra, comparing $x\%$ of y and $y\%$ of x ?

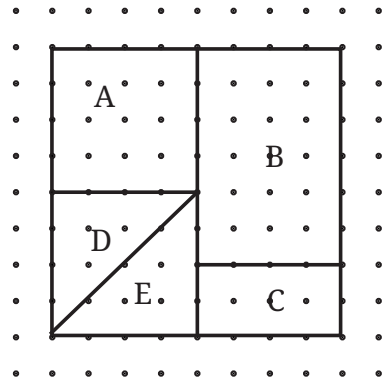

8. A school is organising an excursion for its students. 40% of them are Grade 8 students and the rest are Grade 9 students. Among these Grade 8 students, 60% are girls. [Hint: Drawing a rough diagram can help].
- What percentage of the students going to the excursion are Grade 8 girls?
 - If the total number of students going to the excursion is 160, how many of them are Grade 8 girls?

9. A shopkeeper sells pencils at a price such that the selling price of 3 pencils is equal to the cost of 5 pencils. Does he make a profit or a loss? What is his profit or loss percentage?
10. The bus fares were increased by 3% last year and by 4% this year. What is the overall percentage price increase in the last 2 years?
11. If the length of a rectangle is increased by 10% and the area is unchanged, by what percentage (exactly) does the breadth decrease by?



12. The percentage of ingredients in a 65 g chips packet is shown in the picture. Find out the weight each ingredient makes up in this packet.
13. Three shops sell the same items at the same price. The shops offer deals as follows:
 Shop A: “Buy 1 and get 1 free”
 Shop B: “Buy 2 and get 1 free”
 Shop C: “Buy 3 and get 1 free”

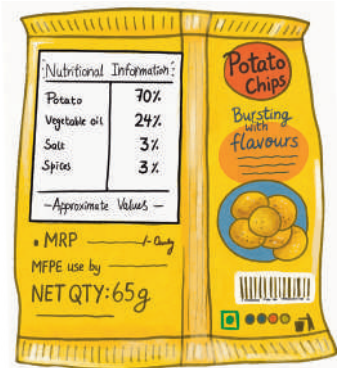

Answer the following:

- If the price of one item is ₹100, what is the effective price per item in each shop? Arrange the shops from cheapest to costliest.
- For each shop, calculate the percentage discount on the items. [Hint: Compare the free items to the total items you receive.]
- Suppose you need 4 items. Which shop would you choose? Why?

14. In a room of 100 people, 99% are left-handed. How many left-handed people have to leave the room to bring that percentage down to 98%?



15. Look at the following graph.

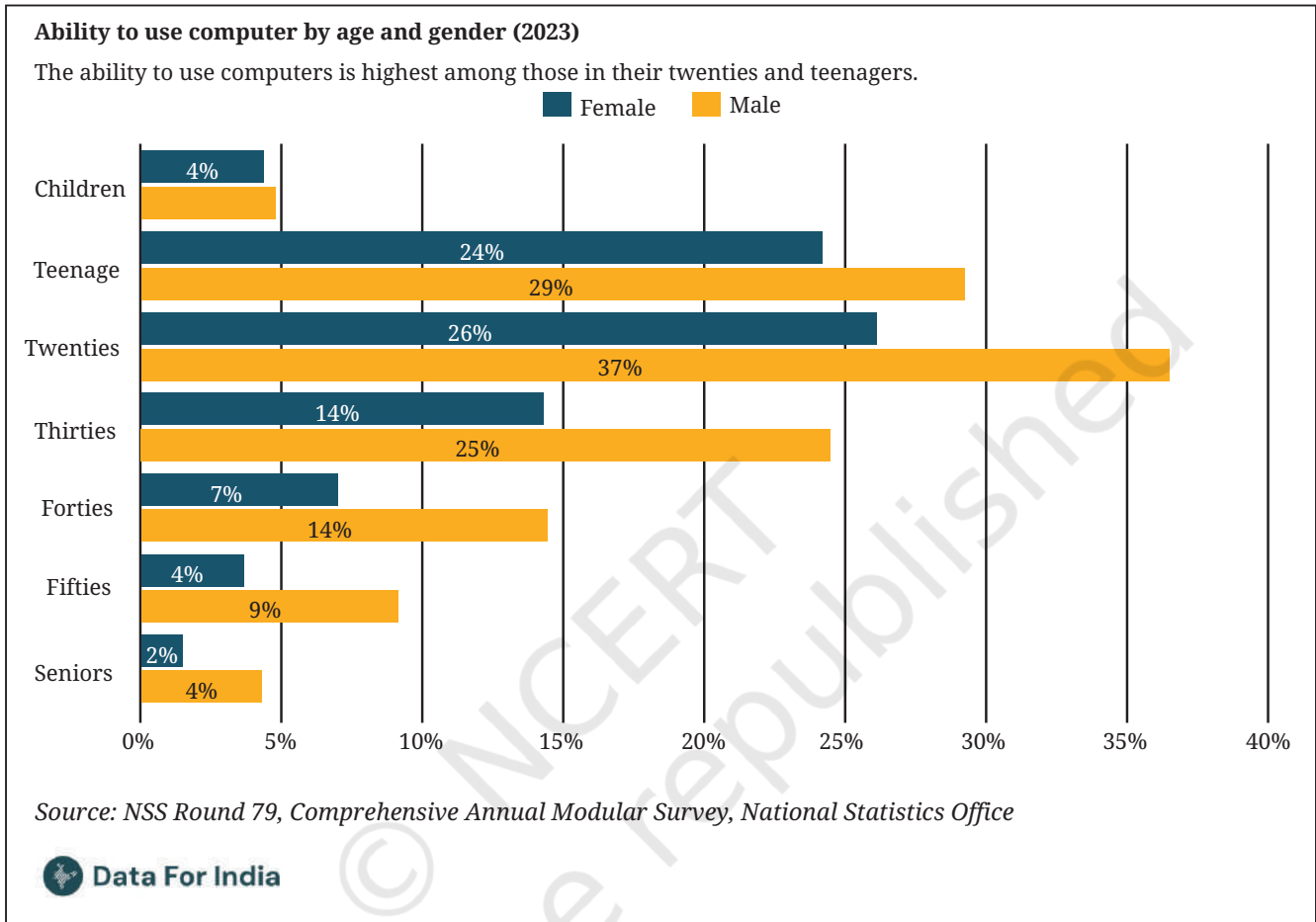

Based on the graph, which of the following statement(s) are valid?

- (i) People in their twenties are the most computer-literate among all age groups.
- (ii) Women lag behind in the ability to use computers across age groups.
- (iii) There are more people in their twenties than teenagers.
- (iv) More than a quarter of people in their thirties can use computers.
- (v) Less than 1 in 10 aged 60 and above can use computers.
- (vi) Half of the people in their twenties can use computers.

SUMMARY

- Percentages are widely used in our daily life.
- Percentages are fractions with denominator 100. Percentages are denoted using the symbol ‘%’, pronounced ‘per cent’. $x\% = \frac{x}{100}$.
- Fractions can be converted to percentages and vice versa. Decimals too can be converted to percentages and vice versa. For example, $\frac{4}{10} = 0.4 = 40\%$.
- We have learnt to find the exact number when a certain percentage of the total quantity is given.
- When parts of a quantity are given to us as ratios, we have seen how to convert them to percentages.
- The increase or decrease in a certain quantity can also be expressed as a percentage.
- The profits or losses incurred in transactions, and tax rates, can be expressed in terms of percentages.
- We have seen how a quantity or a number grows when compounded. Interest rates are a common example of compounding. If p is the principal, r is the rate of interest, and t is the number of terms, then the total amount after the maturity period is

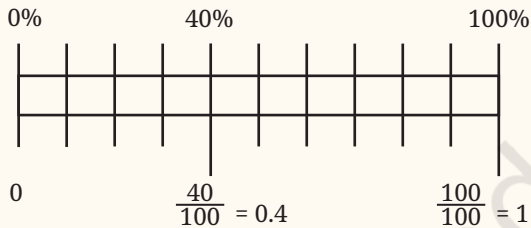

<p style="text-align: center;">Without compounding, $p(1 + rt)$ p remains the principal for all the terms.</p>	<p style="text-align: center;">With compounding, $p \times (1 + r) \times (1 + r) \times \dots \times (1 + r) = p(1 + r)^t$</p> <div style="display: flex; align-items: center;"> <div style="flex: 1;"> </div> <div style="flex: 1; font-size: small; padding-left: 10px;"> <p style="color: red;">Principal for term 1</p> <p style="color: blue;">Principal for term 2</p> <p style="color: green;">Principal for term 3</p> <p style="color: orange;">Principal for term t</p> </div> </div>
--	--

- A situation or a problem can often be solved by describing it using a rough diagram. We have learnt to estimate and do mental computations to solve problems related to percentages.



IT'S **PUZZLE TIME!**

Peaceful Knights

Place 8 knights on the chess board so that no knight attacks another. A knight moves in an 'L-shape'. It can move either (a) two steps vertically and one step horizontally, or (b) two steps horizontally and one step vertically. Possible moves of a knight are shown below.

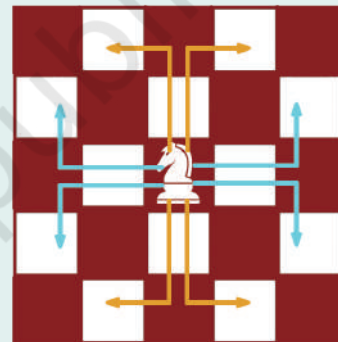
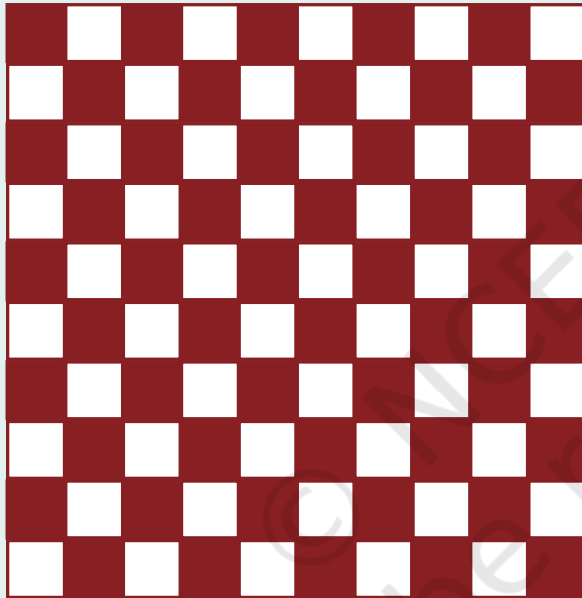

2

THE BAUDHĀYANA-PYTHAGORAS THEOREM



0889CH02

2.1 Doubling a Square

In Baudhāyana's *Śulba-Sūtra* (c. 800 BCE), Baudhāyana considers the following question:

- ? How can one construct a square having double the area of a given square?

A first guess might be to simply double the length of each side of the square. Will this new square have double the area of the original square?

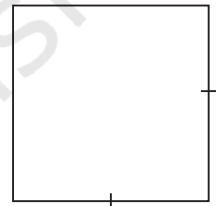

It's not hard to see that the new square will have area $2 \times 2 = 4$ times the area of the original square:

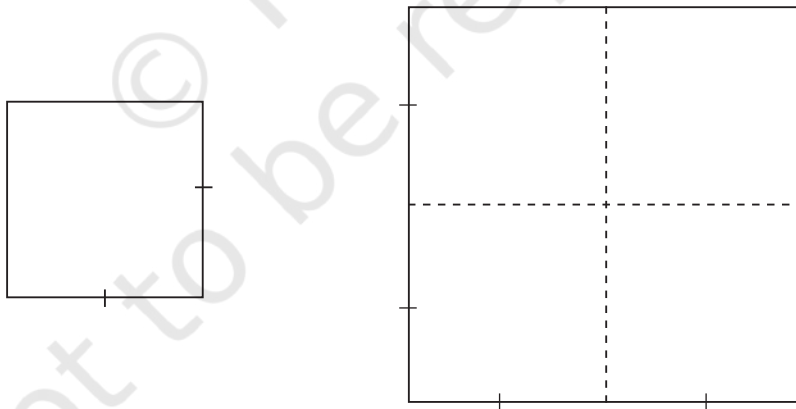

So how can one make a square that has double the area? Baudhāyana in his *Śulba-Sūtra* (Verse 1.9) gave an elegant answer to this question:

The diagonal of a square produces a square of double the area of the original square.

As Baudhāyana says, the key is to construct a square on the diagonal of the original square:

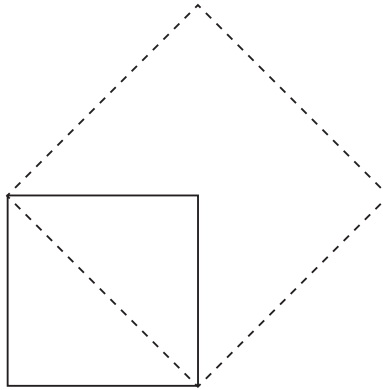

- ❓ Why does the new dotted square have double the area of the original square?

In many of the constructions in the *Śulba-Sūtra*, it is desirable to construct, where needed, what Baudhāyana calls ‘east-west’ and ‘north-south’ lines, i.e., horizontal and vertical lines that are perpendicular to each other. Can you draw some horizontal and vertical lines to see why the new square has double the area of the original square? You could draw some horizontal and vertical lines as shown on the right.

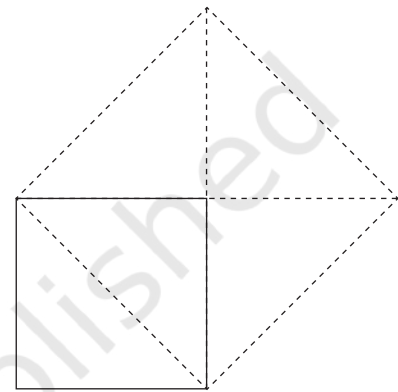

- ❓ Why should the extension of the vertical and horizontal sides of the original square pass through the vertices of the dotted square?



[**Hint:** From the diagonal property of a square, the line that bisects an angle passes through the opposite vertex. Argue why the vertical and horizontal sides of the original square bisect the two angles of the dotted square.]

So, the new square has double the area of the original square, because the original square is made up of two small triangles, while the new square is made up of four small triangles.

- ❓ Moreover, all these small triangles are congruent to each other. Can you explain why?

Adding some more horizontal and vertical lines can make the situation even clearer:

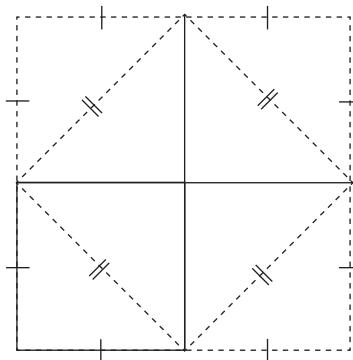

So we can make the following sequence of squares:

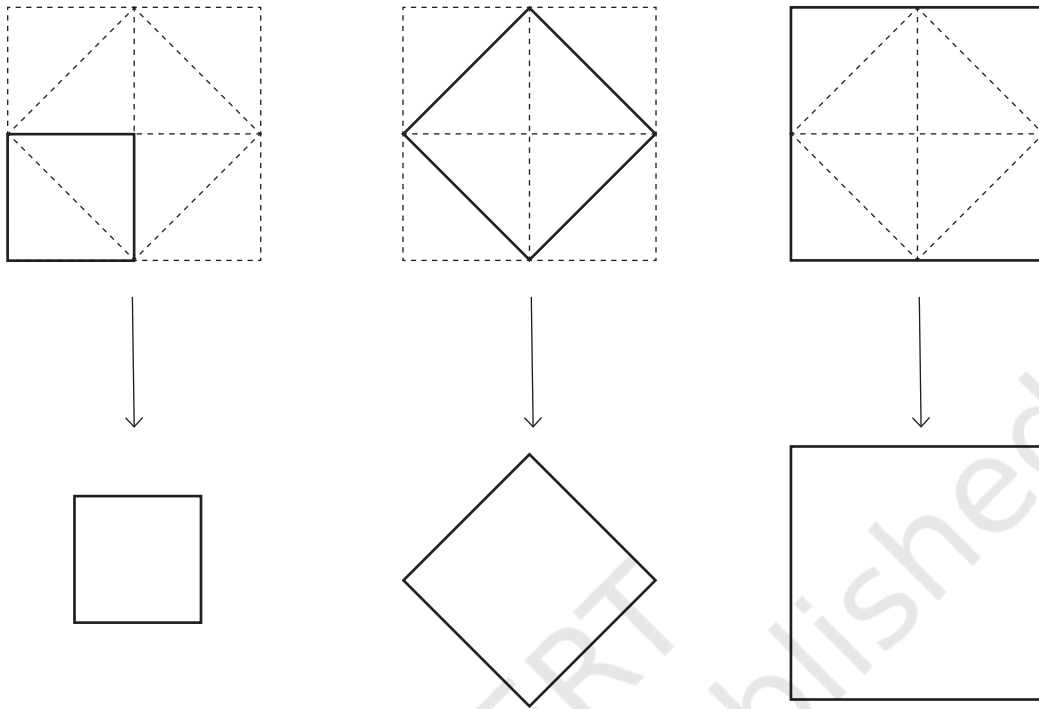

Each square has double the area of the previous one, as they are made up of 2, 4, and 8 small triangles, respectively.

Doubling a Square Using Paper

? Cut out two identical squares of paper. Draw, label, and cut as follows:

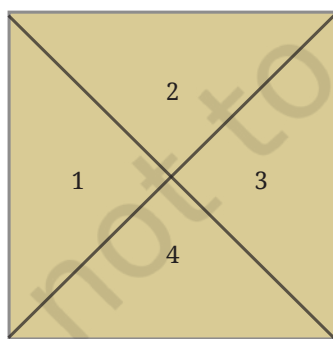

Square 1

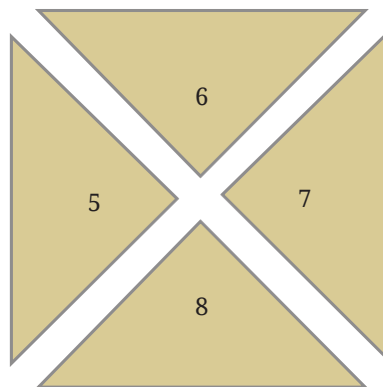

Identical Square 2

Now place the pieces 5, 6, 7, and 8 around Square 1 to get a square with double the area.

2.2 Halving a Square

- ? Now suppose we are given a square, and we want to construct a square whose area is half that of the original square. How would you do it?

One way to do it is to reverse the construction of the previous section. We draw a tilted smaller square inside the larger one:

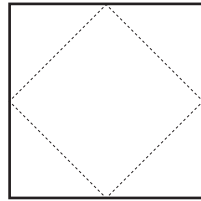
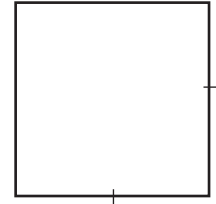

- ? Why is the smaller inside square half the area of the larger square? Again, adding some east-west and north-south lines can explain it:

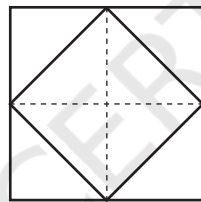

Halving a Square Using Paper

- ? Cut out a square from a piece of paper. Now make a square whose area is half the area of the first square.
- ? Will the square having half the sidelength have half the area? Why not? How many such squares will fill the original square?

Fold the square paper inward, as shown, such that the crease lines pass through the midpoints of the sides. PQRS is the required square with half the area.

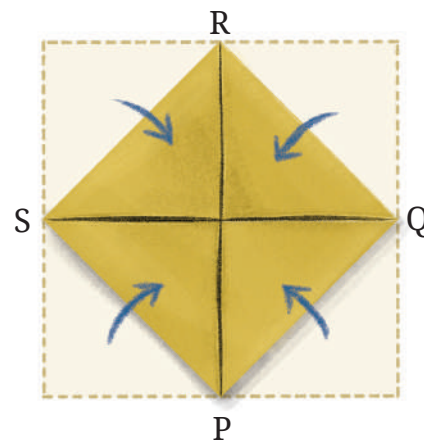

- ❓ Why is PQRS a square? Why is its area half that of the original paper?
 Explain by connecting QS and PR, finding the different angles formed, and then using triangle congruence.

2.3 Hypotenuse of an Isosceles Right Triangle

Recall that in a right triangle, the side opposite to the right angle is called the **hypotenuse**.

- ❓ Find the hypotenuse of this isosceles right triangle.

We know that a square of side 1 unit is made of two such isosceles right triangles. We also know that the square constructed on the diagonal of this square has twice the area of the original square.

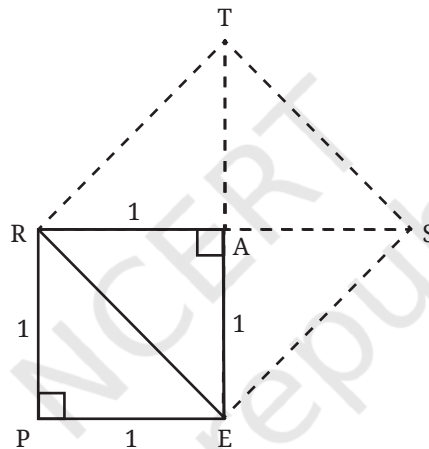
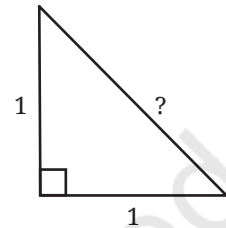

We do not yet know the length of the hypotenuse, but we know the area of the square REST on it!

$$\begin{aligned} \text{Area of REST} &= 2 \times \text{Area of PEAR} \\ &= 2 \times 1 = 2 \text{ sq. units.} \end{aligned}$$

We know the relation between the side and the area of a square. If c is the hypotenuse ER, then

$$\text{Area of REST} = c \times c = c^2.$$

$$\text{So, } c^2 = 2.$$

$$\text{Therefore, } c = \sqrt{2}.$$

Thus, the hypotenuse is of length $\sqrt{2}$ units.

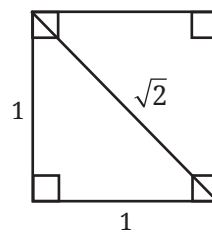
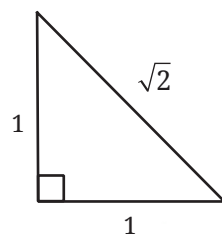

In the rest of this chapter, we will assume that all the lengths are of a fixed unit unless specified otherwise.

? What is the value of $\sqrt{2}$?

Decimal Representation of $\sqrt{2}$

The decimal representation of $\sqrt{2}$ can be found using the following argument.

? Is $\sqrt{2}$ less than or greater than 1?

A square of sidelength 1 unit has an area of 1 sq. unit. A square of sidelength $\sqrt{2}$ has an area of 2 sq. units. So, 1 is less than $\sqrt{2}$.

In other words, $1^2 = 1$, and $\sqrt{2}^2 = 2$.

Therefore, $1 < \sqrt{2}$.

? Is $\sqrt{2}$ less than or greater than 2?

A square of sidelength 2 units has an area of 4 sq. units. A square of sidelength $\sqrt{2}$ has an area of 2 sq. units. So, 2 is greater than $\sqrt{2}$.

In other words, $\sqrt{2}^2 = 2$, and $2^2 = 4$.

Therefore, $\sqrt{2} < 2$.

Thus, $1 < \sqrt{2} < 2$.

We call 1 a lower bound on $\sqrt{2}$ and 2 an upper bound.

? Can we find closer bounds for $\sqrt{2}$?

$$1.1^2 = 1.21$$

$$1.2^2 = 1.44$$

$$1.3^2 = 1.69$$

$$1.4^2 = 1.96$$

$$1.5^2 = 2.25$$

$$\text{So, } 1.4 < \sqrt{2} < 1.5$$

$$1.41^2 = 1.9881$$

$$1.42^2 = 2.0164$$

$$\text{So, } 1.41 < \sqrt{2} < 1.42$$

$$1.411^2 = 1.990921$$

$$1.412^2 = 1.993744$$

$$1.413^2 = 1.996569$$

$$1.414^2 = 1.999396$$

$$1.415^2 = 2.002225$$

$$\text{So, } 1.414 < \sqrt{2} < 1.415$$

? Will we ever get a number with a terminating decimal representation whose square is 2?

If there is such a terminating decimal starting with 1.414... whose square is 2, then it must have a non-zero last digit. If this is the case, then the decimal representation of its square will also have a non-zero last digit after the decimal point. For example, if $\sqrt{2}$ is of the form 1.414...4, then its square will be of the form—

$$\square . \square \square \square \dots \square 6$$

So a terminating decimal cannot have 2 or 2.000... as its square.

Thus, the decimal expansion of $\sqrt{2}$ must go on forever, i.e., it has a non-terminating decimal representation.

- ❓ Can $\sqrt{2}$ be expressed as a fraction $\frac{m}{n}$, where m and n are counting numbers?



If $\sqrt{2}$ could be expressed as $\frac{m}{n}$, then we would have

$$\begin{aligned}\sqrt{2} &= \frac{m}{n} \\ 2 &= \frac{m^2}{n^2} \\ 2n^2 &= m^2.\end{aligned}$$

Recall that in the prime factorization of a square number, each prime occurs an even number of times. So in the equation $2n^2 = m^2$, the prime 2 would occur an odd number of times on the left side and an even number of times on the right side. This is impossible. Thus $\sqrt{2}$ cannot be expressed as a fraction $\frac{m}{n}$.

This beautiful proof that $\sqrt{2}$ cannot be expressed as $\frac{m}{n}$ where m, n are counting numbers was given by Euclid in his book *Elements* (c. 300 BCE). We will discuss it in more detail in a later class.

Thus the number $\sqrt{2}$ cannot be expressed as a terminating decimal or a fraction. But we can think of it as a certain non-terminating decimal: $\sqrt{2} = 1.41421356...$

❓ **Figure it Out**

- Earlier, we saw a method to create a square with double the area of a given square paper. There is another method to do this in which two identical square papers are cut in the following way.

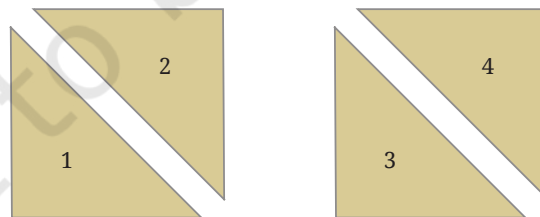

Can you arrange these pieces to create a square with double the area of either square?

- The length of the two equal sides of an isosceles right triangle is given. Find the length of the hypotenuse. Find bounds on the length of the hypotenuse such that they have at least one digit after the decimal point.

- (i) 3 (ii) 4 (iii) 6 (iv) 8 (v) 9

3. The hypotenuse of an isosceles right triangle is 10. What are its other two sidelengths? [**Hint:** Find the area of the square composed of two such right triangles.]

General Solution

The relation between the areas of a square and the square on its diagonal can be used to find a general relation between the hypotenuse and the other two sides of an isosceles right triangle.

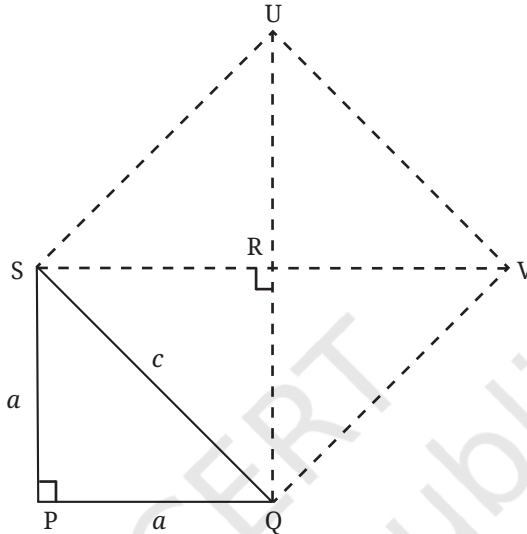

Let a be the length of the equal sides and c the length of the hypotenuse.

$$\text{Area of SQVU} = 2 \times \text{Area of PQRS}$$

$$\text{So, } c^2 = 2a^2.$$

This formula can be used to find c when a is known, or to find a when c is known.

- ?** **Example 1:** Find the hypotenuse of an isosceles right triangle whose equal sides have length 12.

We have $a = 12$. Using the formula, we get

$$c = \sqrt{2 \times 12^2} = \sqrt{288}.$$

We have $16^2 = 256$, and $17^2 = 289$.

So, $\sqrt{288}$ lies between 16 and 17.

The length of the hypotenuse of an isosceles right triangle, whose length of the equal sides is 12 units, is between 16 and 17 units.

- ?** **Example 2:** If the hypotenuse of an isosceles right triangle is $\sqrt{72}$, find its other two sides.

We have $c = \sqrt{72}$. Using the formula, we get

$$c^2 = 2a^2$$

$$\text{So, } (\sqrt{72})^2 = 2a^2$$

$$72 = 2a^2.$$

$$\text{Thus, } a^2 = \frac{72}{2} = 36.$$

$$\text{So, } a = \sqrt{36} = 6.$$

Therefore, each of the other two sides has length 6.

Use this formula to check your answers in the Figure it Out on page 39.

2.4 Combining Two Different Squares

We have seen in the previous sections how to combine two copies of the same square to make a larger square whose area is the sum of the areas of the two smaller squares.

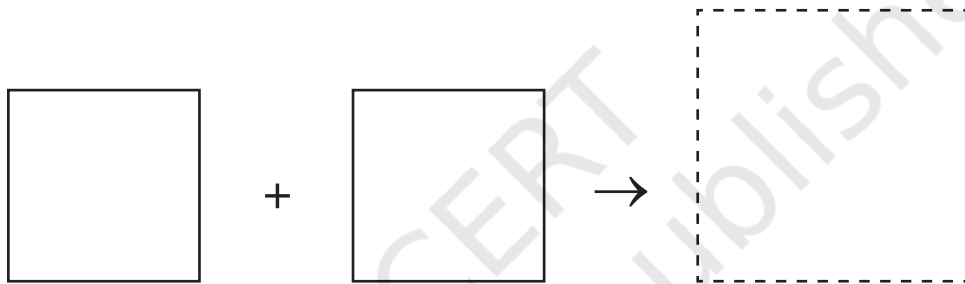

The sidelength of the larger square is the length of the diagonal of either of the smaller squares.

- ? What if we wish to combine two squares of ‘different’ sizes to make a large square whose area is the sum of the two smaller squares?



In his *Śulba-Sūtra* (Verse 1.12), Baudhāyana also gives a truly remarkable solution to this more general problem of combining two different sized squares. He writes:

The area of the square produced by the diagonal is the sum of the areas of the squares produced by the two sides.

That is, to combine two different squares, make a right-angled triangle whose perpendicular sides are the sidelengths of the two squares. The square whose sidelength is the hypotenuse of this right-angled triangle has an area that is the sum of the areas of the original two squares.

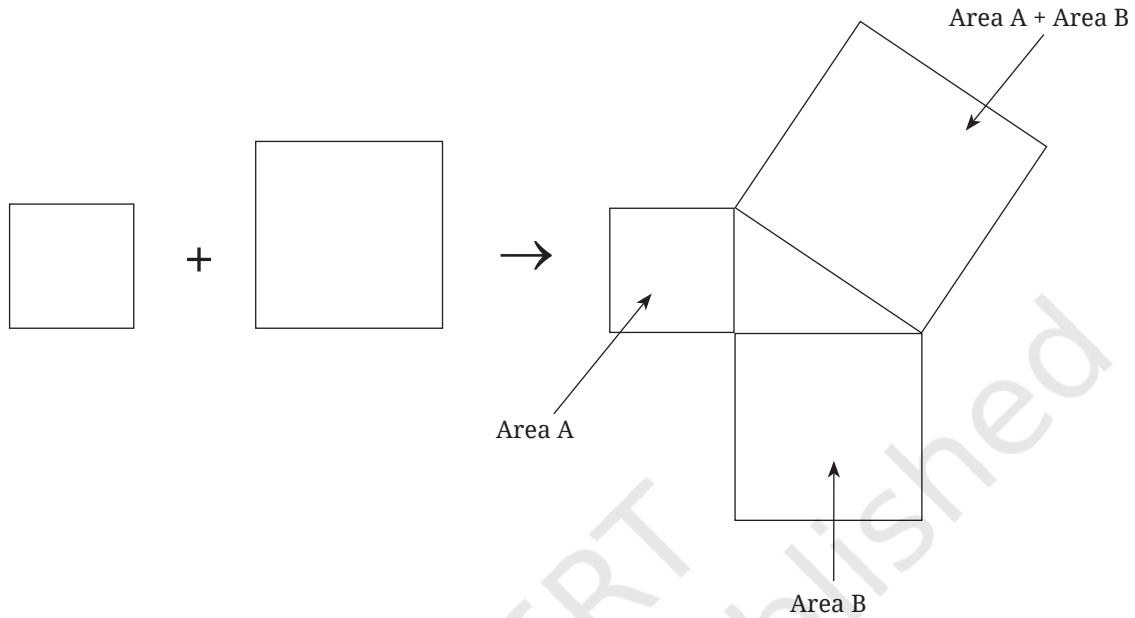

- ❓ Why does Baudhāyana's method work?
- ❓ Can you see why the method works in the case where the two squares are the same size? Does it agree with the method we used earlier to combine two same sized squares into a bigger square?

Subsequently in his *Śulba-Sūtra* (Verse 2.1), Baudhāyana provides another verse that helps in explaining why the method works in general:

To combine different squares, mark a rectangular portion of the larger square using a side of the smaller square. The diagonal of this rectangle is the side of a square that has area equal to the sum of the areas of the smaller squares.

Let us follow Baudhayan's instructions.

- Join the two squares.

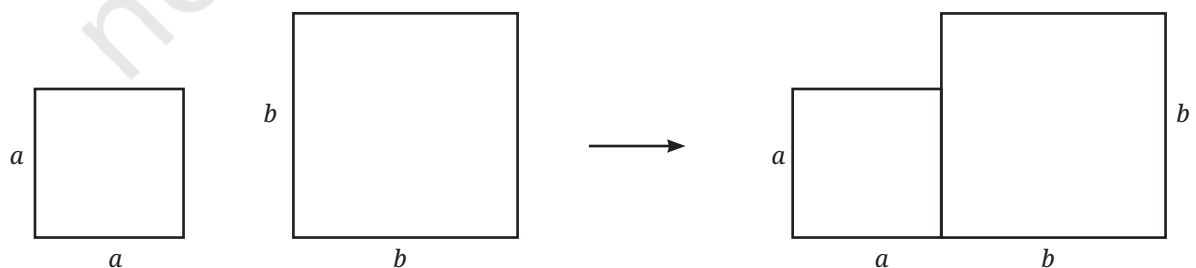

- Mark a rectangular portion of the larger square using a side of the smaller one, and draw its diagonal. By doing this, we get a right triangle with perpendicular sides a and b .

1.

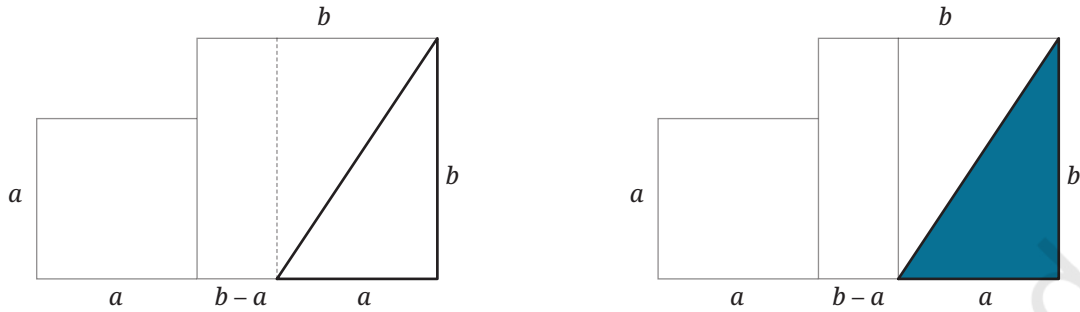

- Make a 4-sided figure over the hypotenuse by drawing three more of such right triangles:

2.

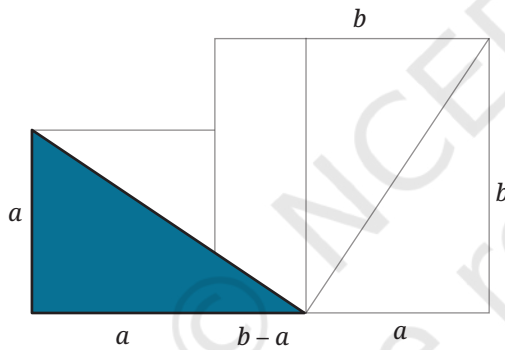

3.

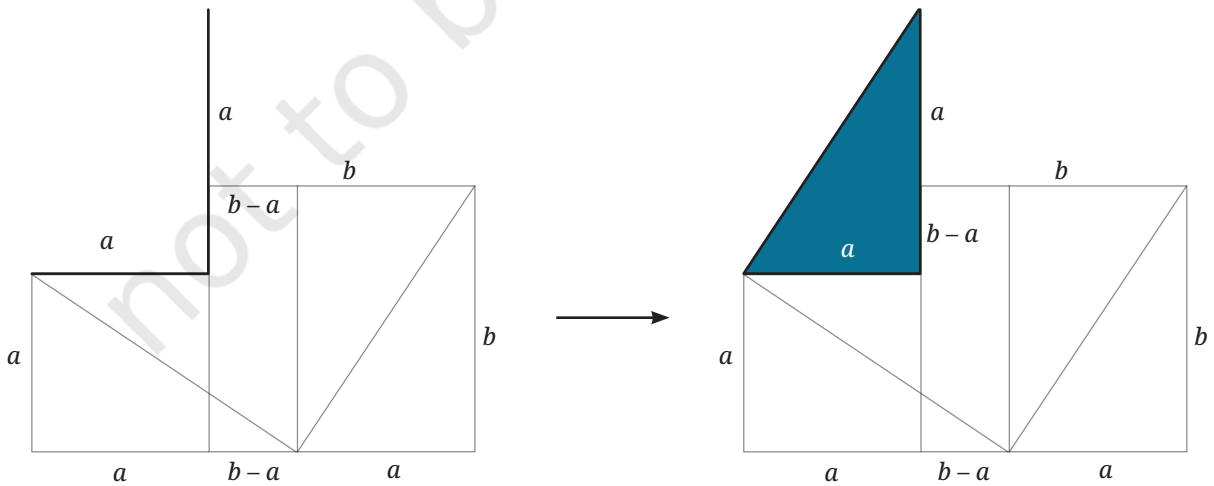

4.

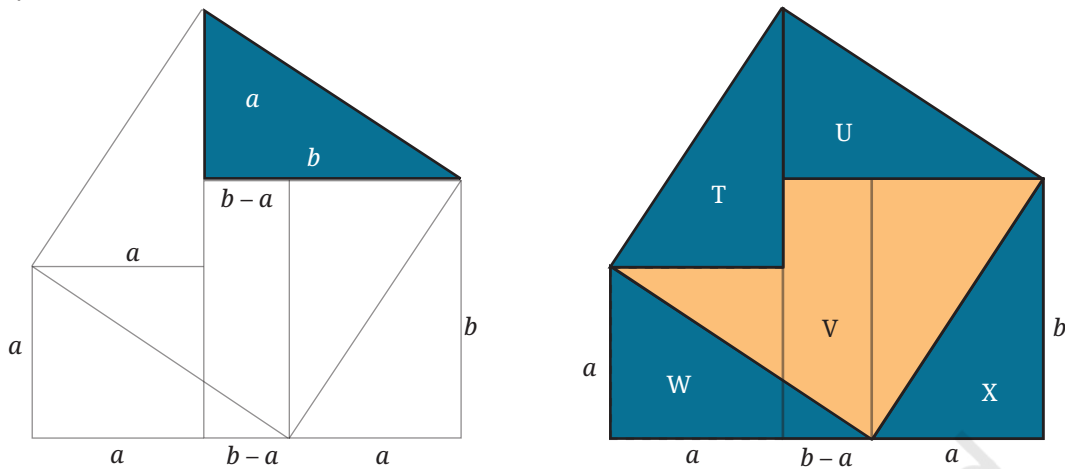

- The 4-sided figure obtained (T + U + V) is in fact a square with an area equal to the sum of the areas of the two smaller squares!

? Why?

- As T, U, X and W are all congruent, the sides of this new 4-sided figure all have the same length. Notice the angles.

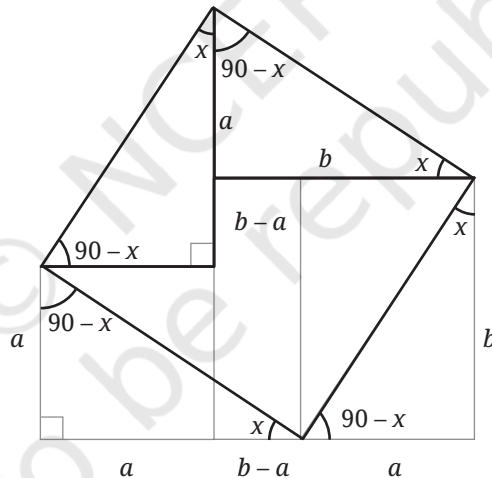

? Explain why all the angles of this new 4-sided figure are right angles and so it is a square.

Notice that this new square has as its sidelength, the hypotenuse of the right triangle of sides a and b .

- Baudhāyana's assertion is now clear:

The area of the square on the hypotenuse = the sum of the areas of T, U, and V = the sum of the areas of V, W, and X = the sum of the areas of the two given squares.

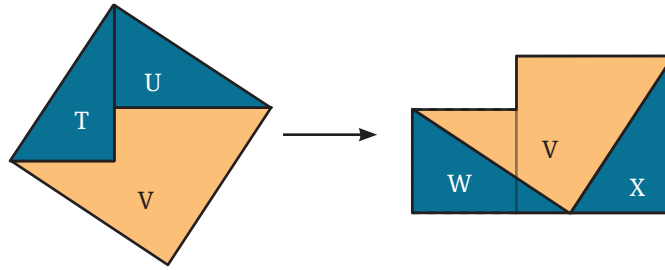

Combining Two Squares Using Paper

Cut out and join two different sized squares as follows:

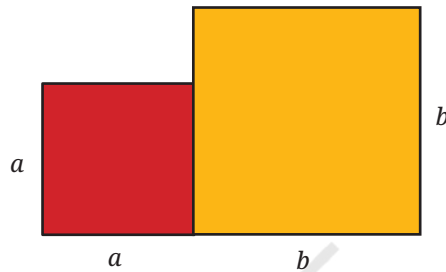

Now make two cuts to make three pieces:

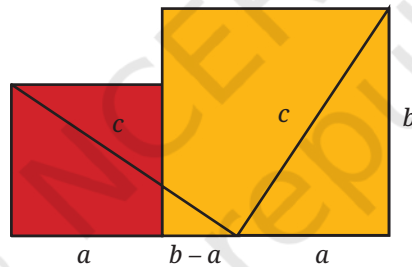

Rearrange the three pieces into a larger square:

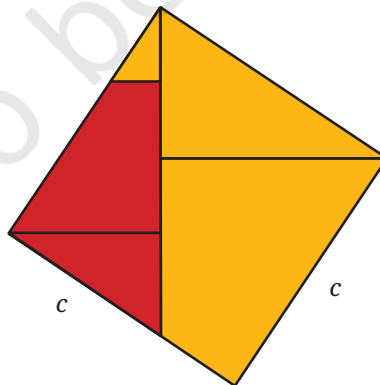

You have now combined two smaller squares into a larger square!

Now make a right triangle using the two smaller squares. Draw a square on the hypotenuse.

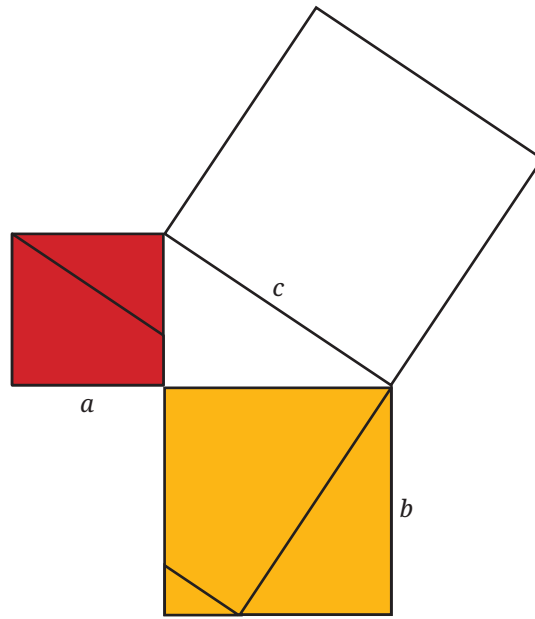

Cover the square on the hypotenuse using your pieces.

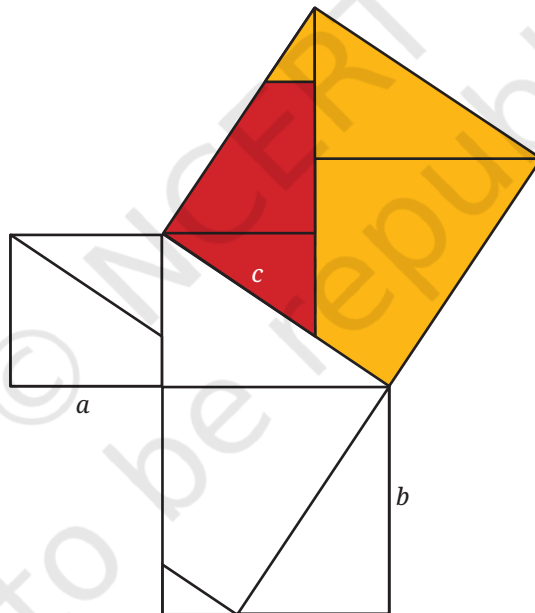

This shows that if a right triangle has shorter sides of length a and b , and hypotenuse of length c , then the areas of the two smaller squares, a^2 and b^2 , add up to the area of the larger square, c^2 :

$$a^2 + b^2 = c^2.$$

This is the famous and fundamental theorem of Baudhāyana on right-angled triangles:

Baudhāyana's Theorem on Right-angled triangles: If a right-angled triangle has sidelengths a , b , and c , where c is the length of the hypotenuse, then $a^2 + b^2 = c^2$.

Baudhāyana was the first person in history to state this theorem in this generality and essentially modern form. The theorem is also known as the Pythagorean Theorem, after the Greek philosopher-mathematician Pythagoras (c. 500 BCE) who also admired and studied this theorem, and lived a couple hundred years after Baudhāyana. It is also often called the transitional name ‘Baudhāyana-Pythagoras Theorem’ so that everyone knows what theorem is being referred to.

Using Baudhāyana’s Theorem

Make a right-angled triangle in your notebook whose shorter sidelengths are 3 cm and 4 cm. Now, measure the length of the hypotenuse. It should read about 5 cm.

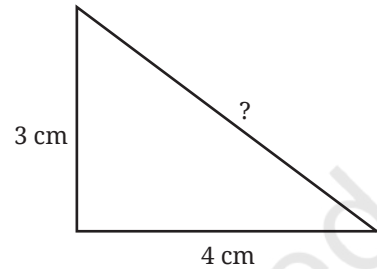

In fact, we could have used Baudhāyana’s Theorem to predict that the hypotenuse is exactly 5 cm! Let $a = 3$ and $b = 4$, the lengths in cm of the two shorter sides. Then, by Baudhāyana’s Theorem, the length c of the hypotenuse satisfies the equation,

$$a^2 + b^2 = c^2$$

$$3^2 + 4^2 = c^2$$

$$9 + 16 = c^2$$

$$25 = c^2$$

$$\text{So, } c = 5 \text{ cm.}$$

? Figure it Out

1. If a right-angled triangle has shorter sides of lengths 5 cm and 12 cm, then what is the length of its hypotenuse? First draw the right-angled triangle with these sidelengths and measure the hypotenuse, then check your answer using Baudhāyana’s Theorem.
2. If a right-angled triangle has a short side of length 8 cm and hypotenuse of length 17 cm, what is the length of the third side? Again, try drawing the triangle and measuring, and then check your answer using Baudhāyana’s Theorem.
3. Using the constructions you have now seen, how would you construct a square whose area is triple the area of a given square? Five times the area of a given square? (Baudhāyana’s *Śulba-Sūtra*, Verse 1.10)
4. Let a , b and c denote the length of the sides of a right triangle, with c being the length of the hypotenuse. Find the missing sidelength in each of the following cases:

(i) $a = 5, b = 7$	(ii) $a = 8, b = 12$	(iii) $a = 9, c = 15$
(iv) $a = 7, b = 12$	(v) $a = 1.5, b = 3.5$	

2.5 Right-Triangles Having Integer Sidelengths

In his *Sūlba-Sūtra* (Verse 1.13) Baudhāyana lists a number of integer triples (a, b, c) that form the sidelengths of a right-triangle and therefore satisfy $a^2 + b^2 = c^2$. These include $(3, 4, 5)$, $(5, 12, 13)$, $(8, 15, 17)$, $(7, 24, 25)$, $(12, 35, 37)$, and $(15, 36, 39)$.

For this reason, such triples (a, b, c) that form the sidelengths of a right triangle (equivalently, satisfy $a^2 + b^2 = c^2$) are called **Baudhāyana triples**. They are also called **Baudhāyana-Pythagoras triples**, **Pythagorean triples**, and **right-angled triangle triples**.

? List down all the Baudhāyana triples with numbers less than or equal to 20.



? Is there an unending sequence of Baudhāyana triples?

Mathematicians have answered this question and have found a method to generate all such triples! Let us take a few steps in this direction.

We have seen that $(3, 4, 5)$ is a Baudhāyana triple.

? Is $(30, 40, 50)$ a Baudhāyana triple?

Is $(300, 400, 500)$ a Baudhāyana triple?

The list of Baudhāyana triples having numbers less than or equal to 20 contains the following triples —

$(3, 4, 5)$, $(6, 8, 10)$, $(9, 12, 15)$, $(12, 16, 20)$.

? Do you see any pattern among them?

All these triples can be obtained by multiplying each term of $(3, 4, 5)$ by a certain positive integer.

? Can we form a conjecture on Baudhāyana triples based on this observation?

Conjecture: $(3k, 4k, 5k)$ is a Baudhāyana triple, where k is any positive integer.

? Is this true?

We have to check if $(3k)^2 + (4k)^2 = (5k)^2$.

We have $(3k)^2 + (4k)^2 = 9k^2 + 16k^2 = 25k^2$, which is equal to $(5k)^2$.

So, $(3k, 4k, 5k)$ is indeed a Baudhāyana triple.

This shows that there are infinitely many Baudhāyana triples.

Can we further generalise the conjecture?

- ? If (a, b, c) is a Baudhāyana triple, then (ka, kb, kc) is also a Baudhāyana triple where k is any positive integer. Is this statement true?

This statement can be shown to be true in the same way. Since (a, b, c) is a Baudhāyana triple, we have $a^2 + b^2 = c^2$. We need to check whether $(ka)^2 + (kb)^2 = (kc)^2$.

$$(ka)^2 = ka \times ka = k^2 a^2, \text{ and } (kb)^2 = kb \times kb = k^2 b^2.$$

$$\text{So, } (ka)^2 + (kb)^2 = k^2 a^2 + k^2 b^2.$$

Taking out the common factor, we have

$$(ka)^2 + (kb)^2 = k^2 (a^2 + b^2).$$

Since $a^2 + b^2 = c^2$, we have

$$(ka)^2 + (kb)^2 = k^2 c^2 = (kc)^2.$$

Thus, (ka, kb, kc) is a Baudhāyana triple if (a, b, c) is a Baudhāyana triple. We call (ka, kb, kc) a **scaled version** of (a, b, c) .

A Baudhāyana triple that does not have any common factor greater than 1 is called a **primitive Baudhāyana triple**. So, $(3, 4, 5)$ is primitive, whereas $(9, 12, 15)$ is not.

- ? Is $(5, 12, 13)$ a primitive Baudhāyana triple? What are the other primitive Baudhāyana triples with numbers less than or equal to 20?
- ? Generate 5 scaled versions of each of these primitive triples. Are these scaled versions primitive?
- ? If (a, b, c) is non-primitive, and the integers have f — greater than 1 — as a common factor, then is $(\frac{a}{f}, \frac{b}{f}, \frac{c}{f})$ a Baudhāyana triple? Check this statement for $(9, 12, 15)$. Justify this statement.

If we can find all the primitive triples, we can find all the Baudhāyana triples.

- ? How do we generate more primitive triples?

We know the relation between the sum of consecutive odd numbers and square numbers.

$$\begin{aligned} 1 &= 1^2 \\ 1 + 3 &= 2^2 \\ 1 + 3 + 5 &= 3^2 \end{aligned}$$

The sum of the first n odd numbers is n^2 . Let us express this algebraically.

- ? For this, we need to know the n th odd number. What is it?

The n th odd number is $2n - 1$. So,

$$\underbrace{1 + 3 + 5 + \dots + (2n - 3)}_{\text{Sum of first } (n - 1) \text{ odd numbers}} + (2n - 1) = n^2$$

? What is the sum of the first $(n - 1)$ odd numbers?

Thus,

$$(n - 1)^2 + (2n - 1) = n^2.$$

Note that this equation could also have been directly obtained by expanding $(n - 1)^2$ and adding $2n - 1$ to it.

If the n th odd number, $2n - 1$, is also a square number, then we have a sum of two square numbers equal to another square number. We will use this idea to generate Baudhāyana triples.

1. 9 is an odd square. It is the 5th odd number ($9 = 2 \times 5 - 1$). So, we have

$$\begin{aligned} 1 + 3 + 5 + 7 + 9 &= 5^2 \\ 4^2 + 3^2 &= 5^2 \end{aligned}$$

? Could we have obtained this triple using the equation $(n - 1)^2 + (2n - 1) = n^2$?

Since we took the 5th odd number, the value of n is 5. Substituting $n = 5$ into the equation, we get

$$\begin{aligned} (5 - 1)^2 + 9 &= 5^2 \\ 4^2 + 3^2 &= 5^2. \end{aligned}$$

2. 25 is an odd square. It is the 13th odd number ($25 = 2 \times 13 - 1$). So,

$$\begin{aligned} 1 + 3 + 5 + \dots + 23 + 25 &= 13^2 \\ 12^2 + 5^2 &= 13^2 \end{aligned}$$

We have $n = 13$.
Substituting this value in
the equation, we get
 $(13 - 1)^2 + 25 = 13^2$
 $12^2 + 5^2 = 13^2$

? **Figure it Out**

- Find 5 more Baudhāyana triples using this idea.
- Does this method yield non-primitive Baudhāyana triples? [Hint: Observe that among the triples generated, one of the smaller sidelengths is one less than the hypotenuse.]
- Are there primitive triples that cannot be obtained through this method? If yes, give examples.



2.6 A Long-Standing Open Problem

The study of Baudhāyana triples inspired the great French mathematician Fermat—who lived during the 17th century—to make a general statement about the sum of powers of positive integers.

We have seen that there are an infinite number of square numbers that can be written as a sum of two square numbers. This made Fermat wonder if there is a perfect cube that can be written as a sum of two perfect cubes, a fourth power that can be written as a sum of two fourth powers, and so on. In other words, he wondered if there is a solution to the equation

$$x^n + y^n = z^n,$$

where $x, y,$ and z are natural numbers, and $n > 2$.

In the margin of a book that dealt with properties and patterns of positive integers (like that of Baudhāyana triples), Fermat wrote that amongst the unending sequence of numbers, one cannot find a single perfect cube that is a sum of two perfect cubes, a fourth power that is a sum of two fourth powers, and so on. So, the equation has no solution for powers greater than 2. In addition to stating this, Fermat wrote,

“I have found a truly marvellous proof of this statement, but the margin is too small to contain it”.



No one could ever find Fermat’s proof of this statement, which is called **Fermat’s Last Theorem**.

After his death, many great mathematicians tried their hand at proving this theorem. There followed more than 300 years of failed attempts in proving it.

In 1963, a 10-year-old boy named Andrew Wiles read a book (*The Last Problem* by Eric Bell) about Fermat’s Last Theorem and its history. Despite reading about the failures of so many great mathematicians, this young boy resolved to prove this theorem.

He eventually did prove this theorem in 1994!

2.7 Further Applications of the Baudhāyana-Pythagoras Theorem

The Baudhāyana-Pythagoras theorem is one of the fundamental theorems of geometry. Let us see some of its applications.

A Problem from Bhāskarāchārya's *Lilāvati*

The following is a translation of a problem from Bhāskarāchārya's (Bhāskara II) *Lilāvati*. Try to visualise what you read.

- “In a lake surrounded by *chakra* and *krauñcha* birds, there is a lotus flower peeping out of the water, with the tip of its stem 1 unit above the water. On being swayed by a gentle breeze, the tip touches the water 3 units away from its original position. Quickly tell the depth of the lake.”

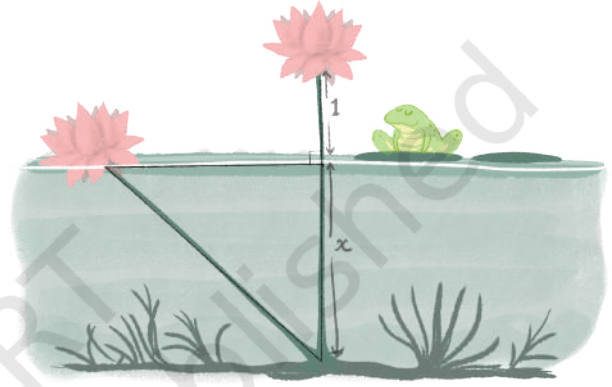

At first glance, it seems like there is insufficient data to find the solution. But the solution exists!

Let x be the length of the stem inside the water. This is the required depth of the lake. Since the stem of the lotus is sticking 1 unit above the water, the total length of the stem is $x + 1$.

We can make a (very reasonable) assumption that the lotus stem is perpendicular to the surface of the water in the first position. With this assumption, we get a right triangle of sides 3, x and $x + 1$. As this satisfies the Baudhāyana-Pythagoras theorem, we have

$$3^2 + x^2 = (x + 1)^2$$

$$9 + x^2 = x^2 + 2x + 1.$$

Subtracting x^2 from both sides, we get

$$9 = 2x + 1.$$

$$x = 4.$$

Thus, the depth of the lake is 4 units.

? Figure it Out

1. Find the diagonal of a square with sidelength 5 cm.
2. Find the missing sidelengths in the following right triangles:

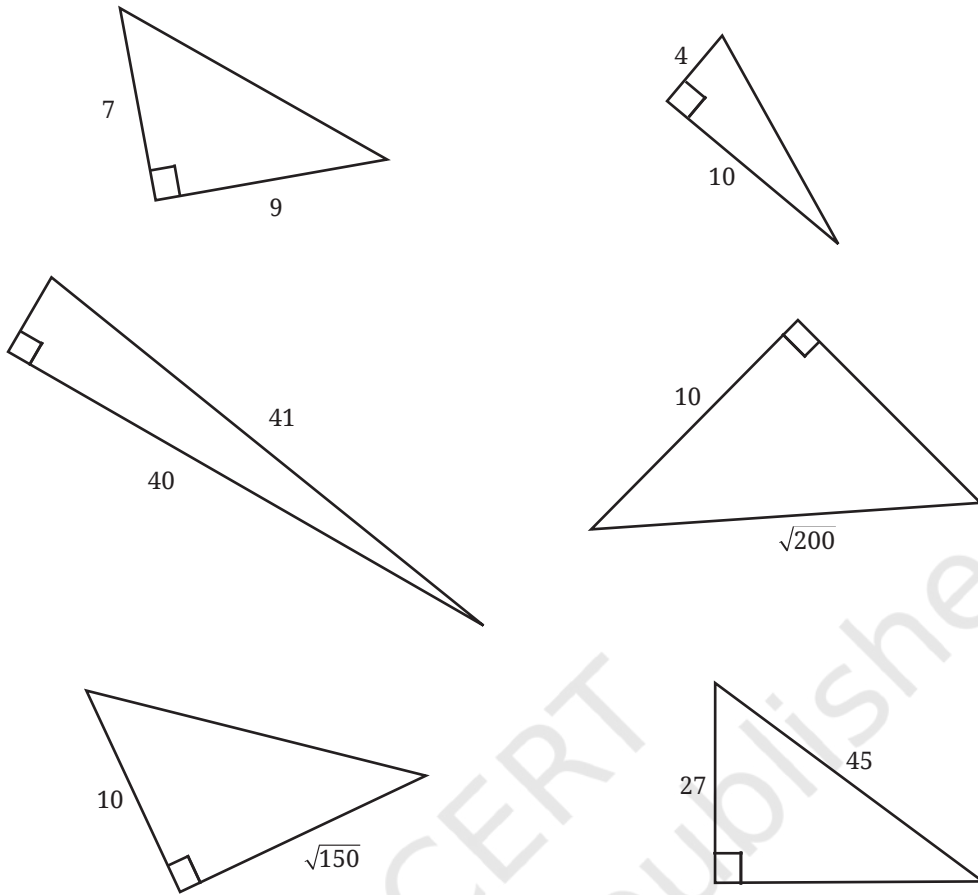

- Find the sidelength of a rhombus whose diagonals are of length 24 units and 70 units.
- Is the hypotenuse the longest side of a right triangle? Justify your answer.
- True or False—Every Baudhāyana triple is either a primitive triple or a scaled version of a primitive triple.
- Give 5 examples of rectangles whose sidelengths and diagonals are all integers.
- Construct a square whose area is equal to the difference of the areas of squares of sidelengths 5 units and 7 units.

- Using the dots of a grid as the vertices, can you create a square that has an area of (a) 2 sq. units, (b) 3 sq. units, (c) 4 sq. units, and (d) 5 sq. unit?
 - Suppose the grid extends indefinitely. What are the possible integer-valued areas of squares you can create in this manner?

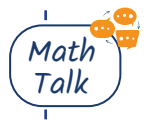
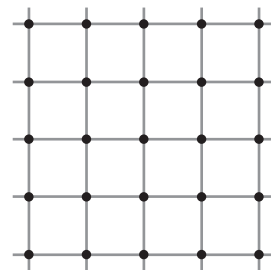

9. Find the area of an equilateral triangle with sidelength 6 units. [Hint: Show that an altitude bisects the opposite side. Use this to find the height.]



Try
This

SUMMARY

- The Baudhāyana-Pythagoras Theorem is one of the most fundamental theorems in geometry. It expresses the relationship among the three sides of a right-angled triangle.
- If a, b, c , are the sidelengths of a right-angled triangle, where c is the length of hypotenuse, then $a^2 + b^2 = c^2$.
- In an isosceles triangle with sidelengths a, a, c , we have the relation $a^2 + a^2 = 2a^2 = c^2$, i.e., $c = a\sqrt{2}$.
- The number $\sqrt{2}$ lies between 1.414 and 1.415. However, it cannot be expressed as a terminating decimal. It also cannot be expressed as a fraction $\frac{m}{n}$ with m, n positive integers.
- A triple (a, b, c) of positive integers satisfying $a^2 + b^2 = c^2$ is called a Baudhāyana-Pythagoras triple. Examples include $(3, 4, 5)$, $(6, 8, 10)$, and $(5, 12, 13)$. Infinitely many such triples can be constructed.
- The equation $a^n + b^n = c^n$ has no solution in positive integers when $n > 2$. This is known as 'Fermat's Last Theorem'. It was proven by Andrew Wiles in 1994.



It's **PUZZLE TIME!**

Find the Colours!

There are 3 closed boxes—one containing only red balls, the second containing only blue balls and the third containing only green balls. The boxes are labelled RED, BLUE and GREEN such that 'no' box has the correct label. We need to find which label goes with which box. How can this be done if we are allowed to open only one box?





3.1 Proportionality—A Quick Recap

In an earlier chapter, we explored proportional relationships between quantities and we used the ratio notation to represent such relationships. When two or more related quantities change by the same factor, we call that relationship a proportional relationship. For example, *idli* batter is made by mixing rice and *urad dal*. The proportion of these two can have regional variations. One of the proportions used is: for 2 cups of rice, we add 1 cup of *urad dal*. We represent this relationship using the ratio notation 2 : 1.

- ?** Viswanath made *idlis* by mixing 6 cups of rice with 3 cups of *urad dal*, while Puneet made *idlis* by mixing 4 cups of rice with 2 cups of *urad dal*. If cooked in the same way, would their *idlis* taste the same?

Viswanath's mixture can be represented as 6 : 3 and Puneet's mixture as 4 : 2.

Recall that, to verify that these two ratios are proportional, we can use the cross-multiplication method:

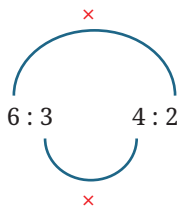

The two products are the same (12). So, the two ratios are proportional. It is likely that the *idlis* would taste the same, if all the other ingredients are proportional too!

In general, we can say that two ratios $a : b$ and $c : d$ are proportional if

$$a \times d = b \times c, \text{ or}$$

$$\frac{a}{c} = \frac{b}{d}.$$

3.2 Ratios in Maps

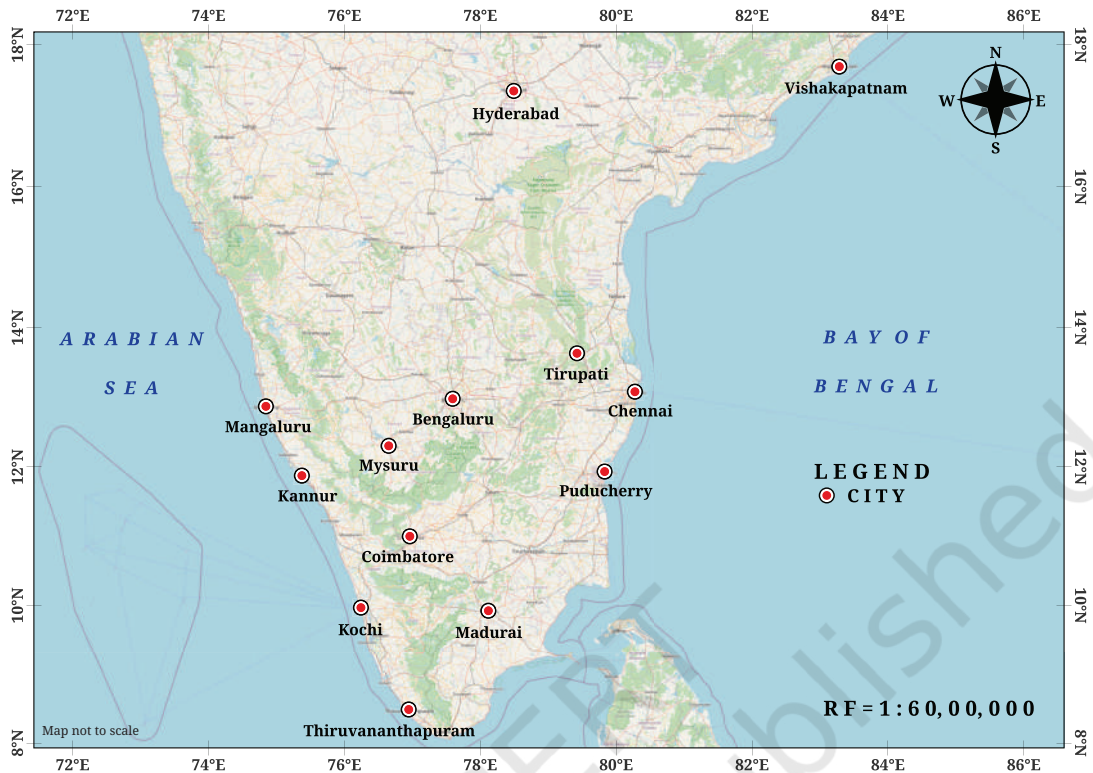

- ? Have you noticed that in many maps there is a ratio given, usually in the lower right corner of the map? It usually contains 1 and a very large number, such as 1 : 60,00,000. What does RF 1 : 60,00,000 mean? What does it indicate? Can you guess?

A Representative Fraction (RF) is an expression that shows the ratio between a distance on the map and the corresponding actual distance on the ground.

For example, if the ratio on a map is 1 : 60,00,000, that means a distance of 1 cm on the map is equivalent to a geographical distance of 60,00,000 cm. Remember, this is geographical distance and not road distance!

- ? Convert 60,00,000 cm to kilometres.
It is 60 km. Verify this.
- ? Using the map above, can you find the geographical distance between Bengaluru and Chennai? Also, find the geographical distance between Mangaluru and Chennai.

[**Hint:** Use a ruler to find the distance between the cities on the map. Then, use the ratio given on the map to find the actual geographical distance.]

- ? Try to find the distances between the same two pairs of cities with different maps that have different scales (ratios). Do they all give the same geographical distance, approximately?

Note to the Teacher: Bring maps and atlases to the classroom and encourage students to observe the scale given as a ratio (usually in the lower right corner) on the map. Use the maps and atlases in the library and ask students to find the geographical distances between two locations on the map that are of local interest. Ask them to verify with each other if they get similar distances and to find the reasons if the distances are very different.

Map Making Activity: Guide students to make a sketch of their classroom with an accurate scale (ratio of 1: 50). They should mark the location of various objects in the classroom like the teacher's desk, blackboard, fans and lights, according to scale. Students can use appropriate symbols to represent different objects like fans, lights, tables, chairs, and so on.

3.3 Ratios with More than 2 Terms

Viswanath is experimenting with a spice mix powder. He makes the powder by grinding 8 spoons of coriander seeds, 4 red chillies, 2 spoons of *toor dal*, and 1 spoon of fenugreek (*methi*) seeds. For his spice mix powder, the ratio of coriander seeds to red chillies to *toor dal* to fenugreek seeds is

$$8 : 4 : 2 : 1.$$

Notice that the ratio has 4 terms. Ratios can have many terms if each of the quantities change by the same factor to maintain the proportional relationship.



- ? Puneet has only 2 red chillies in his kitchen. But he wants to make spice mix powder that tastes the same as Viswanath's spice mix powder. How much of the other ingredients should Puneet use to make his spice mix powder?

For Puneet's spice mix powder to be similar to Viswanath's, the ratio of all the ingredients should be the same as Viswanath's spice mix powder. Puneet has only 2 red chillies. He has half the number of chillies that Viswanath used in his mixture. So, the quantity of the other ingredients should also be reduced to half.

Thus, Puneet should add 4 spoons of coriander seeds, 2 red chillies, 1 spoon of *toor dal*, and half a spoon of fenugreek seeds. The ratio is

$$4 : 2 : 1 : 0.5.$$

Both the ratios are proportional to each other. We denote this by

$$8 : 4 : 2 : 1 :: 4 : 2 : 1 : 0.5.$$

In general, when two ratios with multiple terms are proportional

$$a : b : c : d :: p : q : r : s$$

then,

$$\frac{a}{p} = \frac{b}{q} = \frac{c}{r} = \frac{d}{s}.$$

- ?** **Example 1:** To make a special shade of purple, paint must be mixed in the ratio, Red : Blue : White :: 2 : 3 : 5. If Yasmin has 10 litres of white paint, how many litres of red and blue paint should she add to get the same shade of purple?

In the ratio 2 : 3 : 5, the white paint corresponds to 5 parts.

If 5 parts is 10 litres, 1 part is $10 \div 5 = 2$ litres.

$$\text{Red} = 2 \text{ parts} = 2 \times 2 = 4 \text{ litres.}$$

$$\text{Blue} = 3 \text{ parts} = 3 \times 2 = 6 \text{ litres.}$$

So, the purple paint will have 4 litres of red, 6 litres of blue, and 10 litres of white paint.

- ?** What is the total volume of this purple paint?

The total volume of purple paint is $4 + 6 + 10 = 20$ litres.

- ?** **Example 2:** Cement concrete is a mixture of cement, sand, and gravel, and is widely used in construction. The ratio of the components in the mixture varies depending on how strong the structure needs to be. For structures that need greater strength like pillars, beams, and roofs, the ratio is 1 : 1.5 : 3, and the construction is also reinforced with steel rods. Using this ratio, if we have 3 bags of cement, how many bags of concrete mixture can we make?

The concrete mixture is in the ratio

$$\text{Bags of cement} : \text{bags of sand} : \text{bags of gravel} :: 1 : 1.5 : 3.$$

If we have 3 bags of cement, we have to multiply the other terms by 3. So, the ratio is

$$\text{cement} : \text{sand} : \text{gravel} :: 3 : 4.5 : 9.$$

In total, we have $3 + 4.5 + 9 = 16.5$ bags of concrete.

3.4 Dividing a Whole in a Given Ratio

In an earlier chapter, we learnt how to divide a whole in a ratio, e.g., 12 in the ratio 2 : 1. To do this, we add the terms ($2 + 1 = 3$), and divide the whole by this sum ($12 \div 3 = 4$). We multiply each term by this quotient: $2 \times 4 = 8$ and $1 \times 4 = 4$. So, 12 divided in the ratio 2 : 1 is 8 : 4.

We can extend this to ratios with multiple terms.

Let us look at the earlier example of making a concrete mixture. We need to mix cement, sand, and gravel in the ratio of 1 : 1.5 : 3 to get the concrete.

? **Example 3:** For some construction, 110 units of concrete are needed. How many units of cement, sand, and gravel are needed if these are to be mixed in the ratio 1 : 1.5 : 3?

For 1 unit of cement, we need to add 1.5 units of sand and 3 units of gravel. Together, they add up to 5.5 units of concrete. We need to do this 20 times ($110 \div 5.5 = 20$) to get 110 units of concrete. So each term has to be multiplied by 20.

$$\begin{aligned} 1 \times 20 &= 20 \text{ units of cement,} \\ 1.5 \times 20 &= 30 \text{ units of sand, and} \\ 3 \times 20 &= 60 \text{ units of gravel.} \end{aligned}$$

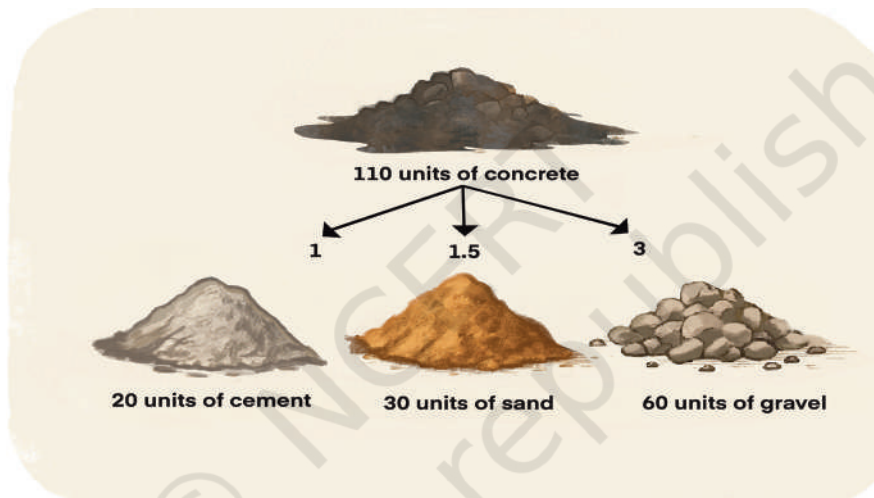

So, we need 20 units of cement, 30 units of sand, and 60 units of gravel to make the concrete.

When we divide a quantity x in the ratio $a : b : c : \dots$, the terms in the ratio are—

$$x \times \frac{a}{(a+b+c+\dots)}, x \times \frac{b}{(a+b+c+\dots)}, x \times \frac{c}{(a+b+c+\dots)}, \text{ and so on.}$$

? **Example 4:** You get a particular shade of purple paint by mixing red, blue, and white paint in the ratio 2 : 3 : 5. If you need 50 ml of purple paint, how many ml of red, blue, and white paint will you mix together?

$$\text{Red paint} = 50 \times \frac{2}{(2+3+5)} = 50 \times \frac{2}{10} = 10 \text{ ml.}$$

$$\text{Blue paint} = 50 \times \frac{3}{(2+3+5)} = 50 \times \frac{3}{10} = 15 \text{ ml.}$$

$$\text{White paint} = 50 \times \frac{5}{(2+3+5)} = 50 \times \frac{5}{10} = 25 \text{ ml.}$$

Example 5: Construct a triangle with angles in the ratio 1 : 3 : 5.

We know that the sum of the angles in a triangle is 180° . So the angles are

$$\angle A = 180^\circ \times \frac{1}{(1+3+5)} = 180^\circ \times \frac{1}{9} = 20^\circ.$$

$$\angle B = 180^\circ \times \frac{3}{(1+3+5)} = 180^\circ \times \frac{3}{9} = 60^\circ.$$

$$\angle C = 180^\circ \times \frac{5}{(1+3+5)} = 180^\circ \times \frac{5}{9} = 100^\circ.$$

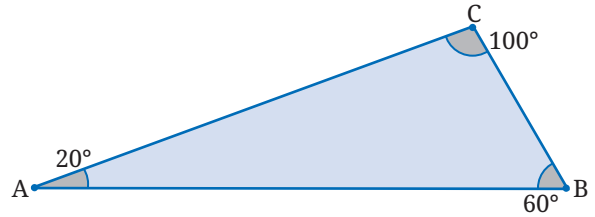
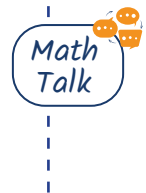

Figure it Out

1. A cricket coach schedules practice sessions that include different activities in a specific ratio — time for warm-up/cool-down : time for batting : time for bowling : time for fielding :: 3 : 4 : 3 : 5. If each session is 150 minutes long, how much time is spent on each activity?
2. A school library has books in different languages in the following ratio — no. of Odiya books : no. of Hindi books : no. of English books :: 3 : 2 : 1. If the library has 288 Odiya books, how many Hindi and English books does it have?
3. I have 100 coins in the ratio — no. of ₹10 coins : no. of ₹5 coins : no. of ₹2 coins : no. of ₹1 coins :: 4 : 3 : 2 : 1. How much money do I have in coins?
4. Construct a triangle with sidelengths in the ratio 3 : 4 : 5. Will all the triangles drawn with this ratio of sidelengths be congruent to each other? Why or why not?
5. Can you construct a triangle with sidelengths in the ratio 1 : 3 : 5? Why or why not?



3.5 A Slice of the Pie

Have you seen pie charts like the one shown in the figure? Pie charts show different proportions of a whole. This one shows the proportions of students that have scored each grade in an assessment. These kinds of visualisations help us quickly interpret data.

Let us try to create this pie chart. Here is a table showing the grades scored by students:

Grade	A	B	C	D	E
Students	12	10	8	6	4

Grade Distribution (40 students)

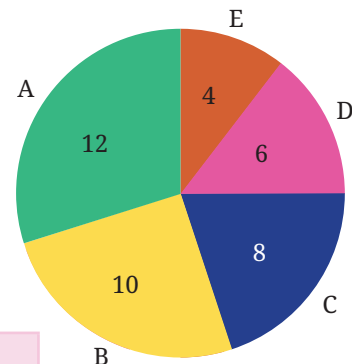

? How do we mark the different slices of the pie chart?

To mark a slice in the pie chart, the angle corresponding to a grade should be proportional to the number of students who have scored that grade. The total angle in a circle is 360° . So, we need to divide 360 in the ratio of $12 : 10 : 8 : 6 : 4$.

? Can we reduce this ratio to its simplest form?

We can use the same procedure we used to reduce a ratio with two terms to its simplest form. We divide all the terms by their HCF to get the simplest form.

In this example, 2 is the HCF of the terms. We get the simplest form by dividing all the terms by 2. The ratio becomes $6 : 5 : 4 : 3 : 2$.

So, the angles are:

$$\text{Grade A} = \frac{6}{(6 + 5 + 4 + 3 + 2)} \times 360^\circ = \frac{6}{20} \times 360^\circ = 6 \times 18 = 108^\circ.$$

$$\text{Grade B} = \frac{5}{(6 + 5 + 4 + 3 + 2)} \times 360^\circ = 5 \times 18 = 90^\circ.$$

$$\text{Grade C} = 4 \times 18 = 72^\circ.$$

$$\text{Grade D} = 3 \times 18 = 54^\circ.$$

$$\text{Grade E} = 2 \times 18 = 36^\circ.$$

Now let us construct a pie chart using these angles.

Step 1: Draw a circle and mark the radius AB as shown below:

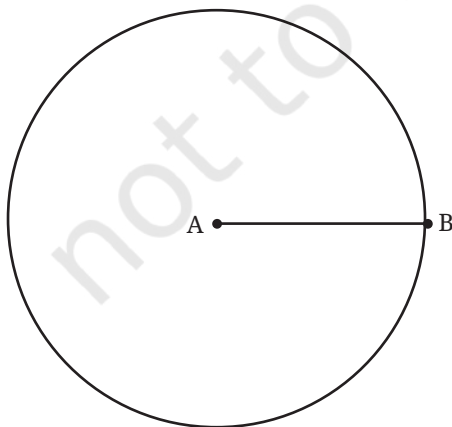

Step 2: To draw the slice to represent the proportion of students who got an A grade, measure 108° from the segment AB on A (anti-clockwise), and mark the new radius AC.

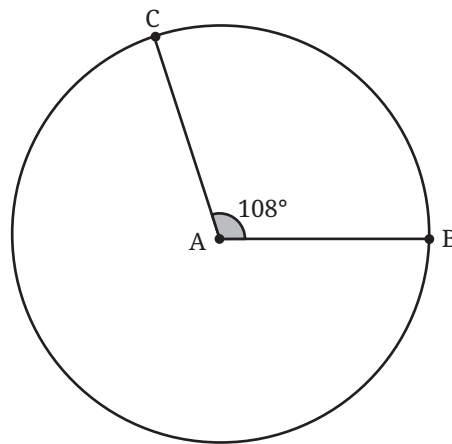

Step 3: Measure 90° from AC and draw AD.

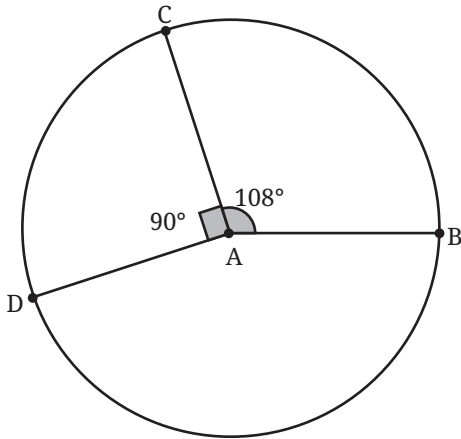

Step 4: Measure 72° from AD and draw AE.

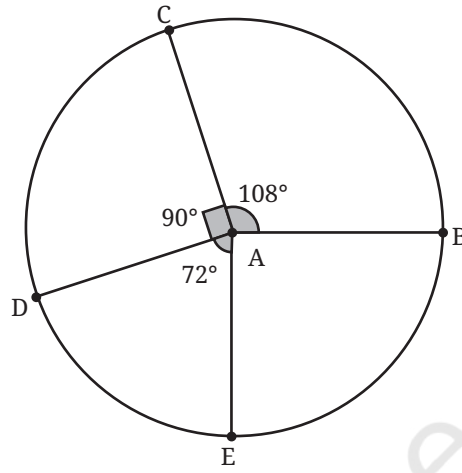

Steps 5,6: Similarly, we can complete the rest of the pie chart.

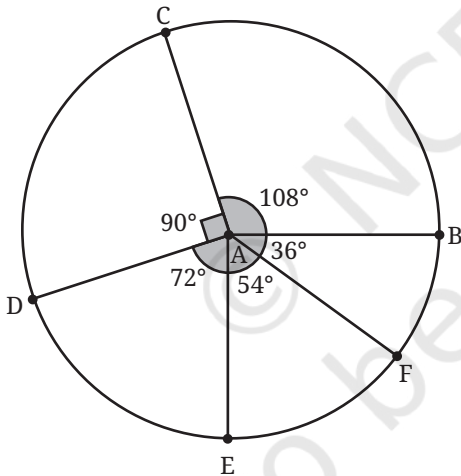

Step 7: You can colour and label the different slices of the pie chart appropriately.

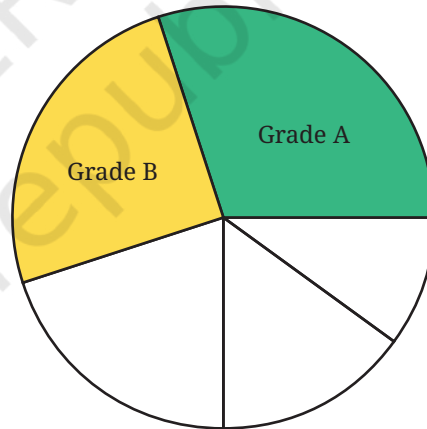

? Figure it Out

1. A group of 360 people were asked to vote for their favourite season from the three seasons—rainy, winter and summer. 90 liked the summer season, 120 liked the rainy season, and the rest liked the winter. Draw a pie chart to show this information.
2. Draw a pie chart based on the following information about viewers' favourite type of TV channel: Entertainment—50%, Sports—25%, News—15%, Information—10%.
3. Prepare a pie chart that shows the favourite subjects of the students in your class. You can collect the data of the number of students for

each subject shown in the table (each student should choose only one subject). Then write these numbers in the table and construct a pie chart:

Subject	Language	Arts Education	Vocational Education	Social Science	Physical Education	Maths	Science
Number of Students							

3.6 Inverse Proportions

Do you recall the rule of three? When two ratios are proportional, i.e., when

$a : b :: c : d$, then $d = \frac{bc}{a}$. We call such proportions **direct proportions**. We use this understanding to find the value of the fourth quantity (d), when the value of three quantities (a , b , and c) are given.

- ?** **Example 1:** If 5 workers can move 4500 bricks in a day, how many workers are needed to move 18000 bricks in a day?

This can be represented as a statement of proportionality— $4500 : 18000 :: 5 : x$. We can find the value of x by

$$x = \frac{18000 \times 5}{4500} = 20$$

Thus, the number of workers needed are 20.

- ?** **Example 2:** Puneeth's father went from Lucknow to Kanpur in 3 hours by riding his motorcycle at a speed of 30 km/h. If he takes a car instead and drives at 60 km/h, how long will it take him to reach Kanpur?

- ?** Can we represent this problem with the following statement of proportionality— $30 : 60 :: 3 : x$? Will the travel time increase or decrease as the speed of the motorcycle increases?

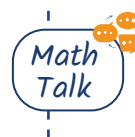

The following table shows the time taken to travel from Lucknow to Kanpur using different modes of transport:

	Walk	Bicycle	Motorcycle	Car
Speed (km/h)	5	15	30	60
Time (in hours)	18	6	3	1.5

From this table, we notice that when the speed **increases**, the time taken to travel the same distance **decreases**.

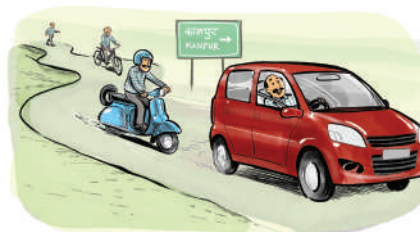

? Does it decrease by the same rate (or factor)?

Going by bicycle is 3 times faster than walking ($15 \div 5$). The speed has increased 3 times. The travel time has decreased 3 times too ($18 \div 6$). The speed has increased by the same factor by which the travel time has decreased.

? Check if this is the case for the other modes of transport.

Since both quantities, speed and time, change by the same factor, they are proportional. But they change in opposite directions, or inversely. Such proportions are called **inverse proportions**.

From the table, we can see that the product of speed and time are the same for all modes of transport, namely 90 km.

Two quantities x and y vary in inverse proportion if there exists a relation of the type $xy = k$, where k is a constant.

In the previous example, if x represents the speed and y represents the time taken, then k is the distance between Lucknow and Kanpur, which remains constant.

Speed (km/h)	5	15	30	60
Time (in hours)	18	6	3	1.5

Diagram illustrating the relationships between the values in the table:

- From 5 to 15: $\times 3$
- From 15 to 30: $\times 2$
- From 30 to 60: $\times 4$
- From 18 to 6: $\times \frac{1}{3}$
- From 6 to 3: $\times \frac{1}{2}$
- From 3 to 1.5: $\times \frac{1}{4}$

Thus, if quantities x and y are inversely proportional, and x_1 and x_2 are values of x that have corresponding y values y_1 and y_2 , then

$$x_1 y_1 = x_2 y_2 = k \text{ (some constant).}$$

From these we can see that $\frac{x_1}{x_2} = \frac{y_2}{y_1}$.

Let us check if this is true for other modes of transport, such as walking and by car. Let us use x to represent speed and y to represent time.

$$x_1 = 5, x_2 = 60, y_1 = 18, y_2 = 1.5.$$

$$\frac{x_1}{x_2} = \frac{5}{60} = 0.083333\dots$$

What is the value of $\frac{1.5}{18} \left(\frac{y_2}{y_1} \right)$? It is 0.083333... too!

? Figure it Out

1. Which of these are in inverse proportion?

(i)

x	40	80	25	16
y	20	10	32	50

(ii)

x	40	80	25	16
y	20	10	12.5	8

(iii)

x	30	90	150	10
y	15	5	3	45

2. Fill in the empty cells if x and y are in inverse proportion.

x	16	12		36
y	9		48	

? Example 3: 20 workers take 4 days to complete laying a road. How many days will 10 workers take to complete laying the same length of road?

If we decrease the number of workers, then the number of days to complete the work will increase by the same factor. So these quantities are inversely proportional. So, $x_1y_1 = x_2y_2$.

Thus, $20 \times 4 = 10 \times y_2$

$$y_2 = \frac{20 \times 4}{10} = 8.$$

It will take 8 days for 10 workers to complete the work.

We notice that when the number of workers halved, the number of days to complete the work doubled. Quantities are inversely proportional if, when one quantity changes by a factor n , the other quantity changes by the inverse $\frac{1}{n}$.

- ?** **Example 4:** 2 pumps can fill a tank in 18 hours. How much time will it take to fill the tank if we add 2 more pumps of the same kind?

If we add 2 more pumps, we will have 4 pumps. Let us denote the time taken to fill the tank with 4 pumps by x . If we increase the number of pumps by n , then the time taken to fill the tank will decrease by the same factor n , so the quantities are inversely proportional. Since the quantities are inversely proportional, the product remains constant. So,

$$2 \times 18 = 4 \times x.$$

$$x = \frac{2 \times 18}{4} = 9.$$

It will take 9 hours to fill the tank.

- ?** **Example 5:** A school has food provisions to feed 80 students for 15 days. If 20 more students join the school, for how many days will the provisions last?

More students \rightarrow fewer days the provisions will last. The quantities are inversely proportional. If x is the number of days,

$$80 \times 15 = 100 \times x.$$

$$x = \frac{80 \times 15}{100} = 12.$$

The provisions will last for only 12 days.

- ?** **Example 6:** If Ram takes 1 hour to cut a given quantity of vegetables and Shyam takes 1.5 hours to cut the same quantity of vegetables, how much time will they take to cut the vegetables if they do it together?

Consider the work done to cut the given quantity of vegetables as 1 unit of work. Let us figure out the work done by each person in 1 hour.

- Ram finishes the work in 1 hour, so in 1 hour he does 1 unit of work.
- Shyam finishes the work in 1.5 hours, so in 1 hour he does $\frac{1}{1.5} = \frac{2}{3}$ units of work.

So, the work done by both in 1 hour is $1 + \frac{2}{3} = \frac{5}{3}$ units of work.

Therefore, to complete $\frac{5}{3}$ units of work, it takes them 1 hour if they work together. How much time will it take them to complete 1 unit of work?

Is the quantity of work and time taken to complete it directly or inversely proportional?

It is directly proportional. So, this can be represented as

$$\frac{5}{3} : 1 :: 1 : x \text{ where } x \text{ is the time taken.}$$



Since it is a direct proportion, we know that

$$\frac{5}{3} \times x = 1 \times 1$$

$$x = \frac{1 \times 1}{\frac{5}{3}} = \frac{1}{\frac{5}{3}} = \frac{3}{5}$$

If they cut the vegetables together, they will finish in $\frac{3}{5}$ hours.

? Figure it Out

1. Which of the following pairs of quantities are in inverse proportion?
 - (i) The number of taps filling a water tank and the time taken to fill it.
 - (ii) The number of painters hired and the days needed to paint a wall of fixed size.
 - (iii) The distance a car can travel and the amount of petrol in the tank.
 - (iv) The speed of a cyclist and the time taken to cover a fixed route.
 - (v) The length of cloth bought and the price paid at a fixed rate per metre.
 - (vi) The number of pages in a book and the time required to read it at a fixed reading speed.
2. If 24 pencils cost ₹120, how much will 20 such pencils cost?
3. A tank on a building has enough water to supply 20 families living there for 6 days. If 10 more families move in there, how long will the water last? What assumptions do you need to make to work out this problem?
4. Fill in the average number of hours each living being sleeps in a day by looking at the charts. Select the appropriate hours from this list: 15, 2.5, 20, 8, 3.5, 13, 10.5, 18.

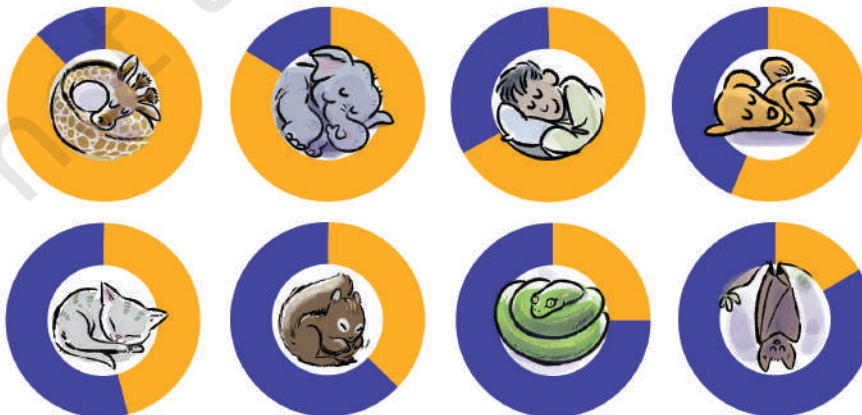
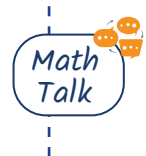

5. The pie chart on the right shows the result of a survey carried out to find the modes of transport used by children to go to school. Study the pie chart and answer the following questions.

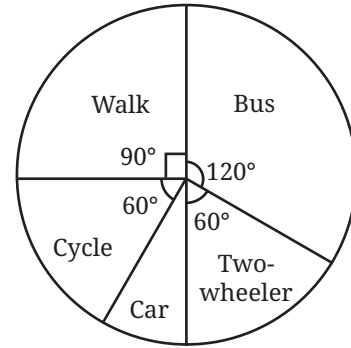

- (i) What is the most common mode of transport?
 - (ii) What fraction of children travel by car?
 - (iii) If 18 children travel by car, how many children took part in the survey? How many children use taxis to travel to school?
 - (iv) By which two modes of transport are equal numbers of children travelling?
6. Three workers can paint a fence in 4 days. If one more worker joins the team, how many days will it take them to finish the work? What are the assumptions you need to make?
7. It takes 6 hours to fill 2 tanks of the same size with a pump. How long will it take to fill 5 such tanks with the same pump?
8. A given set of chairs are arranged in 25 rows, with 12 chairs in each row. If the chairs are rearranged with 20 chairs in each row, how many rows does this new arrangement have?
9. A school has 8 periods a day, each of 45 minutes duration. How long is each period, if the school has 9 periods a day, assuming that the number of school hours per day stays the same?
10. A small pump can fill a tank in 3 hours, while a large pump can fill the same tank in 2 hours. If both pumps are used together, how long will the tank take to fill?



11. A factory requires 42 machines to produce a given number of toys in 63 days. How many machines are required to produce the same number of toys in 54 days?
12. A car takes 2 hours to reach a destination, travelling at a speed of 60 km/h. How long will the car take if it travels at a speed of 80 km/h?

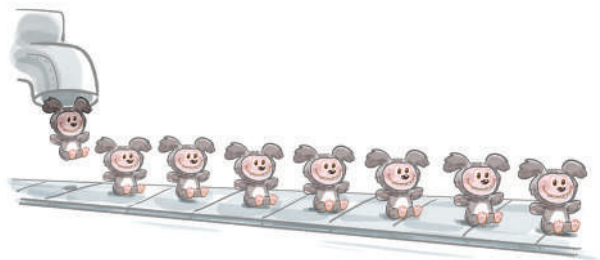

SUMMARY

- Ratios in the form $a : b : c : d : \dots$ indicate that for every a units of the first quantity, there are b units of the second quantity, c units of the third quantity, and so on.
- If x is divided into many parts in the ratio $p : q : r : s : \dots$, then the quantity of the first part is $x \times \frac{p}{(p+q+r+s+\dots)}$, the quantity of the second part is $x \times \frac{q}{(p+q+r+s+\dots)}$, and so on.
- Two quantities are directly proportional when they both change by the same factor, and their quotient remains the same. For example, if x and y are two quantities that are directly proportional, and (x_1, x_2, x_3, \dots) and (y_1, y_2, y_3, \dots) are the corresponding values of x and y , then $\frac{x_1}{y_1} = \frac{x_2}{y_2} = \frac{x_3}{y_3} = \dots = k$, where k is a constant.
- Quantities are inversely proportional if, when one quantity changes by a factor n , the other quantity changes by the inverse $\frac{1}{n}$. For example, if x and y are two quantities that are inversely proportional, and (x_1, x_2, x_3, \dots) and (y_1, y_2, y_3, \dots) are the corresponding values of x and y , then $x_1 y_1 = x_2 y_2 = x_3 y_3 = \dots = n$, where n is a constant.

4

EXPLORING SOME GEOMETRIC THEMES



In this chapter, we will explore two geometric themes. We will study fractals which are self-similar shapes. They exhibit the same or similar pattern over and over again — but at smaller and smaller scales. We will then look at different ways of visualising solids.

4.1 Fractals

One of the most beautiful examples of a fractal that also occurs in nature is the fern. The fern is seen to have smaller copies of itself as its leaves, and these in turn have even smaller copies of themselves in their sub-leaves, and so on!

Similar phenomena of self-similarity occur in trees (where a trunk has limbs, and a limb has branches, and the branches have branchlets, and so on), clouds, coastlines, mountains, lightning, and many other objects in nature.

Other mathematical fractals can also be very beautiful. We will explore some of them here.



Sierpinski Carpet

The Polish mathematician Sierpinski discovered a type of fractal known as the **Sierpinski Carpet**. It is made by taking a square, breaking it into 9 smaller squares, and then removing the central square (see the figure below); the same procedure is then repeated on the remaining 8 squares, and so on. One then sees the same pattern at smaller and smaller scales.

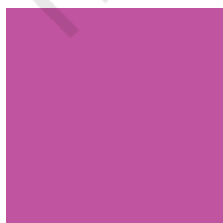

Step 0

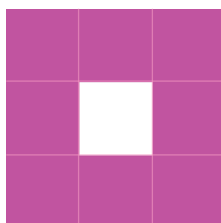

Step 1

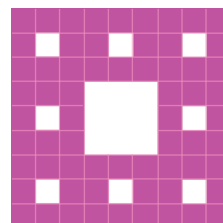

Step 2

...

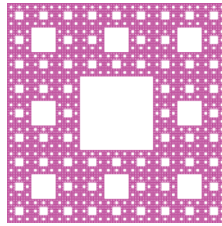

Sierpinski Carpet

- ? Draw the initial few steps (at least till Step 2) of the shape sequence that leads to the Sierpinski Carpet.

By its construction, each step in the sequence has

- (i) squares of the same size that remain in the figure, and the size of these squares becomes smaller and smaller as the step number increases, and
 - (ii) square holes that are formed by removing square pieces.
- ? Do you see any pattern in the number of holes and squares that remain at each step?

Let R_n represent the number of remaining squares at the n th step, and H_n represent the number of holes at the n th step.

Let us understand how these numbers grow by analysing how the holes and squares that remain are generated from the previous step.

Every square that remains at a given step, say Step n , gives rise to 8 squares that remain at the $(n + 1)$ th step. Thus, we have

$$R_{n+1} = 8 R_n.$$

- ? Can this be used to get a formula for R_n ?

We have

$$\begin{aligned} R_0 &= 1 \\ R_1 &= 8 \times 1 = 8 \\ R_2 &= 8 \times 8 = 8^2. \end{aligned}$$

In general, $R_n = 8^n$.

- ? Similarly, how do we find the number of holes at a given step?

Every square that remains at the n th step gives rise to a hole in the $(n + 1)$ th step. All the holes present at the n th step remain in the $(n + 1)$ th step as well. Thus,

$$H_{n+1} = H_n + R_n.$$

So we have

$$\begin{array}{ll} R_0 = 1 & H_0 = 0 \\ R_1 = 8 & H_1 = 1 \\ R_2 = 8^2 & H_2 = 1 + 8 \\ R_3 = 8^3 & H_3 = 1 + 8 + 8^2 \\ & \vdots \end{array}$$

Sierpinski Gasket

Sierpinski came up with another fractal made in a similar way. An equilateral triangle is broken up into 4 identical equilateral triangles by joining the midpoints of the bigger triangle, and then the central triangle is removed. This procedure is repeated on the 3 remaining triangles, and so on.

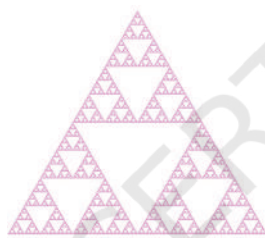
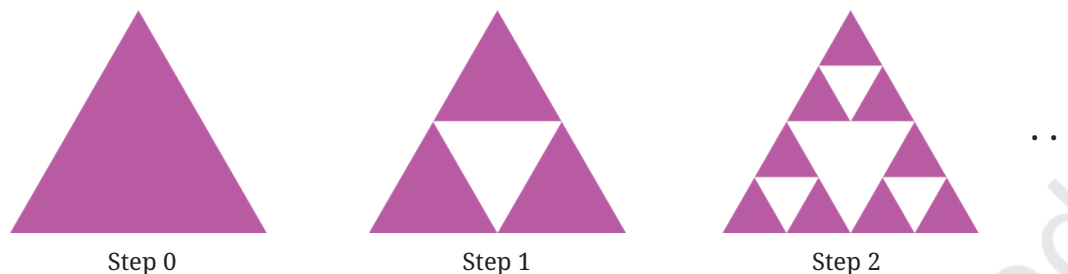

Sierpinski Triangle

- ? Show that by joining the midpoints of an equilateral triangle, we divide it into 4 identical equilateral triangles.

[Hint: Note that the corner triangles are isosceles.]

This fractal is called the **Sierpinski Triangle/Gasket**.

? Figure it Out

1. Draw the initial few steps (at least till Step 2) of the shape sequence that leads to the Sierpinski Triangle.
2. Find the number of holes, and the triangles that remain at each step of the shape sequence that leads to the Sierpinski Triangle.
3. Find the area of the region remaining at the n th step in each of the shape sequences that lead to the Sierpinski fractals. Take the area of the starting square/triangle to be 1 sq. unit.

Koch Snowflake

The Koch Snowflake is another fractal, named after the Swedish mathematician Von Koch, who first described it in 1904. We have already encountered this fractal in Grade 6, *Ganita Prakash*.

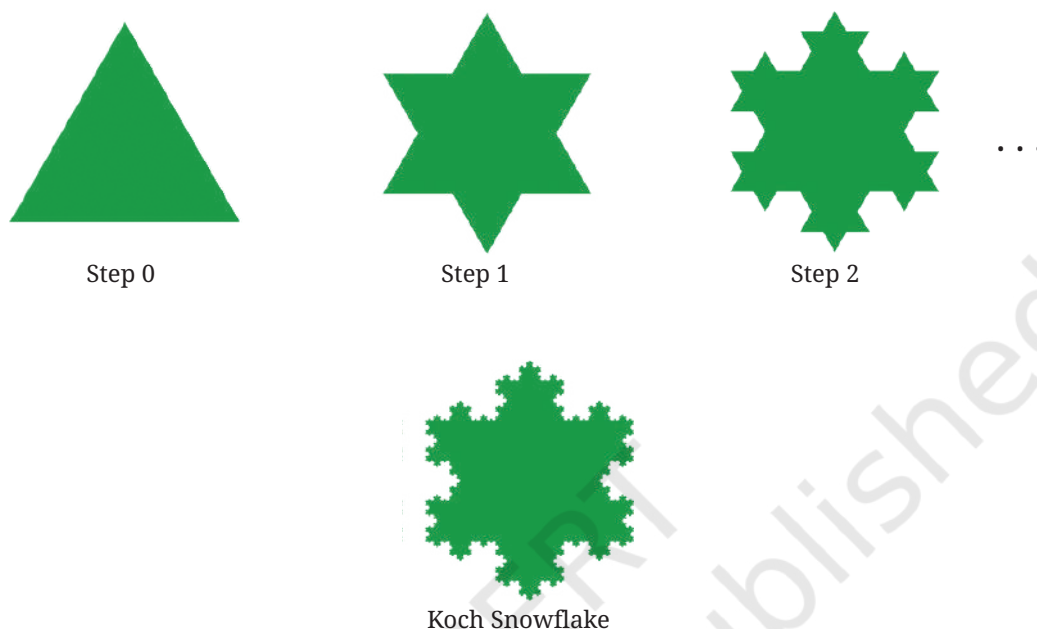

To generate it, we start with an equilateral triangle. Each side is

- (i) divided into 3 equal parts, and
- (ii) an equilateral triangle is raised over the middle part, and then the middle part is removed.

Effectively, each side gets replaced by a 'bump' - shaped structure . This procedure is repeated on the sides of the new resulting shape, and so on.

? Figure it Out

1. Draw the initial few steps (at least till Step 2) of the shape sequence that leads to the Koch Snowflake.
2. Find the number of sides in the n th step of the shape sequence that leads to the Koch Snowflake.
3. Find the perimeter of the shape at the n th step of the sequence. Take the starting equilateral triangle to have a sidelength of 1 unit.

Fractals in Art

Fractals have also long been used in human-made art! Perhaps the oldest such fractals appear in the temples of India. An example occurs in the Kandariya Mahadev Temple in Khajuraho, Madhya Pradesh which was completed in around 1025 C.E.; there one sees a tall temple structure, which is made up of smaller copies of the full structure, on which there are even smaller copies of the same structure, and so on. Fractal-like patterns also occur in temples in Madurai, Hampi, Rameswaram, Varanasi, among many others.



Kandariya Mahadev Temple

Fractals are also common in traditional African cultures. For example, patterns on Nigerian Fulani wedding blankets often exhibit fractal structures.



Nigerian Fulani Wedding Blanket

In the blanket shown in the figure, there are diamond shaped patterns, inside of which there are smaller diamond shaped patterns, and so on.

The modern maestro of fractal art is undoubtedly the Dutch artist M.C. Escher. We have already seen that some of his prints explore the mathematical theme of tiling. One famous example involving fractals is his work ‘Smaller and Smaller’, which exhibits the identical pattern of lizards but at smaller and smaller scales. Here is a print inspired by Escher’s ‘Smaller and Smaller’.



4.2 Visualising Solids

Build it in Your Imagination

- ?** We will start this section by practising visualisation. For each prompt, feel free to talk to your partner, gesture, draw it in the air — but do not actually draw on paper!

My method is different. I do not rush into actual work. When I get an idea I start at once building it up in my imagination. I change the construction, make improvements, and operate the device entirely in my mind.

—Nikolas Tesla (1856–1943), the great Serbian-American engineer and inventor, who made fundamental contributions to electrical engineering and other fields.

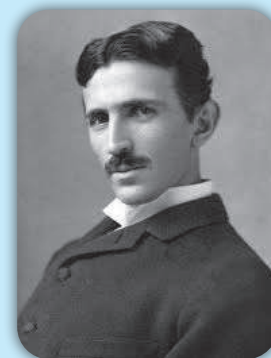

1. Picture your name, then read off the letters backwards. Make sure to do this by sight, not by sound — really see your name! Now try with your friend’s name.

2. Cut off the four corners of an imaginary square, with each cut going between midpoints of adjacent edges. What shape is left over? How can you reassemble the four corners to make another square?
3. Mark the sides of an equilateral triangle into thirds. Cut off each corner of the triangle, as far as the marks. What shape do you get?
4. Mark the sides of a square into thirds and cut off each of its corners as far as the marks. What shape is left?

When we see a solid object, we are really seeing its **profile** from a specific viewpoint. Depending on our viewpoint, the **outline** of this profile can vary dramatically!

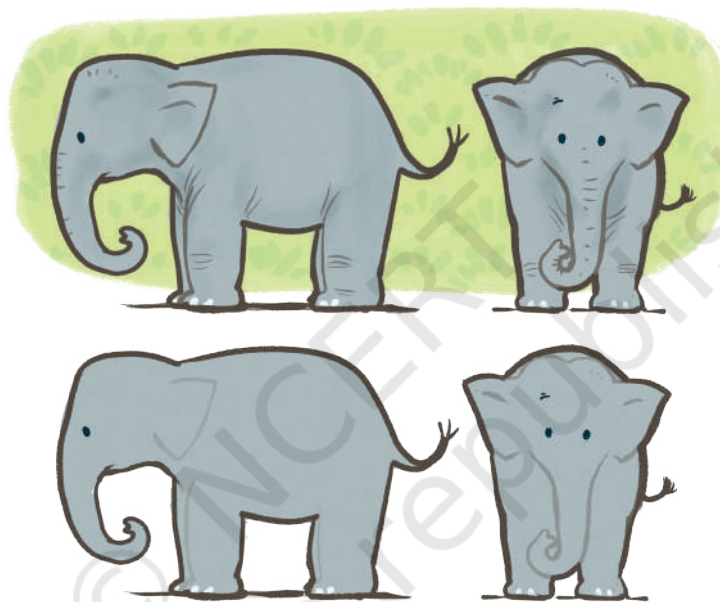

Perhaps you've noticed interesting profiles of objects yourself, while taking a photograph or observing the shadow of an object? Or, maybe you've seen a cartoon like the following, in which a character bursts through a wall and leaves a hole shaped like their outline!



In previous classes, you've seen solids that are much simpler than an elephant or cat, such as cubes, spheres, cylinders, and cones. What would the profiles of these look like, from different viewpoints?

? Can you describe a solid and a viewpoint that would result in each of the following cases? If it helps, you can imagine the solid passing through a wall like Tom did, and leaving a hole of the appropriate shape.

5. A solid whose profile has a square outline
6. A solid whose profile has a circular outline
7. A solid whose profile has a triangular outline

? As we saw with the elephant, a given solid might have very different profiles from different viewpoints. Can you visualise solids that have the following contrasting profiles?

Spend some time on this, and if you are finding it difficult to visualise, you may look around and use objects that are around you, or that you will make in the next section. Feel free to consider viewpoints from any direction, including directly above the object.

8. A solid with a rectangular profile from one viewpoint and a circular profile from another viewpoint
9. A solid with a circular profile from one viewpoint and a triangular one from another viewpoint
10. A solid with a rectangular profile from one viewpoint and a triangular one from another viewpoint
11. A solid with a trapezium shaped profile from one viewpoint and a circular one from another viewpoint
12. A solid with a pentagonal profile from one viewpoint and a rectangular one from another viewpoint

? Are there unique solids for each of the conditions, or can you come up with multiple possibilities?

Making Solids

Many basic solid shapes such as a cuboid, parallelepiped, cylinder, cone, prism, and pyramid can be made using foldable flat materials like paper, cardboard, and even metallic sheets! This is one of the methods for manufacturing hollow solids.

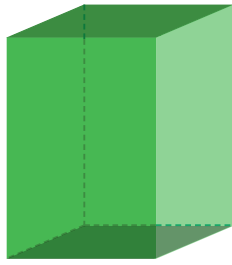

Cuboid

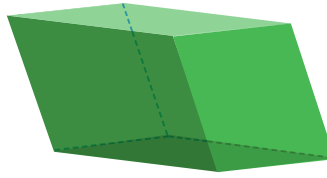

Parallelepiped



Cylinder

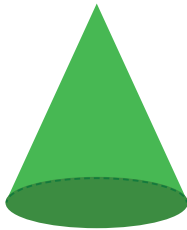

Cone



Triangular prism

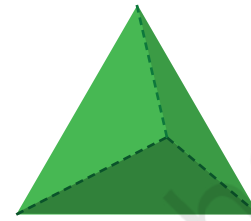

Triangular pyramid

While discussing solids that contain plane surfaces in their boundaries, the notion of faces, edges and vertices serves a useful purpose.

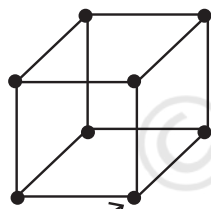

Vertex

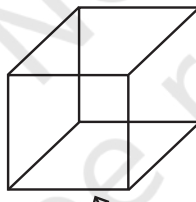

Edge

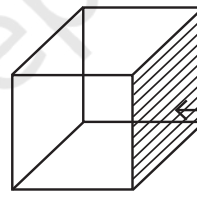

Face

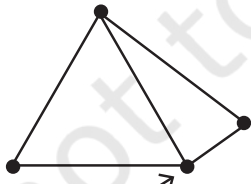

Vertex

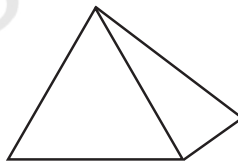

Edge

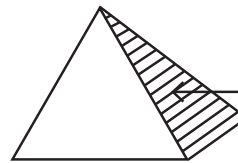

Face

Faces are the plane/flat surfaces of a solid that form its boundary. **Edges** are the line segments that form the sides of the faces, and **vertices** are the points at which the edges meet. For example, a cuboid or cube has 6 faces, 12 edges and 8 vertices.

There are multiple types of prisms and pyramids, whose names depend on the shapes of their faces.

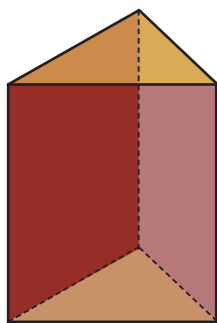

Triangular
Prism

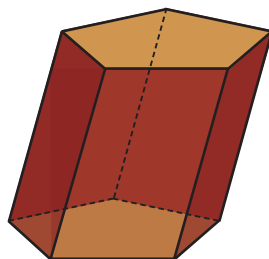

Pentagonal
Prism

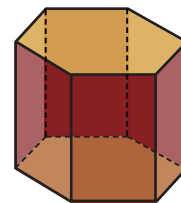

Hexagonal
Prism

Prism: A prism, in general, has two congruent polygons as opposite faces, with edges connecting the corresponding vertices of these polygons. All the other faces are parallelograms. Based on the shape of the congruent polygons, prisms may be called triangular prisms, pentagonal prisms, and so on.

Pyramids: A pyramid, in general, has a polygonal base and a point outside it, and edges connect the point with each of the vertices of the base. Based on the shape of the base, pyramids may be called triangular pyramids, square pyramids, pentagonal pyramids, and so on. A triangular pyramid is also known as a **tetrahedron**.

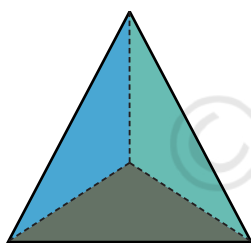

Triangular
Pyramid

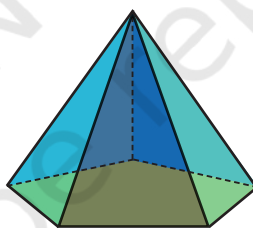

Pentagonal
Pyramid

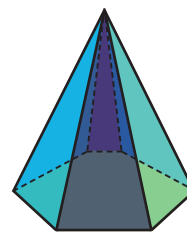

Hexagonal
Pyramid

- ? If the congruent polygons of a prism have 10 sides, how many faces, edges and vertices does the prism have? What if the polygons have n sides?
- ? If the base of a pyramid has 10 sides, how many faces, edges and vertices does the pyramid have? What if the base is an n -sided polygon?

Now we will see how to make different solids using a foldable flat surface such as paper, cardboard, etc.

The basic idea is to create a shape on a flat surface that can be folded into the solid. Such a shape is called a **net**. In other words, a net is obtained by ‘unfolding’ a solid onto a plane.

? What is a net of a cube?

Fig. 4.1 is a net of a cube.

? Visualise how it can be folded to form a cube.

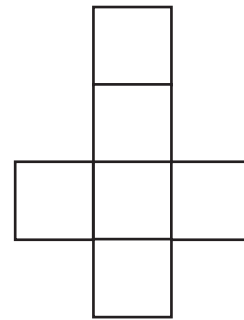
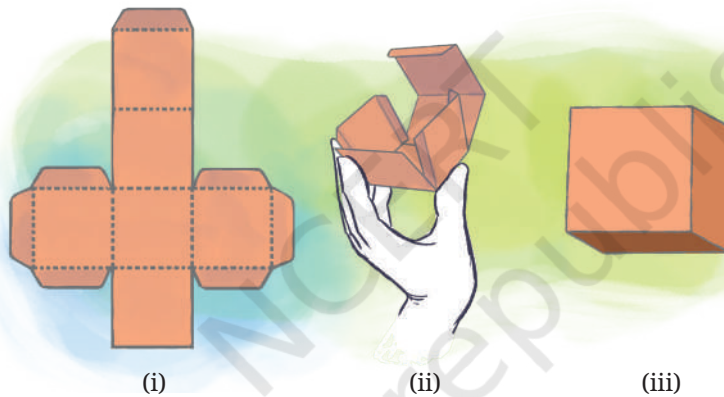

Fig. 4.1

Practical Aspects of Using a Net

To make an actual cube from its net, certain practical aspects have to be kept in mind. One is that the material used must have sufficient sturdiness for the cube to stand. The second aspect is that there should be some mechanism for attaching the faces together. If cardboard or a similar material is used, cello tape is one way to join the adjacent faces. For less sturdy materials, such as chart paper, it is useful to have extra ‘flaps’ on some of the faces that can be stuck to the adjacent faces. You might have observed this strategy in packaging boxes.



However, when we talk about the net of a solid, we consider only the shape formed by unfolding the solid, and not the other supporting flaps that we may use to actually make the solid.

Apart from using a net, there are other ways to make a cube from paper.

There are multiple possible nets one can use to build a cube.

? Figure it Out

1. Which of the following are the nets of a cube? First, try to answer by visualisation. Then, you may use cutouts and try.

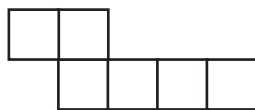

(i)

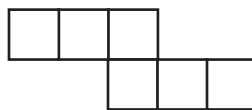

(ii)

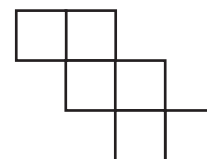

(iii)

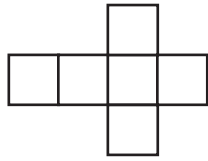

(iv)

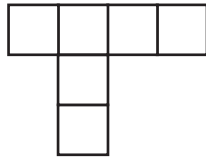

(v)

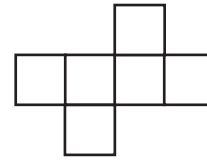

(vi)

2. A cube has 11 possible net structures in total. In this count, two nets are considered the same if one can be obtained from the other by a rotation or a flip. For example, the following nets are all considered the same —

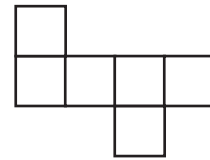
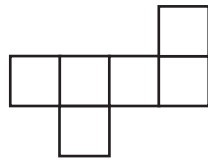
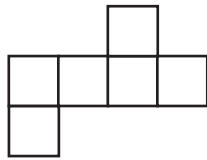

Find all the 11 nets of a cube.

3. Draw a net of a cuboid having sidelengths:

- (i) 5 cm, 3 cm, and 1 cm
- (ii) 6 cm, 3 cm, and 2 cm

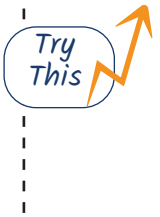

Let us find out the nets of other solids.

A tetrahedron whose faces are equilateral triangles is called a regular **tetrahedron**.

- ? What is a net of a regular tetrahedron? Which of the following are nets of a regular tetrahedron?

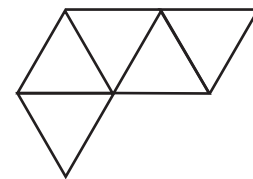
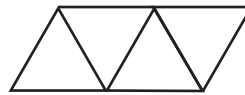
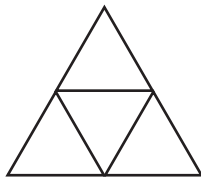

- ? Are there any other possible nets?

A regular tetrahedron has only 2 possible nets.

- ? Draw a net with appropriate measurements that can be folded into a regular tetrahedron. Verify if it works by making an actual cutout.

- ? Draw a net with appropriate measurements that can be folded into a square pyramid. Verify if it works by making an actual cutout.



? What is the net of a cylinder?

If the circular faces of a cylinder are unfolded, and if a cut is made along the height of the cylinder, as shown in the figure below, then we get

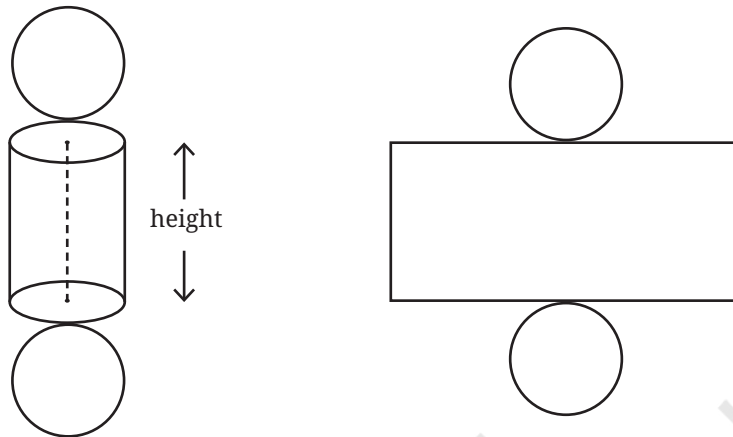

? What are the sidelengths of the rectangle obtained?

? How will the net of a cone look?



? If the cone is slit open along the line l and then unrolled, what will we get?

Observe that all the points on the boundary of the base circle are at equal distances from 'O'. So after unrolling the cone, the boundary of the net will be a portion of a circle with centre O.



? What surface do you construct by using the above net, in which O is not the centre of the boundary circle? Make a physical model to help you answer this question!

? Draw a net with appropriate measurements that can be folded into a triangular prism. Verify that it works by making an actual cutout.

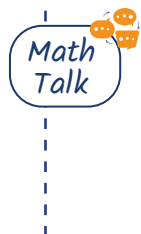

Here is a solid called the **octahedron**, made by joining two square pyramids at their square bases.

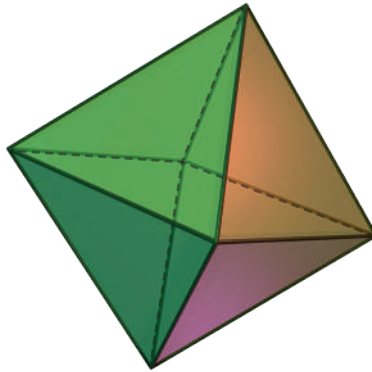

Octahedron

Can you visualise its net? This is one of its nets.

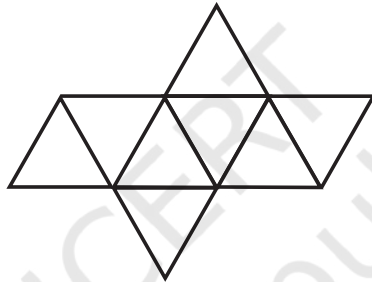

- ? Taking all the triangles in the net to be equilateral, make a cutout of the net and fold it to form an octahedron.



As in the case of cubes, an octahedron too has 11 different nets.

So far, we have seen solids whose faces are all equilateral triangles (regular tetrahedrons), and all squares (cubes). Does there exist a solid whose faces are all pentagons? Interestingly, the answer is yes!

This solid is called a **dodecahedron**. This solid too can be made from a net! Mathematicians have been even able to determine exactly how many nets a dodecahedron has — 43,380.

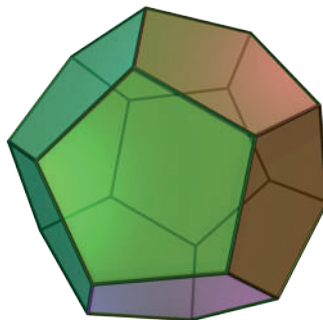

Dodecahedron

- ? **Net of a sphere?** Experiment and see if you can make a paper cutout that can perfectly wrap around a ball without leaving any wrinkles, gaps or overlaps.

Shortest Paths on a Cube

Let us consider an interesting problem related to the discussion so far. We know that on a plane, the shortest path between two points is the straight line between them. Now, what is the shortest path between two points on the surface of a cuboid, if we are allowed to travel only along its surface?

Let us imagine a hungry ant living on the surface of a cuboid. To its good fortune, there is a laddu on the surface.

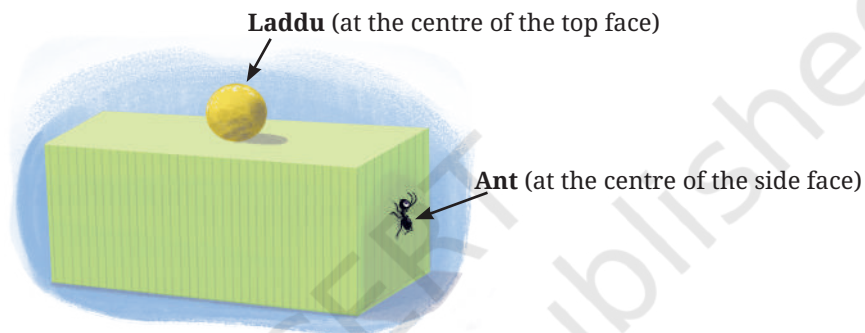

- ? What is the shortest path for the ant to reach the laddu?
- ? What about in the following case?

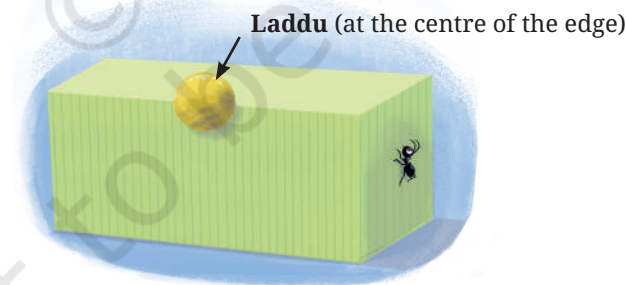

- ? If we think that a certain path is the shortest, how can we be sure that it truly is, among all the infinite possibilities?
- ? For example, are either of these the shortest path?

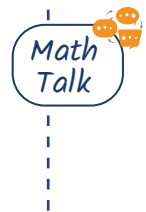
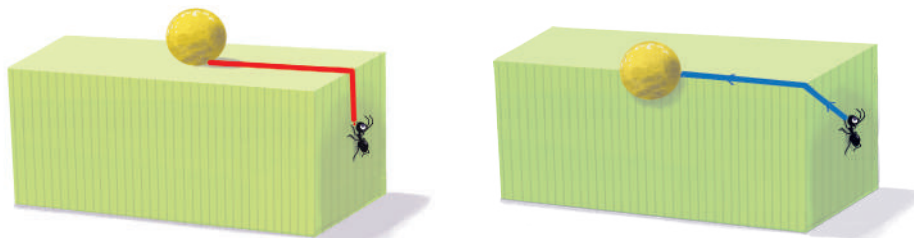

[Hint: Draw the net and see how these paths appear on the net.]

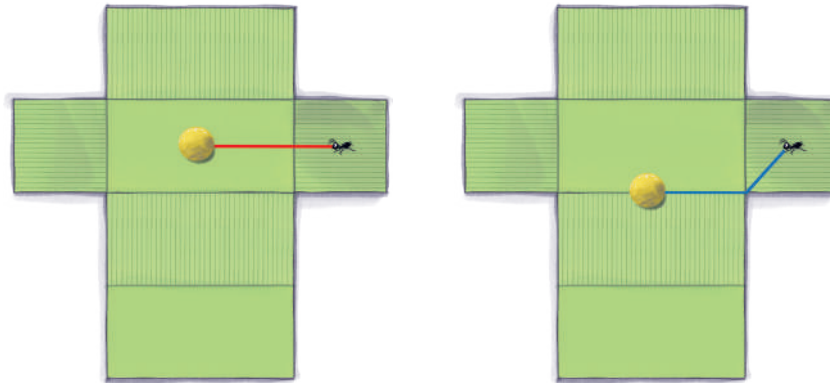

? What does this show?

A path on the surface of the cuboid can be transformed to a path of the same length on the net. Conversely, every path on the net transforms to a path of the same length on the cuboid.

In the first case, the path marked on the cuboid is the shortest since it transforms to a straight line between the ant and laddu on the net, which is the shortest path between them.

In the second case, the path marked on the cuboid does not transform to a straight line path on the net, and hence is not the shortest path for the ant to take.

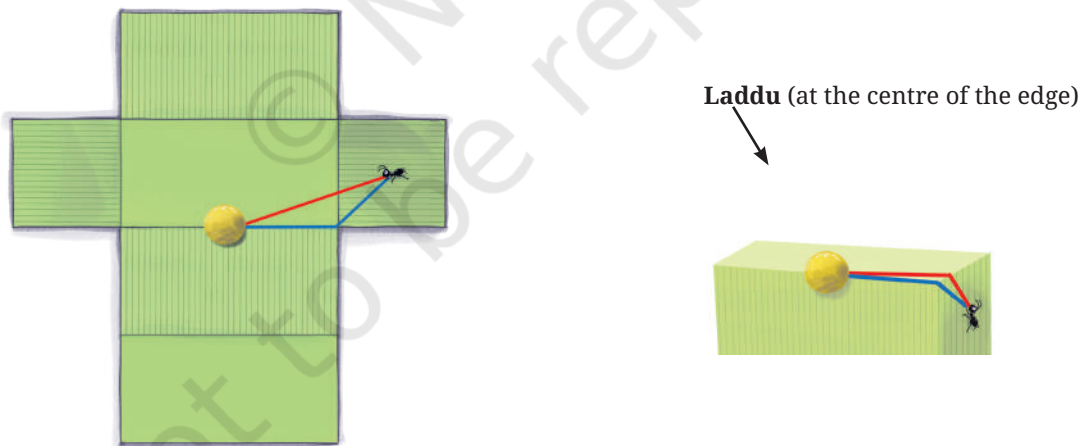

The red path is the shortest

Thus, by using a net, we convert the problem of finding the shortest path on a cuboid to the problem of finding the shortest path on the net.

Have we now completely analysed the problem of finding the shortest path between two points on a cuboid?

- ? Find the shortest path between the ant and the laddu in the following case:

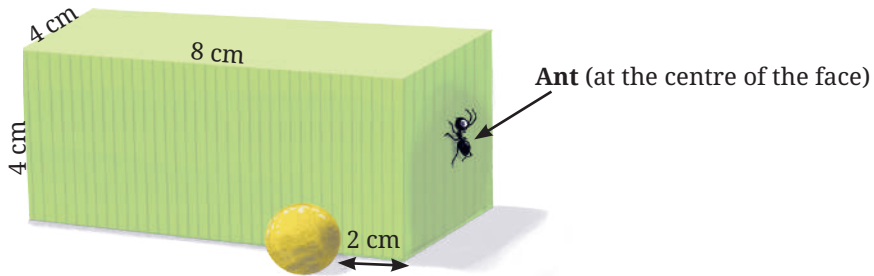

If we unfold the cuboid as before, we get

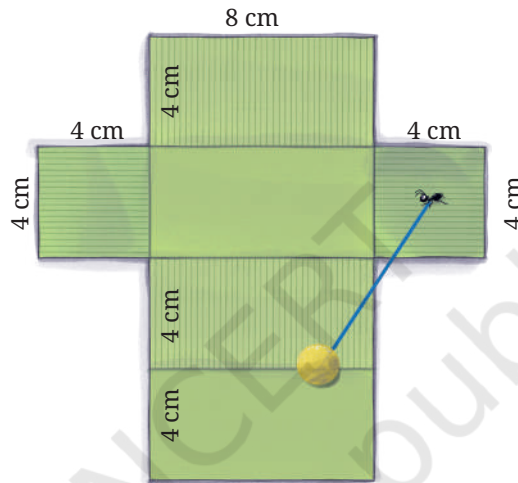

Notice the line segment between the ant and laddu going outside the net! Obviously, this does not correspond to any path on the cuboid.

- ? So what do we do now?

If the net is unfolded in the following way, then we get a path on the cuboid.

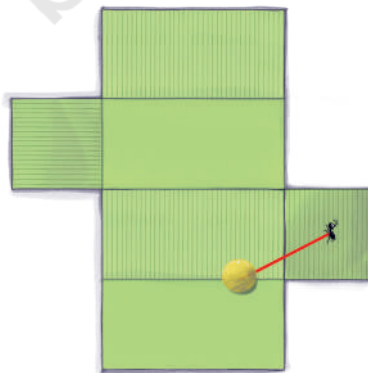

The shortest path

Thus, the way a cuboid is unfolded matters!

Now we will look at a trickier case.

? What is the length of the shortest path between the ant and the laddu?

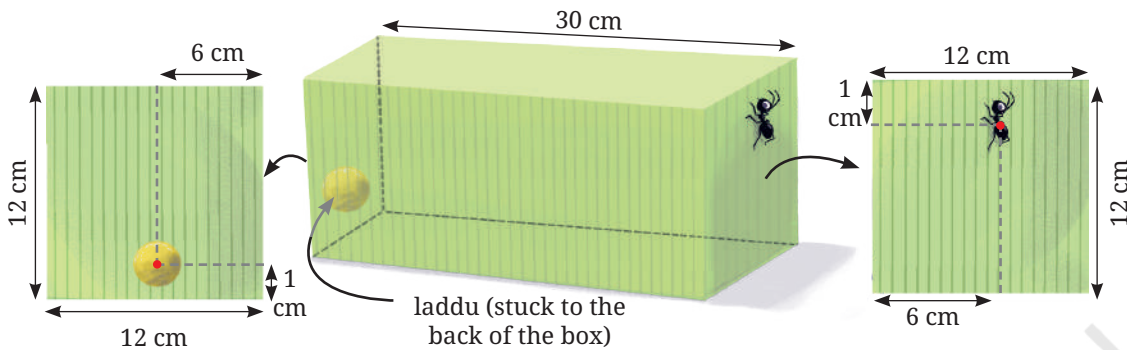

Here are some of the ways of unfolding the cuboid.

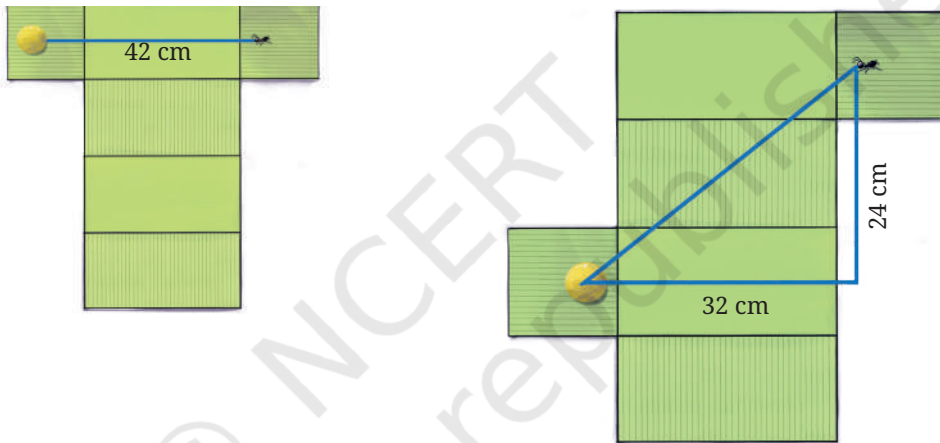

In the second case, the distance d between the ant and the laddu can be calculated using the Baudhayana Theorem, since we have a right triangle here.

$$d^2 = 24^2 + 32^2$$

$$d = \sqrt{1600} = 40 \text{ cm}$$

We see that in each of these unfoldings, the lengths of the line segments between the ant and the laddu are different! So we have to carefully list all the possible different unfoldings to find the answer!

Representation of Solids on a Plane Surface

Drawing is one of the oldest human activities. People have been doing it for thousands of years for both aesthetic as well as practical and engineering purposes. Regarding the latter, making a drawing of an object is a useful way to record or convey information about it. Visual representation also helps us in thinking about the objects being represented. Such needs often arise in engineering — while constructing buildings, designing machines, etc. Further, engineering drawings need

to be detailed enough so that one can physically construct the objects they depict.

We will now explore some ways of drawing solids on a plane.

Projections

The net of a solid (when it exists) is one way of representing a solid on the plane. But it can be difficult to visualise the solid from the net, without physically cutting out the net and folding it up.

Another way to represent a solid is by looking at the **projections** of all its points on a plane. This idea is closely related to the profile of a solid from a specific viewpoint, which we discussed earlier. Let us see how this technique works.

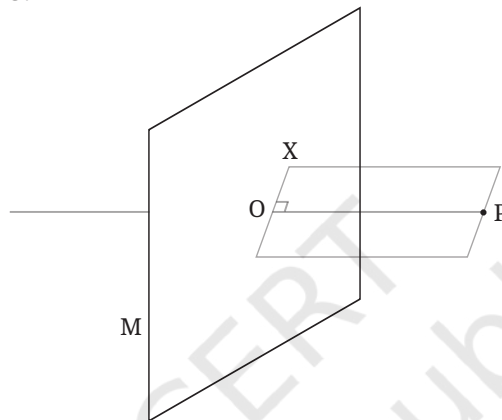

O is the projection of P

Consider a point P in space, and a plane M. Imagine a line from P intersecting the plane M at a point O.

We say that OP is **perpendicular to the plane** if for any line OX on the plane, $\angle POX = 90^\circ$. In this case, we say that point O is the **projection** of point P on the plane. The projections of all the points of an object together form the **projection of the object on the plane**.

? Let us visualise the projection of a line.

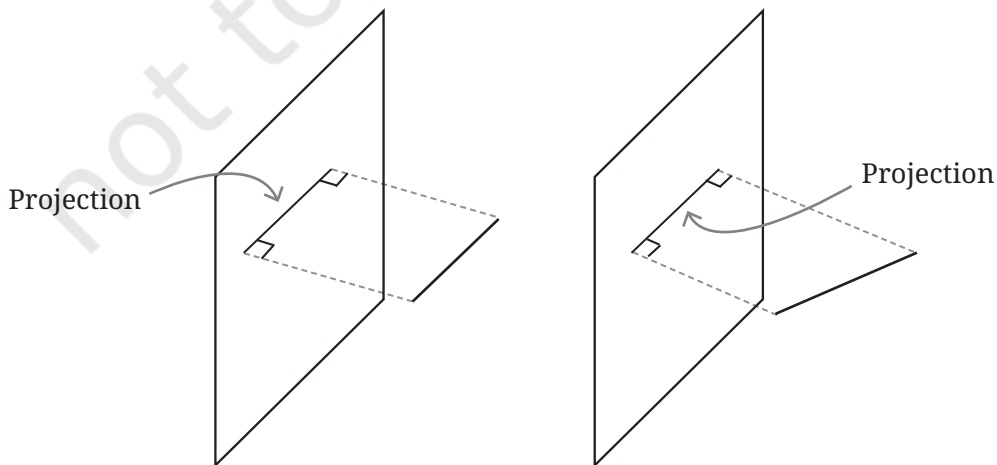

Fig. 4.2

? What happens to the length of a line in its projection?

Let us consider projections in Fig. 4.3. For example let l be the actual length of the line and p be the length of its projection.

Draw $AE \perp BC$. $AECD$ is a rectangle (why?). So, $AE = DC = p$. Also, $\angle AEB = 90^\circ$.

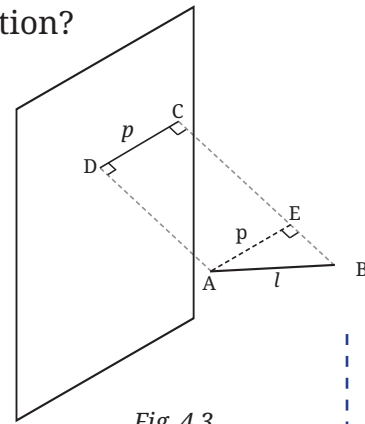

Fig. 4.3

? Can you now compare the lengths p and l ?

? When is the length of the projected line equal to its actual length?

? What do you think are the different possible projections of a square that we get based on its orientation?

? What do you think is the projection of a parallelogram under different orientations?

Can this ever be a quadrilateral that is not a parallelogram? As a starting point, you could think about the projection of a pair of parallel lines.

? What can you say about the projection of an n -sided regular polygon? [Hint: Projection of a polygon is composed of the projections of its sides.]

Let us consider projections of solids now.

? How would the projections of a cube and a cone look?

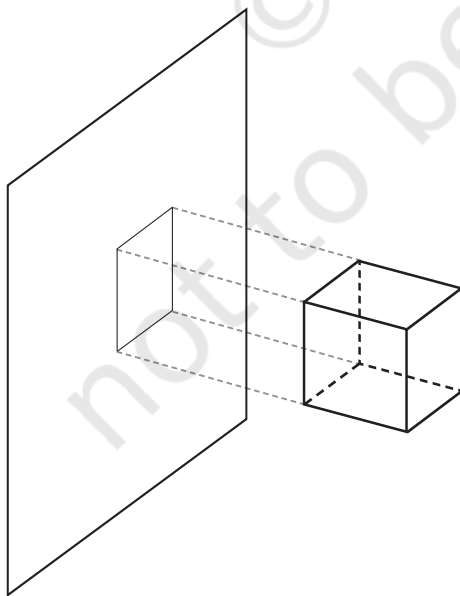

Fig. 4.4

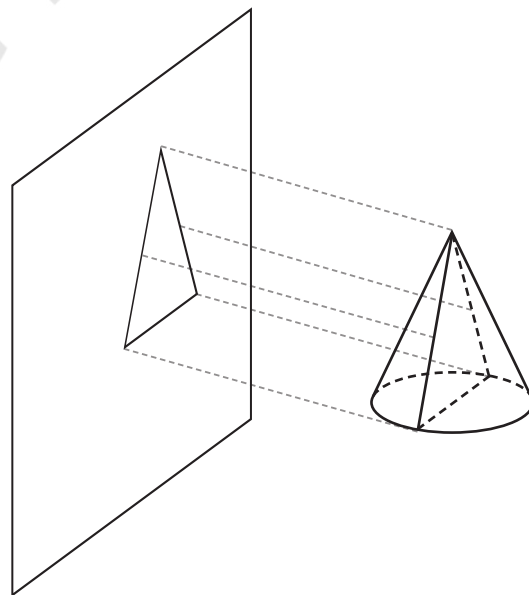

Fig. 4.5



If an object were to pass perpendicularly through a plane and form a hole, the shape of the hole would be the same as the shape of the projection of the object.

- ? See Figures 4.2–4.5. In each case, see if you can visualise another object that gives the same projection.

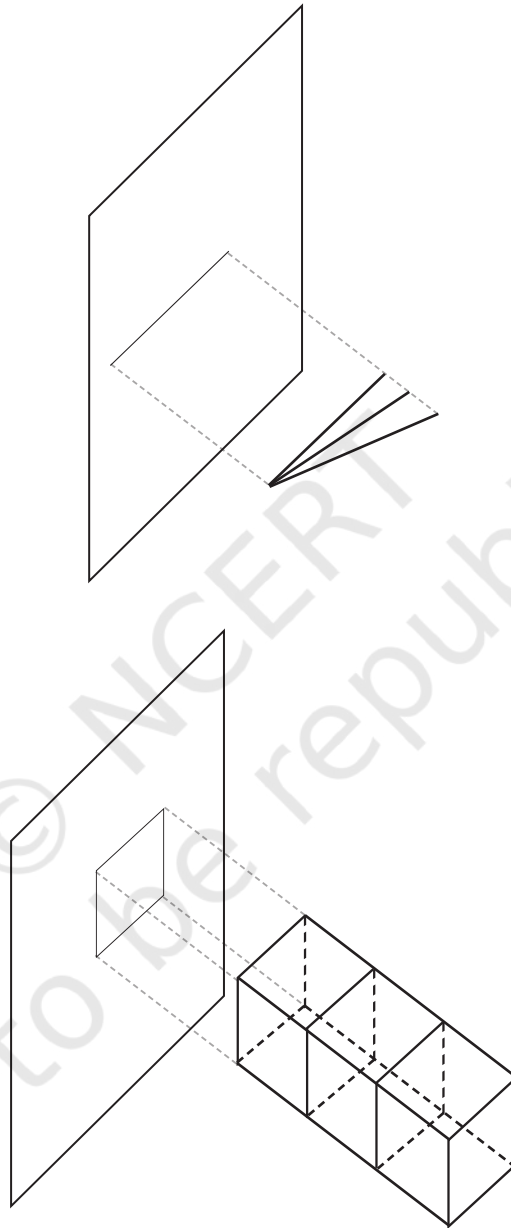

Fig. 4.6

Different lines and different cuboids giving the same projections

We see that a given projection is not made by a unique object.

- ? Find another object that makes the same projection as that of a given cone.

For this reason, we often take three mutually perpendicular projections of an object. As shown in the figure, we consider a plane in front of the object called the **vertical plane**, a plane below the object called the **horizontal plane** and a plane to the side of the object called the **side plane**.

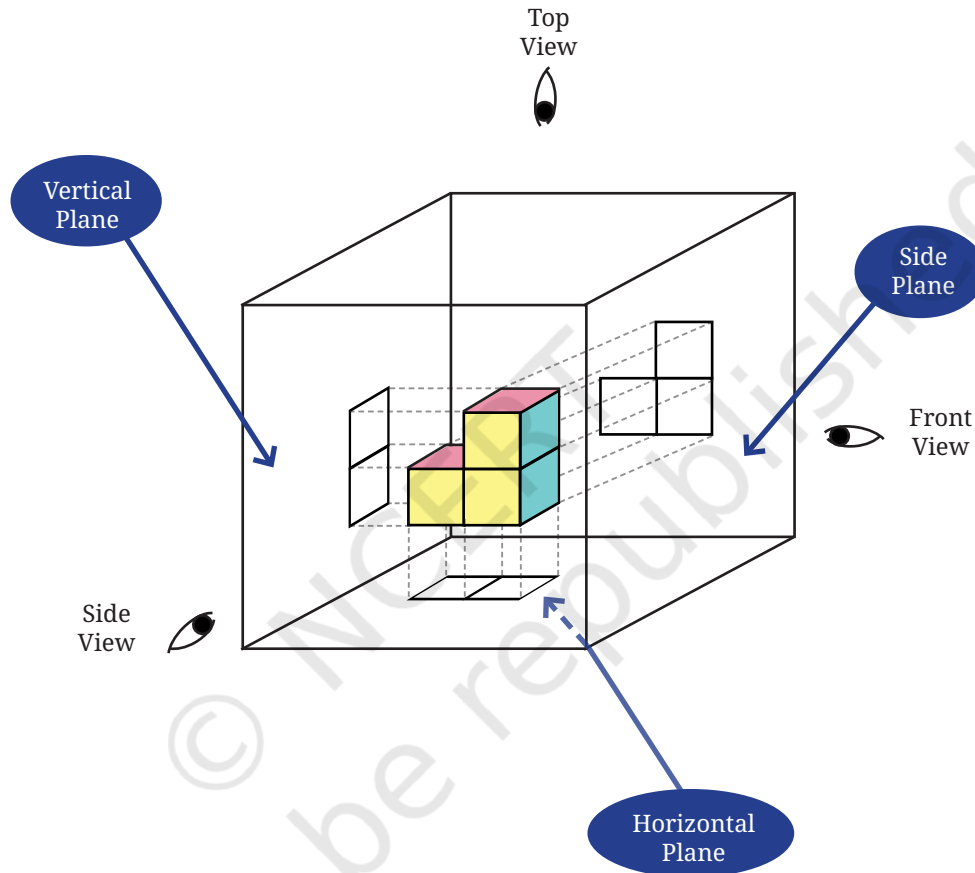

We give names to the projections on these three planes based on the directions from which the object is viewed. The projection on the vertical plane is called the **front view**, on the horizontal plane the **top view** and on the side plane the **side view**. These projections formalise the notion of profiles that we explored in an earlier section.

- ? Let us see what these projections are for the objects shown in Fig. 4.6, when the planes shown are taken to be vertical planes.
Projections of the different lines in Fig. 4.6 —

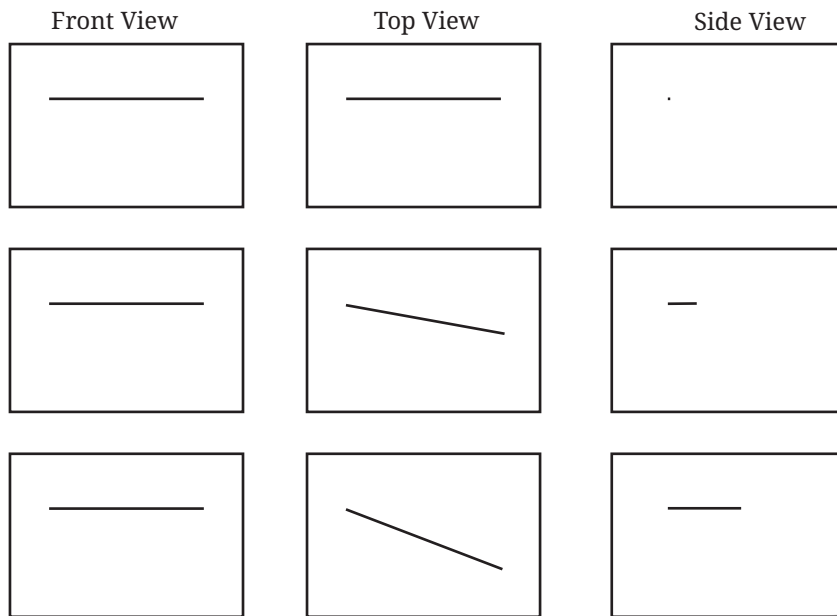

Projections of the different cuboids in Fig. 4.6 —

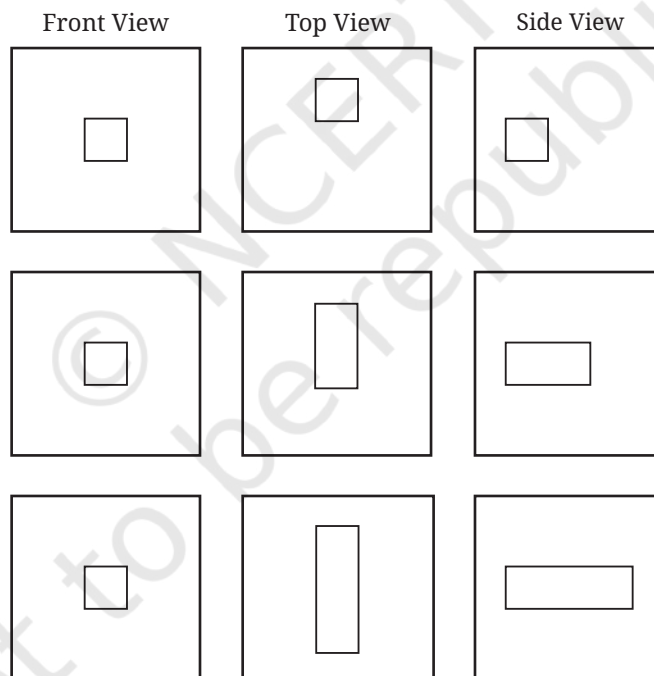

? Figure it Out

1. Observe the front view, top view and side view of the different lines in Fig. 4.6. Is there any relation between their lengths?
2. Find the front view, top view and side view of each of the following solids, fixing its orientation with respect to the vertical, horizontal and side planes: cube, cuboid, parallelepiped, cylinder, cone, prism, and pyramid. If needed, see the next problem for clues.



3. Match each of the following objects with its projections.

	FRONT	TOP	SIDE

Shadows

Place an object in front of a plane, such as a wall of your room. Shine a torch light on the object in a direction perpendicular to the wall.

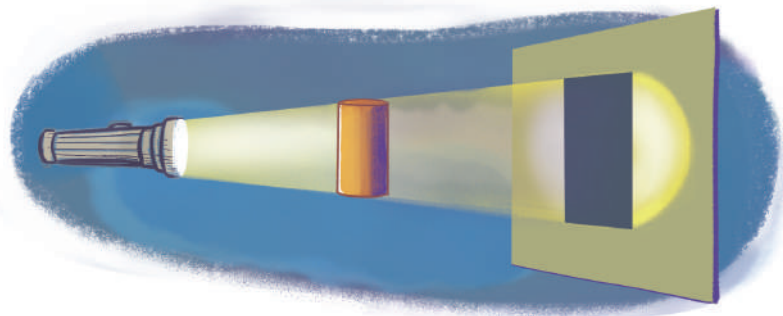

? What do you see?

We will see that the shape of the shadow on a plane is quite similar to the shape of the projection on that plane! However the shadow may be scaled up, stretched, or even distorted slightly, depending on how the object is held.

? Observe what happens to the size of the shadow as you vary the distance between your torch and your object.

? Why does this happen?

Now, imagine your torch is extremely powerful and will continue casting a shadow of the object on the wall, no matter how far back you move it.

If this imaginary torch always points in a direction perpendicular to the wall, then, as the distance between the torch and the object increases, the shadow of the object will become indistinguishable from the projection of the object to the wall plane!

Although this experiment may sound fanciful, you have encountered one such extremely powerful and distant torch before...namely, the Sun! Indeed, when sunlight is perpendicular to a plane, the shadows it casts on that plane are indistinguishable from projections!

Earlier we asked what the projection of a parallelogram might look like. You can now physically answer this question by making a cutout of a parallelogram and viewing its shadows under sunlight. No matter how you orient the parallelogram, you will see that the shadow remains a parallelogram!

More generally, the projection of a pair of parallel lines will always remain parallel.







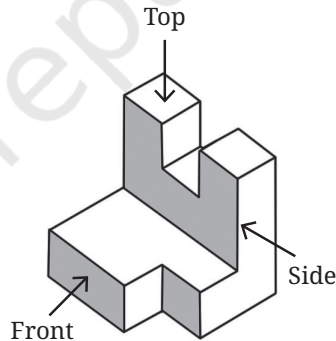
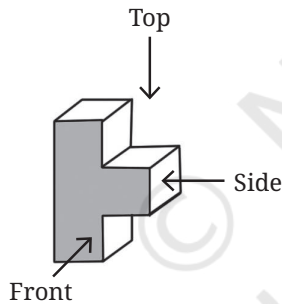
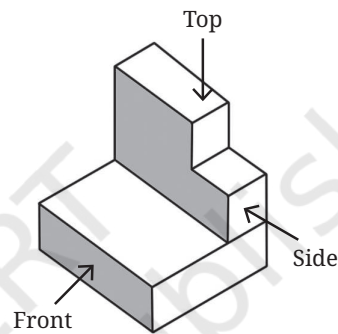
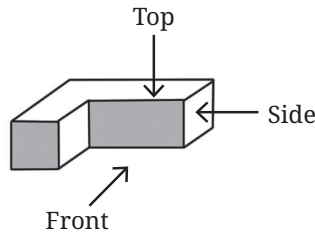
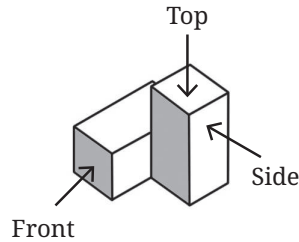
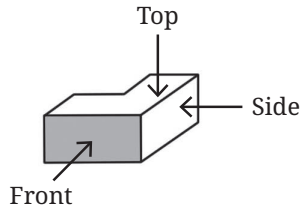

This property is useful for drawing projections of objects.

? Figure it Out

1. Draw the top view, front view and the side view of each of the following combinations of identical cubes.



2. Imagine eight identical cubes, glued together along faces to form the letter 'E'.

- (i) This looks like a  from the front. What does it look like from the side? From the top?
- (ii) Glue additional cubes to make a shape that looks like  from the front and  from the top.
- (iii) Now, can you glue even more cubes to make it look like  from the front,  from the top, and  from the side?
- (iv) Can you think of other letter combinations to make with a single combination of cubes in this manner?

Math Talk

3. Which solid corresponds to the given top view, front view, and side view?

Front View

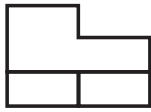

Top View

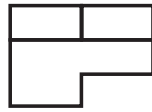

Side View

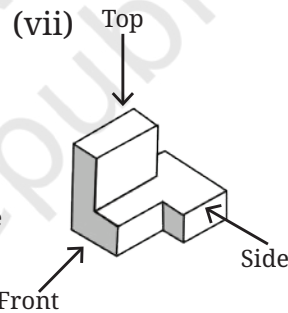
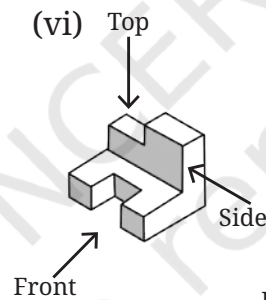
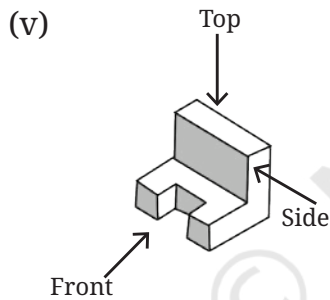
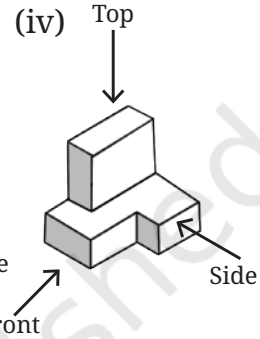
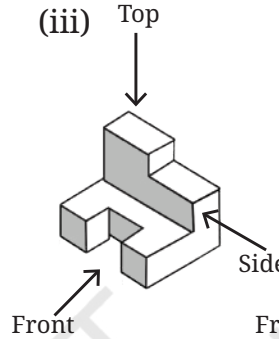
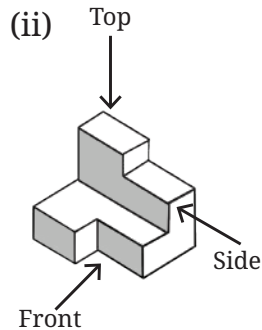
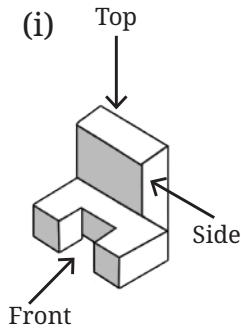
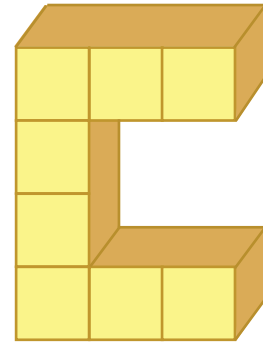
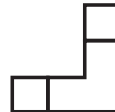

4. Using identical cubes, make a solid that gives the following projections.

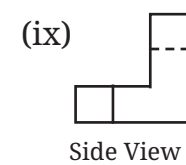
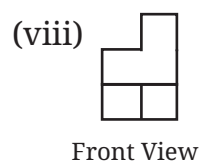
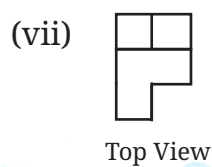
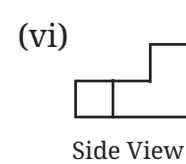
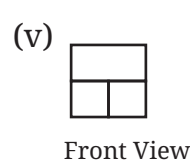
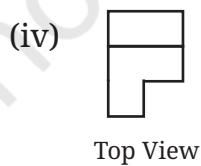
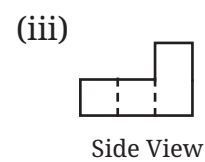
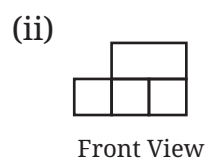
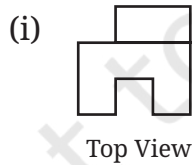

5. Find the number of cubes in this stack of identical cubes.

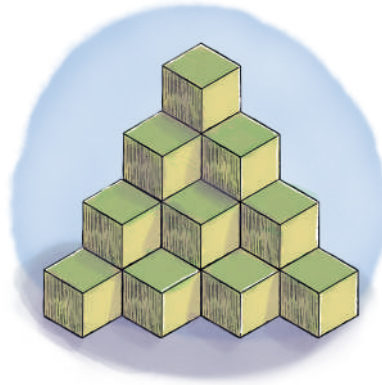

6. What are the different shapes the projection of a cube can make under different orientations?



Isometric Projections

In general we lose information when projecting a solid to a plane. But depending on the orientation of the solid, we can sometimes recover much of the information we've lost.

Let us consider an orientation of a cube in which the lengths of the projections of all the edges of the cube are equal. Such a projection is called the **isometric** projection of the cube. 'Isometric' means 'equal measure' in Greek.

Imagine balancing a cube perfectly on one of its corner vertices, and then projecting it down to the floor plane. This projection is isometric and appears as shown.

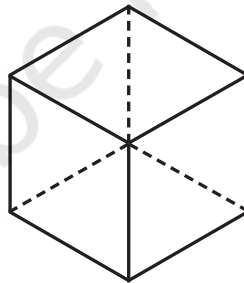

- ? Construct a model of a cube and use your hands to keep it balanced on one corner vertex. Can you try to understand why all the projected edges have equal length?



The isometric representation of a cube is a regular hexagon. If the cube is made of glass, then all the edges would be visible.

This structure is the basis for **isometric** drawing! Tile the plane with hexagons and we get an **isometric grid**.

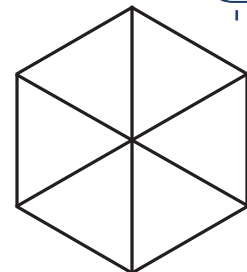

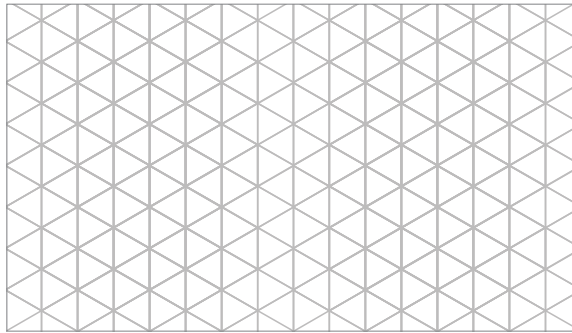

Isometric grids are widely used in engineering. They make it easy to draw projections of solids and to measure lengths along all the 3 primary directions — length, depth and height, as shown in Fig. 4.7.

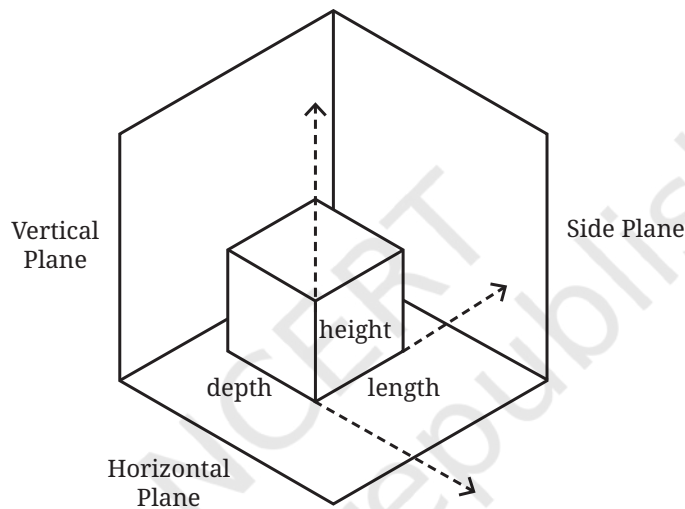

Fig. 4.7

Drawing on Isometric Grids

? Have you played Tetris? There are five basic shapes in Tetris, corresponding to the different ways of arranging four squares.

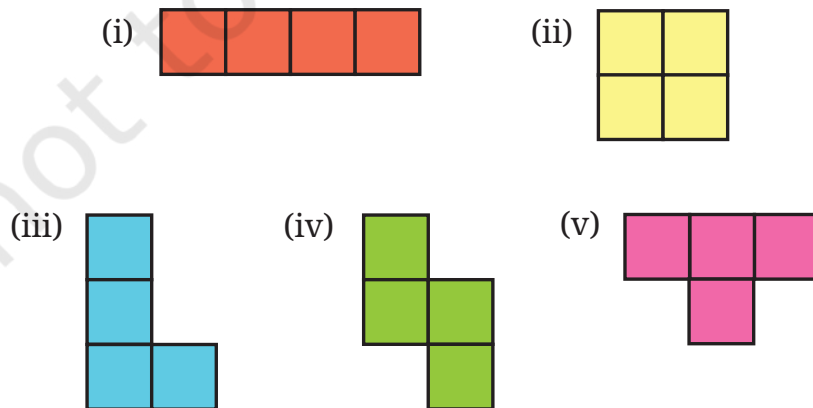
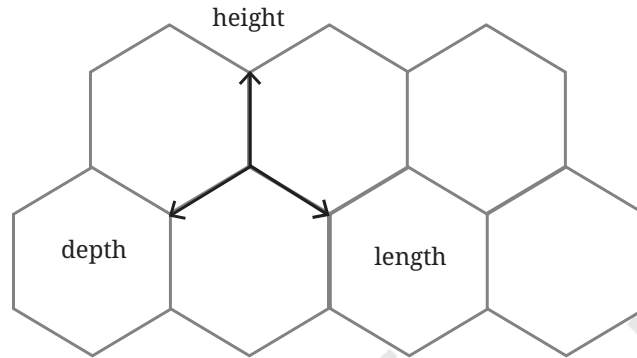

Fig. 4.8

? Imagine these are cubes, not squares. Draw each of these on your isometric paper (you can find it at the end of the book).

As seen in Fig. 4.7, there are three principal axes of the solid shape, which we will call the depth axis, length axis, and height axis.

The edges of the grid appear in three different orientations: /, \ and |. We will associate height to |, depth to /, and length to \.



While drawing on the grid, it may be useful to draw edge by edge, counting the number of units you want to go along a given axis.

For example, you can draw a $1 \times 1 \times 1$ cube as follows. How would you draw a $2 \times 2 \times 2$ cube? Feel free to add shading, if it helps you visualise the solid.

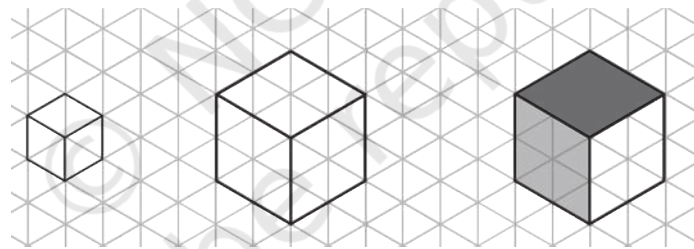

The first tetris shape is a row of four cubes joined face-to-face. In order to draw this solid, you will need to choose an orientation for the row of four cubes.

Let's draw it oriented along the depth axis. You could draw it cube-by-cube, but in that case you may need to erase the lines that get hidden by additional cubes. (If you don't have an eraser, you can also draw faint lines initially, and then darken the visible ones later.)

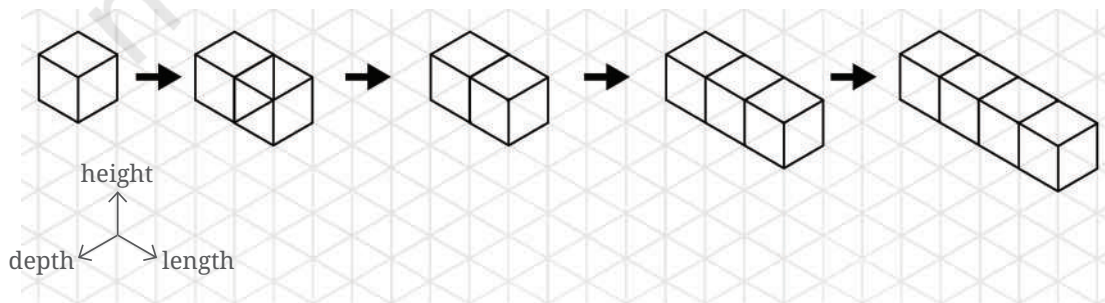

You could also draw it all at once, by counting edges as you go:

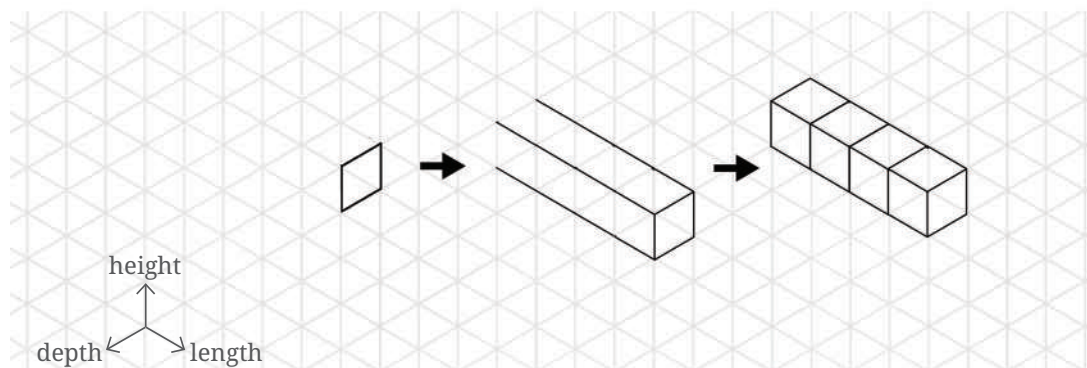

Similarly, you could draw the shape oriented along the height axis or the length axis.

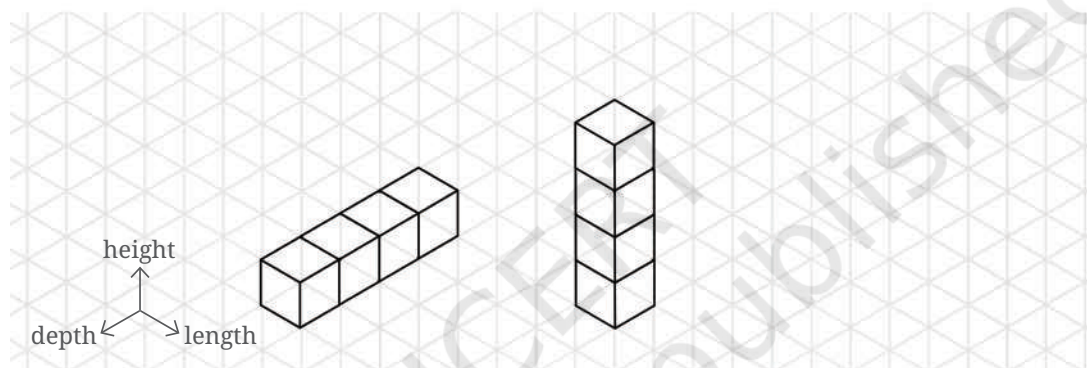

In your drawing, moving in the vertical direction on the isometric paper corresponds to moving along the height axis of the solid. Similarly, moving along the \ or / direction on the paper corresponds to moving along the length or depth axis respectively of the solid.

? Why is this correspondence between directions on isometric paper and axes of the solid so effective for communicating the shape of the solid?

Earlier we observed that parallel lines project to parallel lines. This geometric fact ensures that the three families of parallel edges on the solid (corresponding to height, the length, and depth) project to three families of parallel edges on the isometric paper: |, /, and \. Moreover, the isometric nature of the projection ensures that the projections of unit distances along the three axes are equal.

Can you try drawing the other tetris shapes on isometric paper?

? **Figure it Out**

1. In addition to the 5 ways shown in Fig. 4.8, are there any additional ways of gluing four cubes together along faces? Can you visualise and draw these as well?



- (ii) Recreate this on an isometric grid.
- (iii) Why does the illusion work?



SUMMARY

- Fractals are self-similar geometric objects found in nature and in art.
- The Sierpinski Carpet, Sierpinski Gasket, and Koch Snowflake are some examples of mathematical fractals. They can be obtained by repeatedly applying certain geometric operations that generate a sequence of shapes approaching the fractal.
- Cuboids, tetrahedrons, cylinders, cones, prisms, pyramids, and octahedrons are some of the solids that can be obtained by folding suitable **nets**.
- The shortest path between two points on the surface of a cuboid can be found by using a suitable net of the cuboid.
- Any object can be represented on a plane surface by using its **projections** on plane surfaces. For this purpose, we generally use the **front view** (projection on the **vertical plane**), **top view** (projection on the **horizontal plane**), and **side view** (projection on the **side plane**) of the object.
- A cube can be oriented such that the lengths of all its edges in the projection are equal. Such a projection is called the **isometric projection**. Isometric projections of different solids can be drawn using isometric grid paper.

5

TALES BY DOTS AND LINES



5.1 The Balancing Act

Last year, we learnt about the mean and median. Recall that the mean of some data is the sum of all the values divided by the number of values in the data. The median is the middle value when the data is sorted.

We shall try to understand the mean and median from a different perspective and see how the mean behaves with changing data.

- ❓ Consider any 2 numbers. Find their average/arithmetic mean. Repeat this by taking other pairs. What do you observe?

For example, let the two numbers be 3 and 7. Their average is $\frac{3+7}{2} = 5$. Taking another pair of numbers, say 8 and 9, their average is $\frac{8+9}{2} = 8.5$. Visualising these as dot plots we get

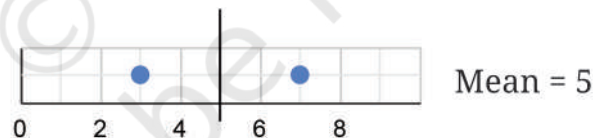

Notice that the mean is exactly halfway between the two numbers.

We have learnt earlier that the arithmetic mean is a measure of central tendency and represents the 'centre' of the data. Let us see how the mean represents the 'centre' in the case of 3 numbers.

- ❓ Calculate and mark the mean of each collection of data below.

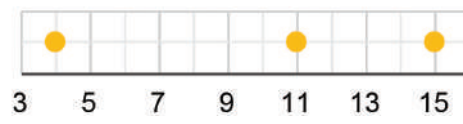
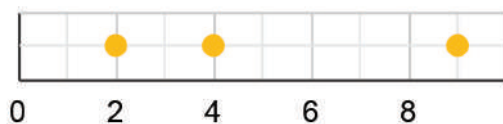
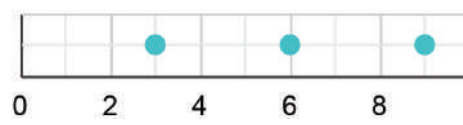
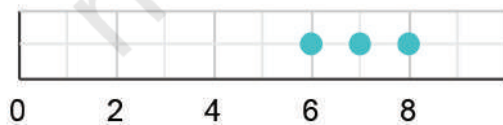



- Can you explain how the mean is the centre of each collection?
- Mark the mean for the collections below.

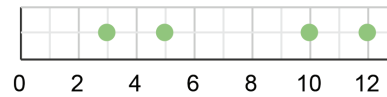
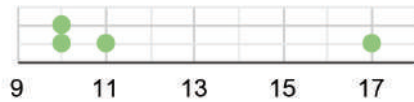
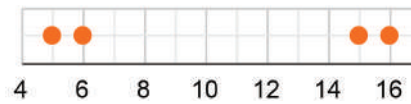

- Can you explain how the mean is the centre of each collection?

Is the mean the midpoint of the two endpoints/extremes of the data? It is not always so. Instead, the total distances are equal on both the sides of the mean. This is illustrated through the following dot plots.

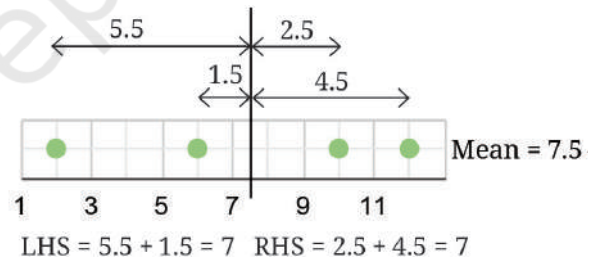
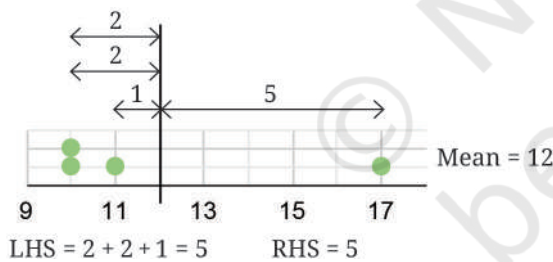
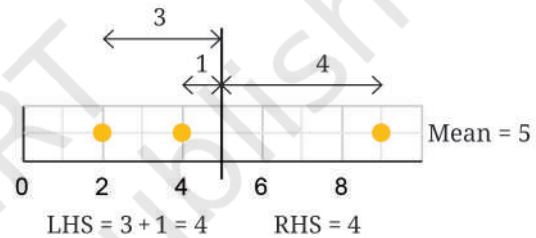
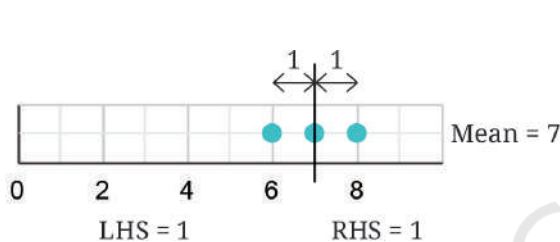

- Verify that this holds for all the collections of data shown earlier.
- Can there be more than one such 'centre'? In other words, is there any other value such that the sum of the distances to the values lower than it and the values higher than it will still be equal?
- In the case of the collection 10, 10, 11, and 17 whose mean is 12, suppose there is a different centre larger than 12.

Clearly, all the distances on the LHS will increase and the distances on the RHS will decrease. Thus, it is no longer the 'centre'. Similarly, for any value smaller than 12, the distances on the LHS will decrease while those on the RHS will increase.

Both these cases are illustrated in the following diagram. Therefore, there is only one centre.

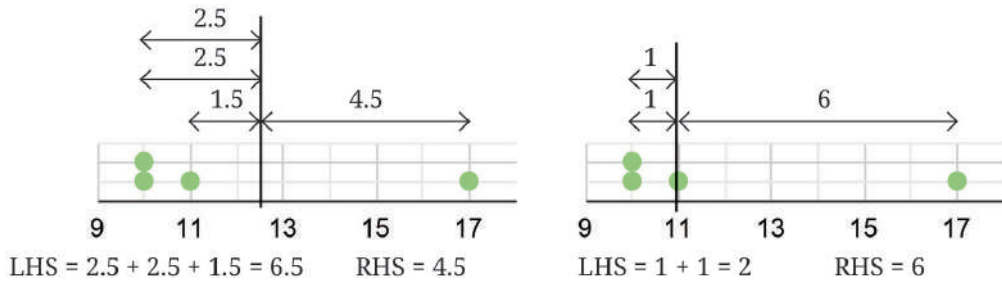

? Will including a new value in the data increase or decrease the mean?

When a new value greater than the mean is included, the mean increases to maintain the balance between the sum of distances on the LHS and RHS, as illustrated below.

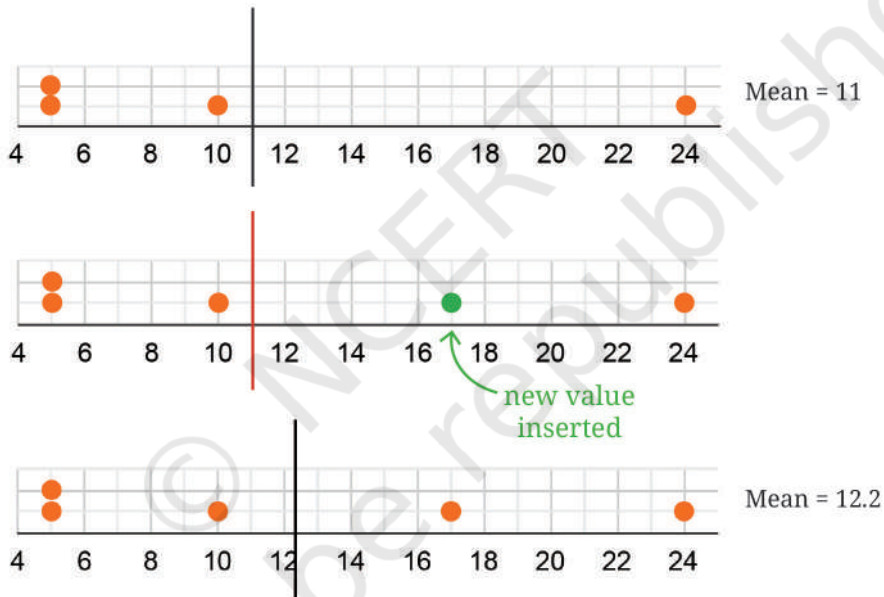

Similarly, if a value smaller than the mean is included, then the new mean will be less than before.

? What happens to the mean when an existing value is removed? When will the mean increase, decrease, or stay the same?

? What happens to the mean if a value equal to the mean is included or removed?

Try to explain this using the fair-share interpretation of mean that we studied last year.



Unchanging Mean!

We saw earlier how the mean varies when a value is included or removed.

- Explore if it is possible to include or remove 2 values such that the mean is unchanged.

You may use the following data to experiment with.

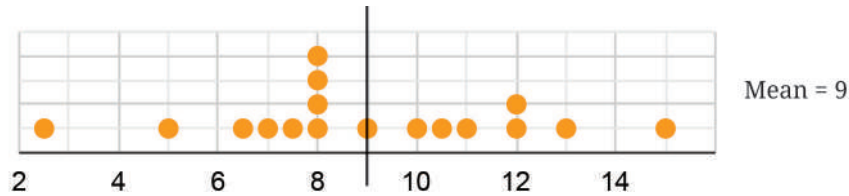

- How about including or removing 3 values without changing the mean? Is it possible?
- Can we include 2 values less than the mean and 1 value greater than the mean, so that the mean remains the same?

One of the possibilities is shown here.

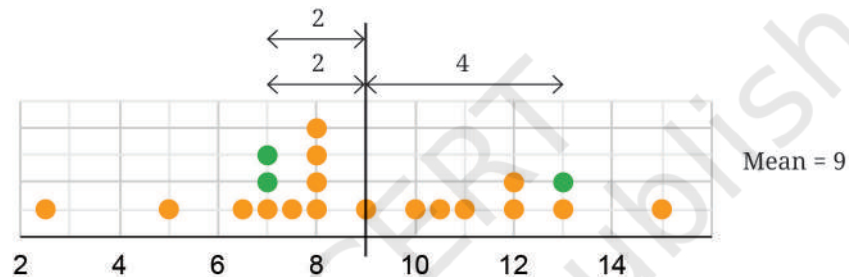

- Try to include 2 values greater than the mean and 1 value less than the mean, so that the mean stays the same.

Relatively Unchanged!

- We saw what happens to the mean when values are included or removed from the collection. What happens to the mean if every value in the collection increases by some fixed number?
- Consider the data: 8, 3, 10, 13, 4, 6, 7, 7, 8, 8, 5. Calculate its mean.
- Now, consider this data with every value increased by 10: 18, 13, 20, 23, 14, 16, 17, 17, 18, 18, 15. What is its mean? Is there a quicker way to find out?

[Hint: Observe the following dot plots corresponding to the two data collections.]

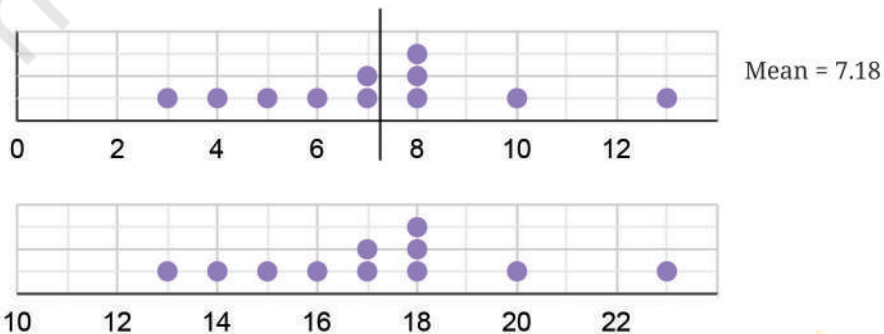

The mean of the new collection also increases by 10. Notice that the relative position of the mean stays the same.

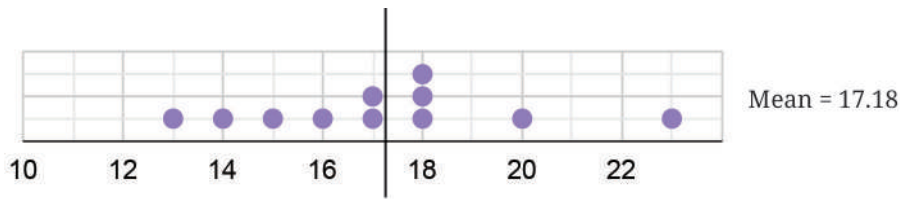

We get the following dot plot if we reduce every value by 1.

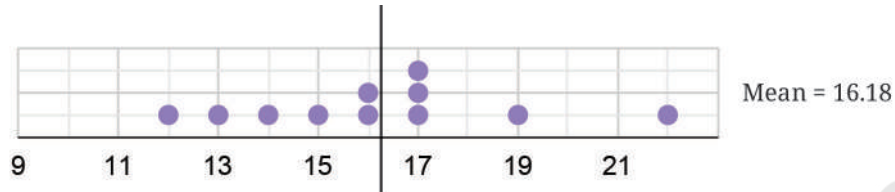

This can be explained using algebra —

Suppose there are n values in the collection. Let these values be represented by $x_1, x_2, x_3, \dots, x_n$. Their average is given by —

$$\frac{x_1 + x_2 + x_3 + \dots + x_n}{n} = a.$$

When a fixed number, for example, 3 is added to every value in the collection, the new average becomes —

$$\begin{aligned} & \frac{(x_1 + 3) + (x_2 + 3) + (x_3 + 3) + \dots + (x_n + 3)}{n} \\ &= \frac{x_1 + x_2 + x_3 + \dots + x_n + 3n}{n} \\ &= \frac{x_1 + x_2 + x_3 + \dots + x_n}{n} + \frac{3n}{n} \\ &= a + 3. \end{aligned}$$

That is, the new average is 3 more than the previous average.

- ① Try to explain, using algebra, what the average is when a fixed number, e.g., 2 is subtracted from every value in the collection.
- ① Try to explain this using the fair-share interpretation of average that you learnt last year.
- ① What happens to the average if every value in the collection is doubled?



You may have guessed that the average also doubles. The following is an example with the data we saw earlier —

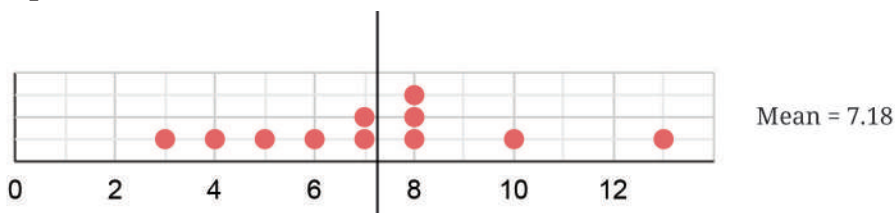

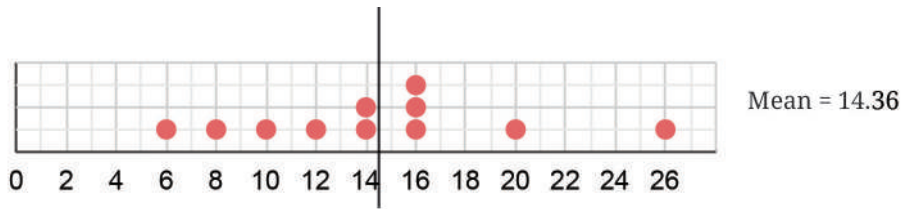

We can see that the average has doubled.

Let us prove it using algebra.

Suppose there are n values in the collection. Let these values be represented by $x_1, x_2, x_3, \dots, x_n$. Their average is —

$$\frac{x_1 + x_2 + x_3 + \dots + x_n}{n} = a.$$

When a fixed number, for example, 5 is multiplied to every value in the collection, the new average becomes —

$$\begin{aligned} & \frac{(5x_1) + (5x_2) + (5x_3) + \dots + (5x_n)}{n} \\ &= \frac{(x_1 + x_2 + x_3 + \dots + x_n) \times 5}{n} \quad (\text{using the distributive property}) \\ &= \frac{(x_1 + x_2 + x_3 + \dots + x_n)}{n} \times 5. \\ &= 5a. \end{aligned}$$

That is, the new average is 5 times more than the previous average.

Tinkering with Median

We know that the median is the middle value in the sorted data — there are an equal number of values less than it and greater than it.

- ? Will including a new value to the data increase or decrease the median?
Let us consider the following data. The median of this data is 8.

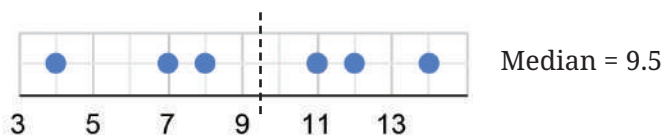
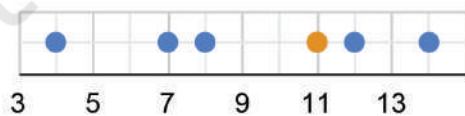
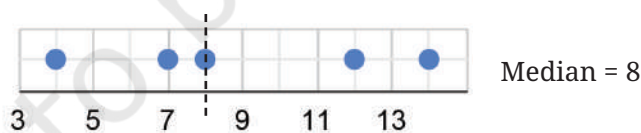

Suppose we include a value 11. The new value included is greater than the (earlier) median—the median can no longer be 8 as there are more values greater than it. Therefore, the median will also increase. The median, now, will be the average of the two middle values 8 and 11, which is 9.5.

We can similarly argue that when a value less than the median is included, the median will decrease.

Finding the Unknown

- ? Coach Balwan noted down the weights of the *kushti* players (wrestlers) and the mean as shown. But one value that was written down got smudged. Can you find out the missing value?

$$\text{Average weight of the players} = \frac{\text{Sum of weight of all players}}{\text{Number of players}}$$

Let the unknown weight be w kg.

$$= \frac{42 + 40 + 39 + 33 + 48 + 38 + 42 + 35 + 32 + w}{10} = 39.2.$$

Simplifying this we get,

$$349 + w = 392,$$

$$w = 392 - 349 = 43.$$

The missing value is 43 kg.

- ? Venkayya keeps track of the coconut harvest in his farm. He calculates the average harvest per tree as 25.6. His son verifies the counts and finds that one tree's harvest count is incorrectly noted as 3 more than the actual number. Can you find the correct average if the number of trees is 15?

$$\text{The average harvest per tree} = \frac{\text{Total number of coconuts harvested}}{\text{Number of trees}}$$

The data of harvest per tree is not given.

- ? Can we still find out the number of coconuts harvested?

Let the initial number of coconuts harvested be z . Based on what is given,

$$25.6 = \frac{z}{15},$$

Simplifying,

$$z = 25.6 \times 15 = 384.$$

The initial count of coconuts harvested is 384.

We know that one tree's count is 3 more than the actual. Therefore, the actual total harvest count is $384 - 3 = 381$.

The correct average harvest is $\frac{381}{15} = 25.4$.

42
40
39
33
48
38
42
35
32



Mean and Median with Frequencies

- ? What is the average family size of students in your class? How would you find this out?

We can collect the data of how many family members each student has, add them up, and divide it by the number of students. The family size data of students in a class is shown in the table here.

Number	Frequency
3	3
4	11
5	9
6	7
7	3
8	1
9	1
10	1

- ? What is the average family size of this class?

Some of you may have thought, “Easy! It will be $\frac{3+4+5+6+7+8+9+10}{8} = \frac{52}{8} = 6.5$.”

Remember that finding the average involves adding all the values in the data. The number 3 occurs three times, the number 4 occurs eleven times, and so on. Do these reflect in your calculation?

We know that the average = $\frac{\text{Sum of all the values in the data}}{\text{Number of value in the data}}$.

Accounting for the frequencies of each value, the average will be

$$= \frac{(3 \times 3) + (4 \times 11) + (5 \times 9) + (6 \times 7) + (7 \times 3) + (8 \times 1) + (9 \times 1) + (10 \times 1)}{3 + 11 + 9 + 7 + 3 + 1 + 1 + 1}$$

$$= \frac{9 + 44 + 45 + 42 + 21 + 8 + 9 + 10}{36}$$

$$= \frac{188}{36} = 5.22.$$

The average family size of this class is 5.22.

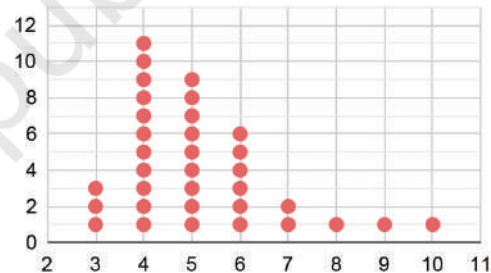

- ? What is the median family size of this class?

We know that there are 36 values in the data. The median would be the average of the 18th and 19th value in the sequence when the data is ordered.

- ? Do we need to write all the 36 numbers in order? Is there a quicker way to find out?

We can make use of the table where the frequencies are listed. We successively add the frequencies starting from the smallest value until we reach 18 and 19.

Number	3	4	5	6	7	8	9	10
Frequency	3	11	9	7	3	1	1	1

Adding the frequencies of 3 and 4, we get $3 + 11 = 14$. This means the value in the 14th position when the data is sorted is 4. Adding the frequencies of 3, 4, and 5, we get $3 + 11 + 9 = 23$. This means the value in the 23rd position when the data is sorted is 5. We can see that all the values from positions 15 to 23 are 5. Therefore, the median of this data is 5.

Spreadsheets

Sudhakar has collected the mid-term exam marks obtained by his Grade 8 students in the following table:

Name	Odia	Telugu	English	Maths	Social Science	Science
Ratna	25	39	29	36	34	37
Nagesh	41	43	48	39	40	39
Ashwin	29	31	33	34	30	28
Farooq	47	46	38	42	49	44
Mrinal	33	35	28	32	30	36
Gowri	27	29	34	31	32	30
Pankaj	16	19	22	17	18	20
Jaya	31	38	40	50	43	46
Ganesh	39	37	35	38	36	40
Shravan	12	17	21	20	14	18
Aishwarya	48	45	46	47	44	43
Hari	25	28	24	21	23	26
Trupti	29	36	30	33	27	33
Veeresh	23	25	28	31	19	22
Vidhya	34	36	37	40	32	34
Sanskriti	35	42	41	46	38	40
Shanker	42	45	39	36	31	39
Vyshnavi	37	32	29	33	31	35
Govind	15	18	12	20	20	18
Shiva	29	24	32	34	28	30
Tarun	41	44	39	43	37	42
Jyothi	29	30	33	28	34	29

Sudhakar has to calculate the total marks scored by each student. He is also interested in knowing the average marks scored in each subject. But there are so many numbers! He will have to spend too much time and effort to complete this task. Of course, he can use a calculator to speed up the task.

Is there any way to further quicken this process?

One way is to use a computer. Computers have different applications/tools that can be used to perform tasks. One such application is a spreadsheet—it is like a digital notebook with rows and columns of small boxes called **cells**. In each cell, we can type text or numbers. The picture below shows a snapshot of a spreadsheet where Sudhakar has entered the marks data of his class. Try to get access to a computer before proceeding.

	A	B	C	D	E	F	G	H
1	Name	Odia(R1)	Telugu(R2)	English(R3)	Maths	Social	Science	Total
2	Ratna	25	39	29	36	34	37	
3	Nagesh	41	43	48	39	40	39	
4	Ashwin	29	31	33	34	30	28	
5	Farooq	47	46	38	42	49	44	
6	Mrinal	33	35	28	32	30	36	
7	Gowri	27	29	34	31	32	30	
8	Pankaj	16	19	22	17	18	20	

Before learning how to calculate the average marks per subject and the total marks scored by each student, let us first understand the structure of spreadsheets and how to read them.

❓ Can you tell which cell has the marks obtained by Farooq in Mathematics?

Cells are named and referred to using the column headers labelled A, B, C, ..., and row headers labelled 1, 2, 3, ... Farooq's score in Mathematics is in cell E5.

❓ Can you tell what data is in column B7?

❓ In which subjects has Ashwin scored more than 30 marks?

How can we use spreadsheets to quickly calculate totals and averages? In addition to text and numbers, we can also enter formulae in a cell. We can write a formula that computes the sum or average of a row, or column of cells.

We can describe a row of cells by an expression of the form Start:End, indicating the first and last cell in the row. For instance, Nagesh's marks are described by the expression B3:G3, while Gowri's marks in Odia, Telugu and English are described by the expression B7:D7. We can use similar expressions to describe columns. For instance, D2:D6 describes the marks in English for the first five students.

We can then write a formula to compute the sum or the average of a row or column. For instance `=SUM(B3:G3)` calculates the total marks for Nagesh across all subjects, while `=AVERAGE(B7:D7)` calculates Gowri's average marks across Odia, Telugu and English.

H3 fx =SUM(B3:G3)

	A	B	C	D	E	F	G	H
1	Name	Odia(R1)	Telugu(R2)	English(R3)	Maths	Social	Science	Total
2	Ratna	25	39	29	36	34	37	250 x
3	Nagesh	41	43	48	39	40	39	=SUM(B3:G3)
4	Ashwin	29	31	33	34	30	28	
5	Farooq	47	46	38	42	49	44	
6	Mrinal	33	35	28	32	30	36	
7	Gowri	27	29	34	31	32	30	
8	Pankaj	16	19	22	17	18	20	

- ❓ What formula would you type to find out the class average marks in Science?
- ❓ Find out if the class average marks in Odia is greater than the class average marks in Telugu.
- ❓ Show the average marks in other subjects after the last row by typing the appropriate formulae.

Try these out on a computer. You can download the tabular data from this QR code.

- ❓ Get the total scores of each student by typing the appropriate formulae.



Note to the Teacher: You can use any spreadsheet software application such as Microsoft Excel, Google Sheets, LibreOffice Calc, etc. If there are not sufficient computers for each student, students can share a computer in groups. If that's not possible, the computer screen can be projected for the whole class if there is only one computer available.

❓ Figure it Out

1. Find the mean of the following data and share your observations:
 - (i) The first 50 natural numbers.
 - (ii) The first 50 odd numbers.
 - (iii) The first 50 multiples of 4.
2. The dot plot below shows a collection of data and its average; but one dot is missing. Mark the missing value so that the mean is 9 (as shown below).

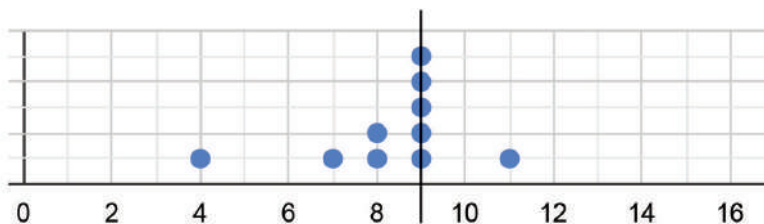

3. Sudhakar, the class teacher, asks Shreyas to measure the heights of all 24 students in his class and calculate the average height. Shreyas informs the teacher that the average height is 150.2 cm. Sudhakar discovers that the students were wearing uniform shoes when the measurements were taken and the shoes add 1 cm to the height.

(i) Should the teacher get all the heights measured again without the shoes to find the correct average height? Or is there a simpler way?

(ii) What is the correct average height of the class?

- (a) 174.2 cm (b) 126.2 cm (c) 150.2 cm
 (d) 149.2 cm (e) 151.2 cm (f) None of the above
 (g) Insufficient information

4. The three dot plots below show the lengths, in minutes, of songs of different albums. Which of these has a mean of 5.57 minutes? Explain how you arrived at the answer.

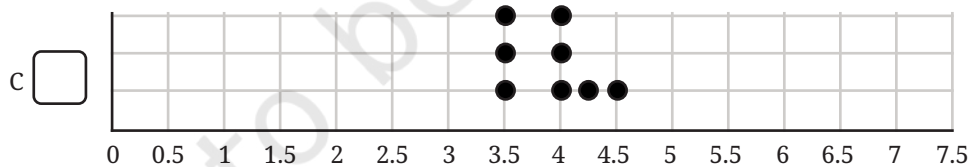
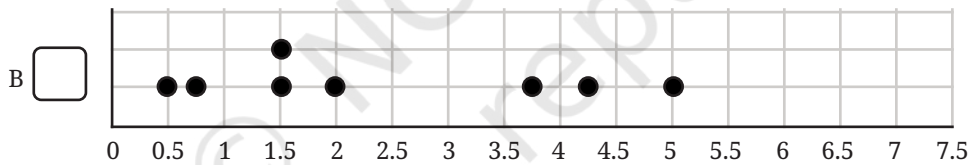
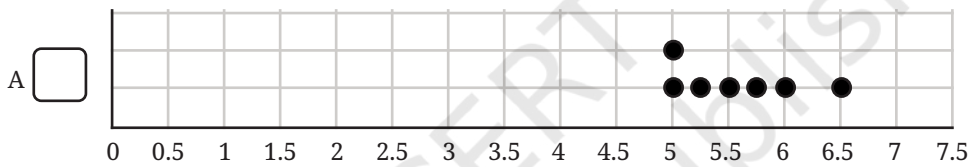

5. Find the median of 8, 10, 19, 23, 26, 34, 40, 41, 41, 48, 51, 55, 70, 84, 91, 92.



- (i) If we include one value to the data (in the given list) without affecting the median, what could that value be?
 (ii) If we include two values to the data without affecting the median what could the two values be?
 (iii) If we remove one value from the data without affecting the median what could the value be?

6. Examine the statements below and justify if the statement is always true, sometimes true, or never true.
 - (i) Removing a value less than the median will decrease the median.
 - (ii) Including a value less than the mean will decrease the mean.
 - (iii) Including any 4 values will not affect the median.
 - (iv) Including 4 values less than the median will increase the median.
7. The mean of the numbers 8, 13, 10, 4, 5, 20, y , 10 is 10.375. Find the value of y .
8. The mean of a set of data with 15 values is 134. Find the sum of the data.
9. Consider the data: 12, 47, 8, 73, 18, 35, 39, 8, 29, 25, p . Which of the following number(s) could be p if the median of this data is 29?

(i) 10	(ii) 25	(iii) 40	(iv) 100
(v) 29	(vi) 47	(vii) 30	
10. The number of times students rode their cycles in a week is shown in the dot plot below. Four students rode their cycles twice in that week.

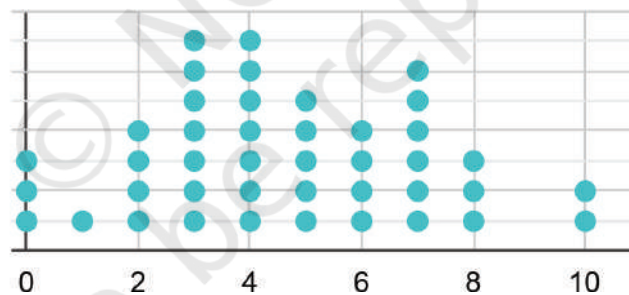

- (i) Find the average number of times students rode their cycles.
- (ii) Find the median number of times students rode their cycles.
- (iii) Which of the following statements are valid? Why?
 - (a) Everyone used their cycle at least once.
 - (b) Almost everyone used their cycle a few times.
 - (c) There are some students who cycled more than once on some days.
 - (d) Exactly 5 students have used their cycles more than once on some days.

- (e) The following week, if all of them cycled 1 more time than they did the previous week, what would be the average and median of the next week's data?

11. A dart-throwing competition was organised in a school. The number of throws participants took to hit the bull's eye (the centre circle) is given in the table below. Describe the data using its minimum, maximum, mean and median.

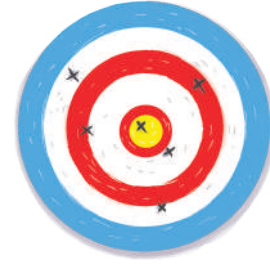

No. of trials	1	2	3	4	5	6	7	8	9	10
No. of students	1	0	0	1	4	9	12	15	10	10

5.2 Visualising and Interpreting Data

So far we have learnt how to read and make pictographs, bar graphs, clustered-bar graphs, and dot plots. We now examine some more ways of visualising data.

Line Graphs

Temperature

The following figure is a clustered-column graph that shows the monthly maximum temperature in Kerala and Punjab in 2023.

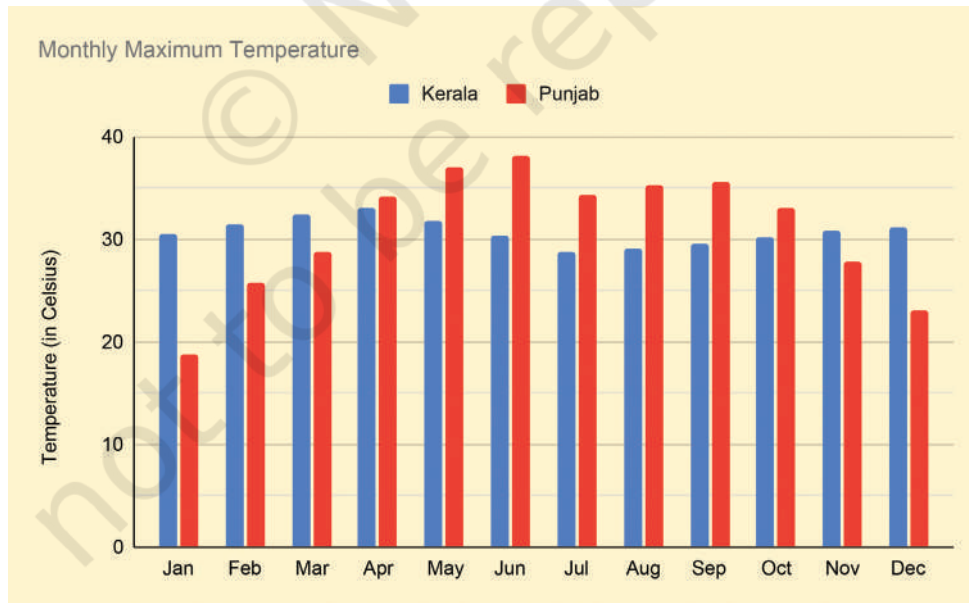

- ? Now, observe the following graph. Do both these graphs represent the same information?

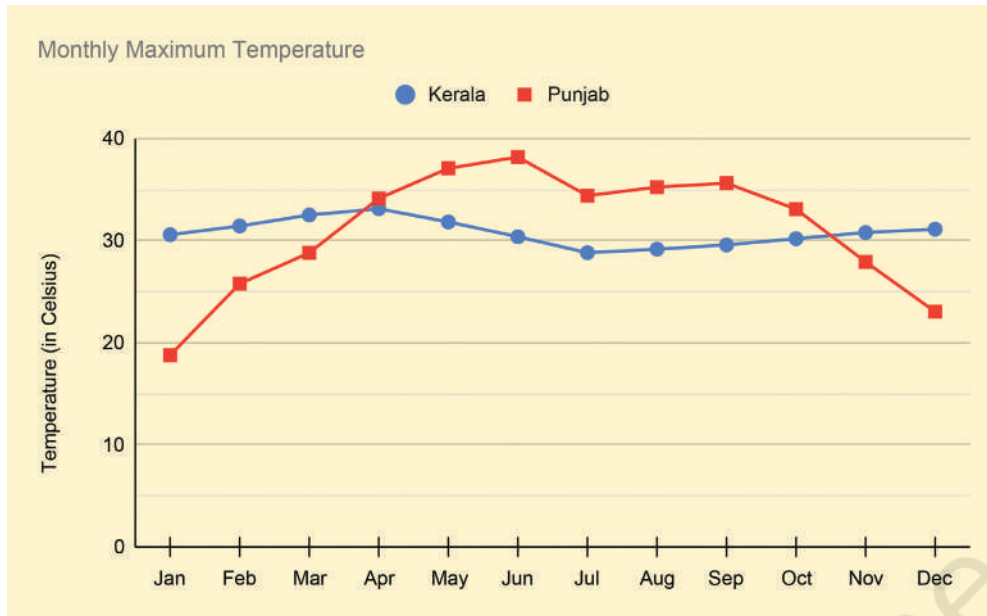

We call such a graph made up of lines a **line graph**. Line graphs are generally used to visualise data across time.

? How do we get the maximum temperature over a month in a state?

There could be a few weather stations across the state that regularly track the local temperature. We can get the monthly maximum temperature by looking at the maximum value among all the values recorded across the state.



When we try to understand how the data is collected or produced, we gain a clearer idea of its scope and can interpret it more meaningfully. It also helps us identify any limitations, such as bias or missing information, and decide how confidently we can draw conclusions from the data.

To identify and interpret the information presented, let us follow a two-step process.

Step 1: Identify what is given

? Notice how the graph is organised, what scale is used, and what patterns the data shows.

- The data for each month for a city is marked and connected by lines to show the change over time. Kerala's data is shown using blue circle marks connected by blue lines and Punjab's data is shown in red.

The different shape markers help in easily distinguishing if the graph is printed in greyscale/black-and-white, or for people who find it difficult to distinguish colour.

- The horizontal line shows the months of the year. The vertical line shows the temperature in °C.

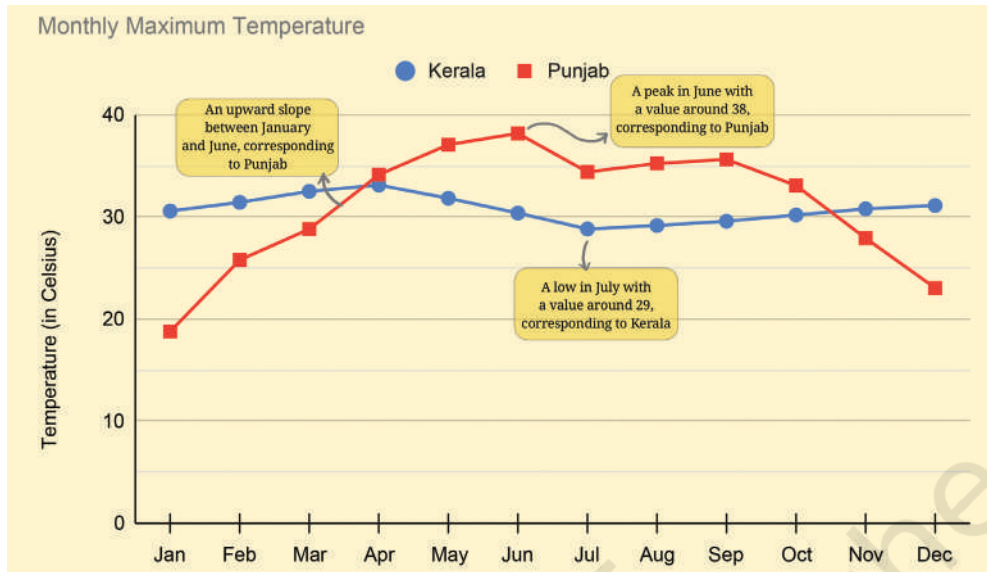

Step 2: Infer and interpret from what is given

? Analyse and interpret each of the observations you made. Share appropriate summary/conclusion statements.

- In Punjab, the monthly maximum temperature increases from January to June, reaching a high of 38°C. Then, it reduces to just under 35°C in July, stays mostly flat till September, and then falls continuously till December, reaching about 23°C. January has the lowest among the monthly maximum temperature of about 19°C.
- Kerala's trend is different — it stays mostly flat throughout the year. The peak is around 33°C in April and the lowest point is around 29°C in July. Notice that the monthly maximum temperatures in Kerala are similar both in summer and winter!
- In short, the temperature in Punjab varies more, reaching colder and warmer temperatures than in Kerala.

This can trigger questions in different directions, some of which can be answered using data. Here are some directions to think about —

- Why are the trends so distinct in these two states? What factors determine a region's temperature?
- You might be curious to look at the trends of a few other states. Are there other types of trends that states exhibit?
- Which states show trends similar to Punjab's? Is there anything common between these states?

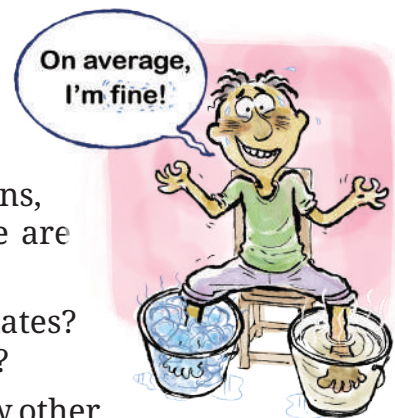

- What would a plot of the monthly minimum temperatures for these states look like?

? What thoughts or questions occur to you?



Space Jam: A Traffic Problem in the Future?

Take a look at the line graph below showing the annual number of objects launched into space.

Annual number of objects launched into space

Including satellites, probes, landers, crewed spacecrafts, and space station flight elements launched into Earth orbit or beyond.

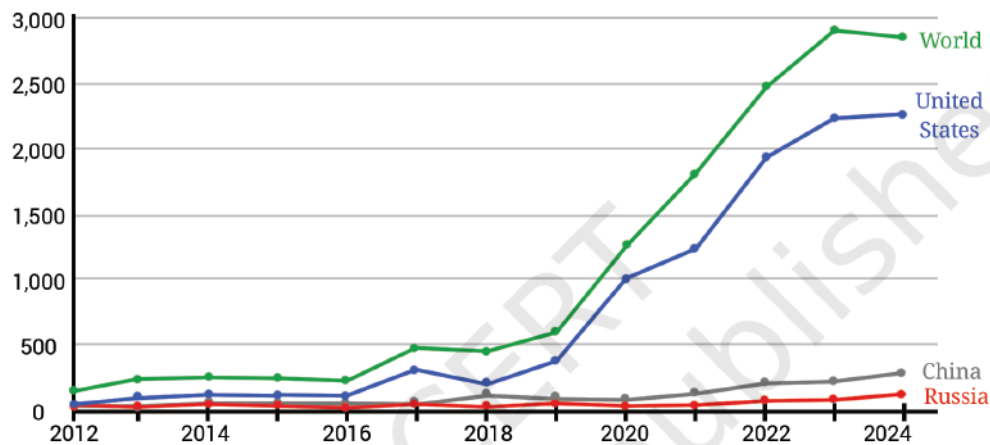

Source: United Nations Office for Outer Space Affairs (2025)

? What could be the possible method used to derive this data? Discuss.



Step 1: Identify what is given

? Notice how the graph is organised, what scale is used, and what patterns the data shows.

Step 2: Infer from and interpret what is given

? Analyse and interpret each of the observations you made. Once all interpretations are made, summarising/concluding statements can be made.

- In 2024, the worldwide count is around 2800, whereas in 2023, it was around 2900. We can say that 2023 saw the highest number of objects launched into space worldwide (assuming the trend before 2012 was decreasing).
- The counts of the three countries don't add up to the worldwide count. Therefore, we can infer that the counts of other countries are not shown in this visualisation.

- For the USA, the increase from 2022 to 2023 is more than from 2023 to 2024. We can say this by looking at how steep the line segments are — the steeper the line is, the greater the increase.

❓ Which of the following statements are valid inferences?

- From 2012 till 2024, the worldwide count of space object launches increased every year.
- USA is a major contributor in the years 2022–24, launching about $\frac{3}{4}$ th of the worldwide count.
- Nepal did not launch any object in the period 2012–24.
- The combined count of object launches by China and Russia in 2024 is about 400.

❓ Identify two consecutive years where the worldwide count increased by 2 times or more.

Imagine the same data being shown as a clustered column graph. There would be 13 clusters — one for each year — and within each cluster, 4 columns, making a total of 52 bars! Such a graph would look crowded and difficult to read, making it hard to interpret the trends clearly.

A line graph, on the other hand, is better suited for illustrating changes over time. By connecting data points with line segments, it provides a clear visual representation of trends and variations, allowing the reader to easily track how a parameter evolves across different years.

Catch the (Pattern in) Rain

The following graphs show monthly average rainfall data of a few cities.

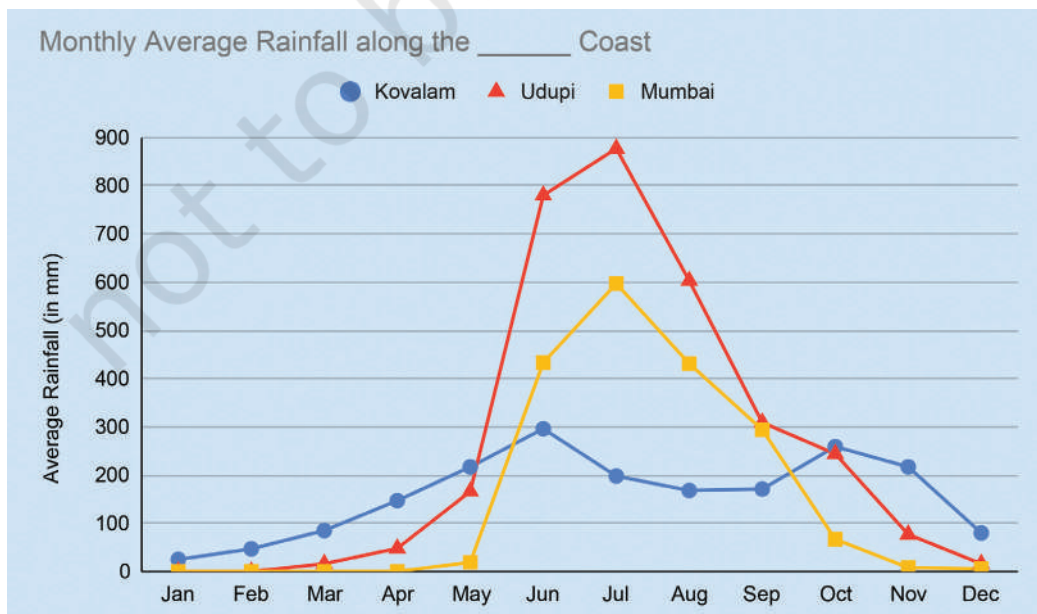

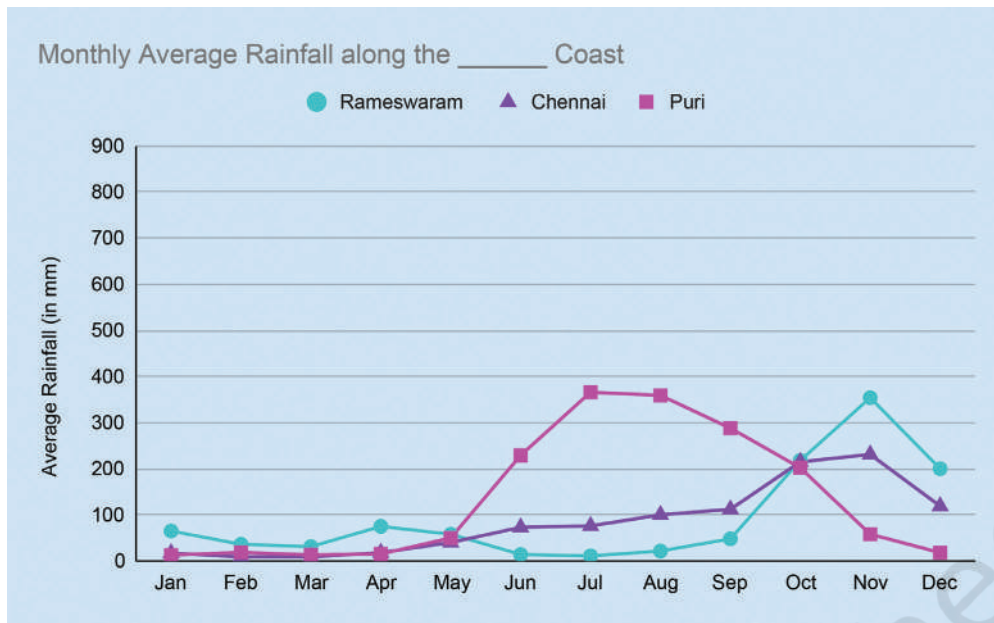

Source: weather-and-climate.com

- ? What could be the possible method to compile this data?

This data shows the monthly average rainfall in 6 cities. This means rainfall data is collected over a few years in every city. The total rainfall in a month, say June, across years is averaged to get the monthly average rainfall in June in a city.

- ? Mark these cities on a map of India. What is common to how they are grouped in the graphs? Share your observations and inferences about the graphs.



Kovalam, Udipi, and Mumbai are along the west coast. Rameswaram, Chennai, and Puri are along the east coast. It appears that regions along the west coast receive more rain.

- ? Identify the peak months and low months of rainfall for each city.

Udipi, Mumbai, and Kovalam have peak rainfall during June – August. Rameswaram gets most of its rain during October – December. Chennai starts getting rain from June onwards, which peaks in November, and continues till December. Puri, although on the east coast, gets its peak rainfall during July – September. January – March are dry months, with low rainfall, for all the cities. Rameswaram receives very little rain from January – September.

- ? Read about the south-west monsoon and north-east monsoon and which regions come under the influence of these and when.

? Figure it Out

- The average number of customers visiting a shop and the average number of customers actually purchasing items over different days of the week is shown in the table below. Visualise this data on a line graph.

	Mon	Tue	Wed	Thu	Fri	Sat	Sun
Visiting	16	19	10	14	20	22	35
Purchasing	10	8	7	11	12	16	26

- The average number of days of rainfall in each month for a few cities is shown in the table below:

	Jan	Feb	Mar	Apr	May	Jun	Jul	Aug	Sep	Oct	Nov	Dec
Mangaluru	0.1	0	0.1	1.8	6.2	24.1	27.7	24.5	14	8.8	3.9	0.9
New Delhi												
Port Blair	2.4	1.3	0.9	3.3	15.5	18.7	17.3	18.8	16.8	14.1	11.3	5.4
Rameswaram	2.6	1.3	1.9	3.4	2.5	0.4	1	1	1.9	8.1	10.4	7.8

- What could be the possible method to compile this data?
- Mark the data for Mangaluru, Port Blair, and Rameswaram in the line graph shown below. You can round off the values to the nearest integer.

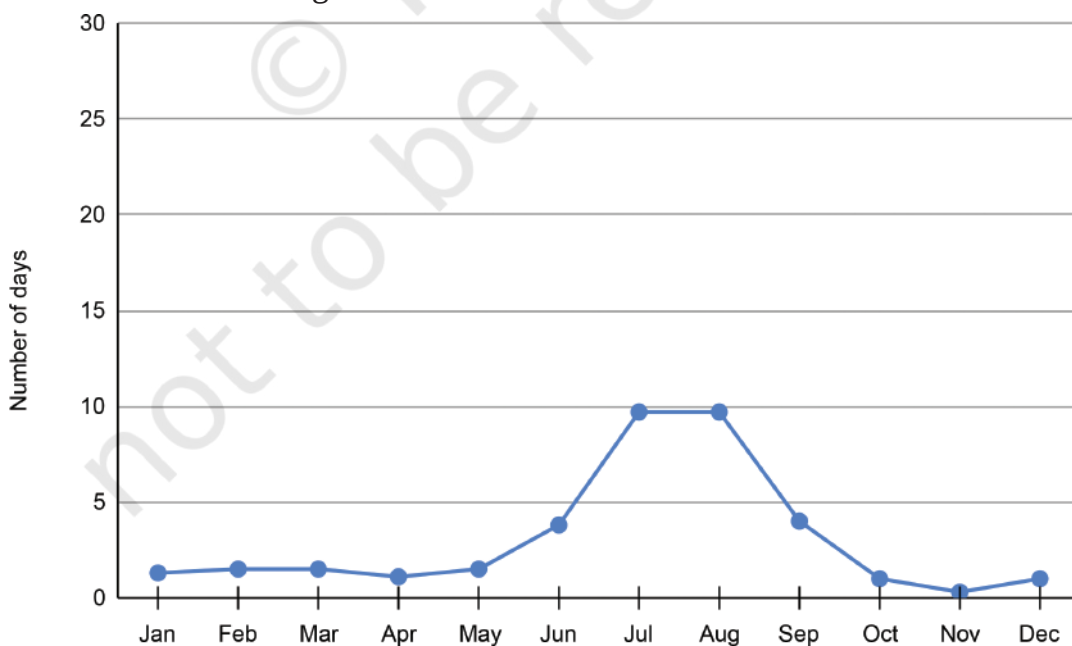

Source: weather-and-climate.com

- (iii) Based on the line for New Delhi in the graph fill the data in the table.
 - (iv) Which city among these receives the most number of days of rainfall per year? Which city gets the least number of days of rainfall per year?
 - (v) Looking at the table, when is the rainy season in New Delhi and Rameswaram?
2. The following line graph shows the number of births in every month in India over a time period:

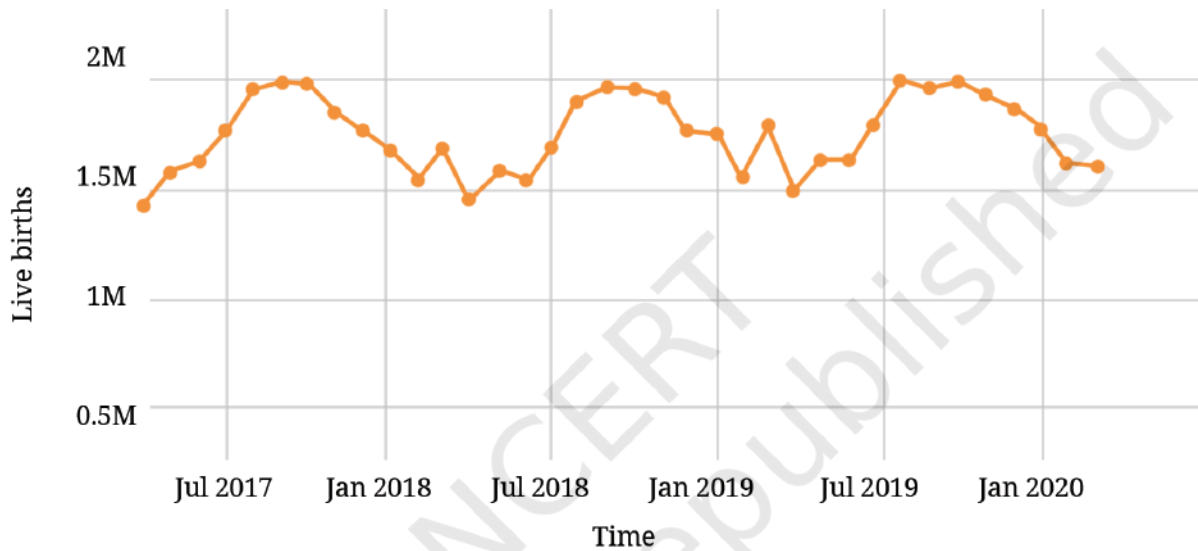

Source: Nambiar et al (Forthcoming) – “Seasonal variations in births in India”

- (i) What are your observations?
- (ii) What was the approximate number of births in July 2017?
- (iii) What time period does the graph capture?
- (iv) Compare the number of births in the month of January in the years 2018, 2019, and 2020.
- (v) Estimate the number of births in the year 2019.

Infographics

In Grade 6, we saw an example of how infographics can be used to communicate information and insights more clearly and quickly in a visually appealing way. Take a look at the following infographic. Are you able to understand the information presented here?

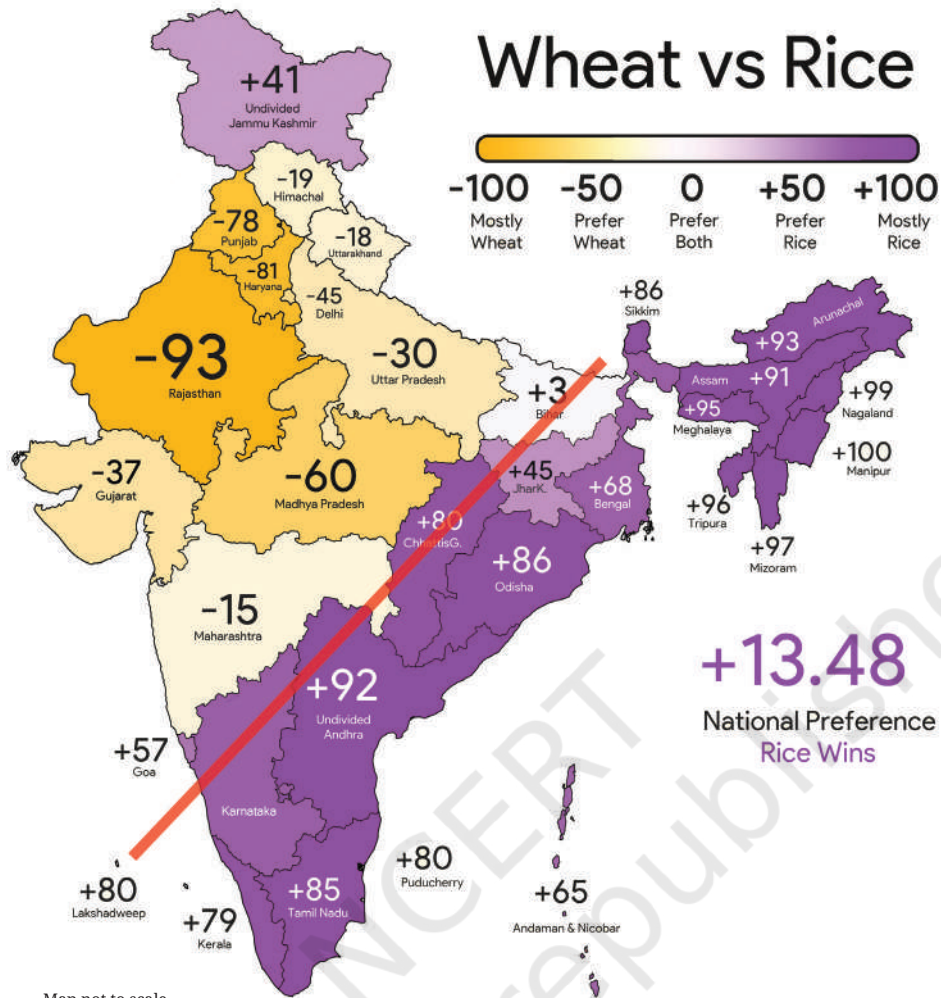

This infographic compares the preference between rice and wheat in different states. The colour scale at the top right indicates how to interpret the different shades in terms of preferences.

The difference between the per capita consumption of rice and wheat is mapped to values between -100 and $+100$. A value of $+100$ doesn't mean that the state doesn't consume wheat at all. It means that this state prefers mostly rice and the difference between per capita rice and wheat consumption is the highest. Isn't it interesting how there is a clear geographical split in preferences of rice vs. wheat shown by the red line?

? Share your observations. Based on this infographic, answer the following:

- (i) The value of Karnataka is hidden. Can you guess what it could be?
- (ii) Which are the top 5 states where rice is the most popular?
- (iii) Which are the top 5 states where wheat is the most popular?
- (iv) List a few states where the preference between rice and wheat is more or less balanced.

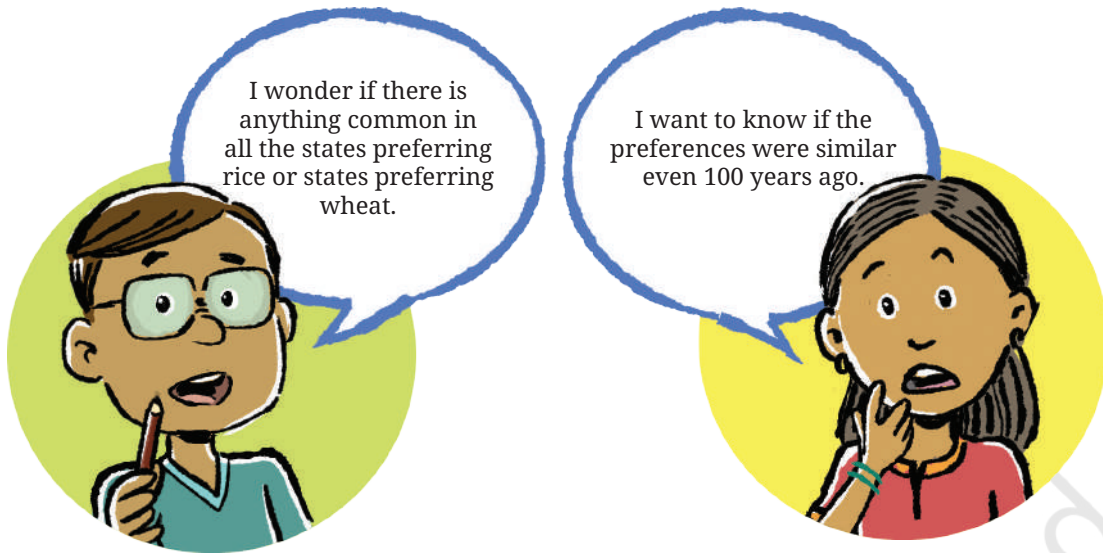

What can a Strip Say?

Manoj has an interesting hobby. He makes note of what he does throughout the day. He records his activities by colouring a strip of paper with 48 boxes, marking time in 30 minute intervals from midnight to midnight.

He has recorded five types of activities for three different days of the week on three coloured strips, shown to the right.

- (i) Sleeping
- (ii) Eating
- (iii) Meeting friends, hobbies, media, time with family
- (iv) Attending classes, studying and homework
- (v) Showering and getting dressed, yoga or exercise
- (vi) Travelling

? Look at the three coloured strips carefully.

- (i) What activity does each colour stand for?
- (ii) The three strips correspond to the days Friday – Sunday in some order. Which day do you think each strip represents?
- (iii) On one of these days, he went out with friends to watch a long movie. When do you think this happened?
- (iv) At what time does his school break for lunch?
- (v) What more can the strips tell us?

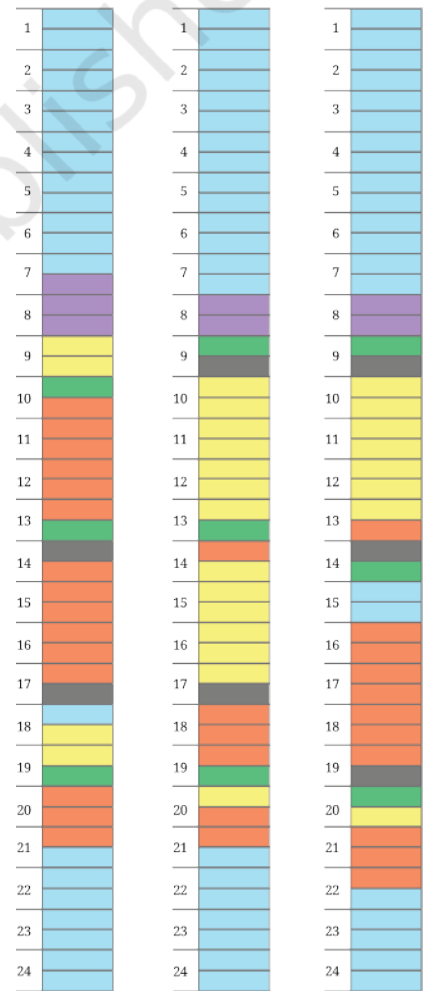

- ❓ What would your strip for a weekday look like? How similar or different is it to Manoj's?
- ❓ What would a strip of your typical day during your vacation look like? How similar/different would it look?
- ❓ What would a strip for any of the adults in your family look like? Make a strip of a day for any adult at home. Compare your strip with theirs. What do you find interesting?

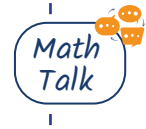

Data Story: Sleepy-Deepy

Do you remember the sleep time pie chart from the Proportionality chapter?

Isn't it amusing that there are animals that sleep as little as 2 hours per day and animals that sleep as much as 20 hours per day? How about insects—have you seen any insect sleep/rest? Humans typically sleep for about 7–9 hours a day. The sleep duration can vary greatly among people. The amount of sleep people need depends on age, living conditions, lifestyle (food they consume, the activities they engage in, etc.) among other factors. You may have observed that babies sleep longer than adults.

The line graphs below show typical sleep durations of Indians across ages 6 to 75. The second picture is a zoomed-in version of the first picture.

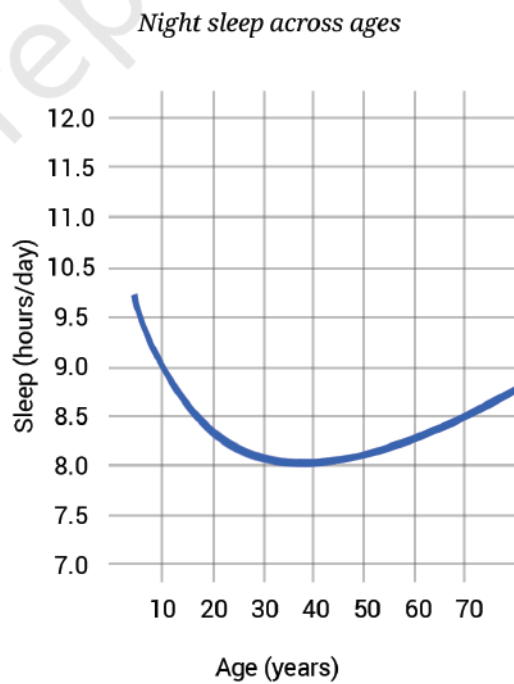
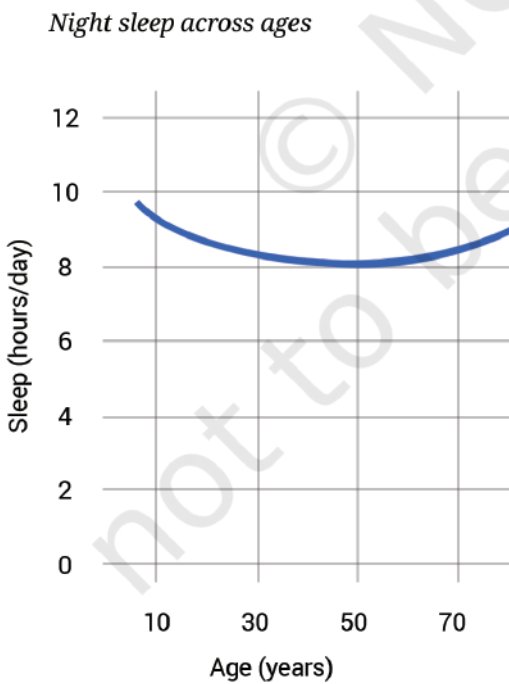

Source: National Time Use Survey 2024

- ? Share your observations on this graph. What do you find interesting?

Unlike the earlier graphs that were made up of a few connected line segments, this line graph looks like a smooth curve because it contains 80 data points that are placed very close to each other. Representing the same data using a column graph would require 70 columns, making the graph look cluttered and heavy. A line graph is a better choice here. It is light and captures the pattern well.

From the graph we can see that the average sleep time for 6-year olds is about 9.5 hours per day. The daily sleep time decreases as we grow through teenage years and step into adulthood, touching about 8 hours a day between ages 30 and 50. After 50, the daily sleep time increases, reaching about 8.5 hours.

You might wonder — why do newborns and infants sleep for so long? Do people in different countries sleep differently? Do animals also exhibit such patterns in sleep durations across age?

? **Figure it Out**

1. Mean Grids:

- (i) Fill the grid with 9 distinct numbers such that the average along each row, column, and diagonal is 10.
- (ii) Can we fill the grid by changing a few numbers and still get 10 as the average in all directions?

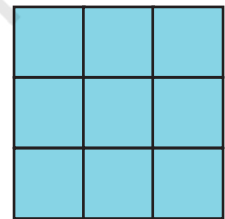

2. Give two examples of data that satisfy each of the following conditions:
 - (i) 3 numbers whose mean is 8.
 - (ii) 4 numbers whose median is 15.5.
 - (iii) 5 numbers whose mean is 13.6.
 - (iv) 6 numbers whose mean = median.
 - (v) 6 numbers whose mean > median.
3. Fill in the blanks such that the median of the collection is 13: 5, 21, 14, ____, ____, _____. How many possibilities exist if only counting numbers are allowed?
4. Fill in the blanks such that the mean of the collection is 6.5: 3, 11, ____, ____, 15, 6. How many possibilities exist if only counting numbers are allowed?
5. Check whether each of the statements below is true. Justify your reasoning. Use algebra, if necessary, to justify.
 - (i) The average of two even numbers is even.
 - (ii) The average of any two multiples of 5 will be a multiple of 5.
 - (iii) The average of any 5 multiples of 5 will also be a multiple of 5.

6. There were 2 new admissions to Sudhakar's class just a couple of days after the class average height was found to be 150.2 cm.
- Which of the following statements are correct? Why?
 - The average height of the class will increase as there are 2 new values.
 - The average height of the class will remain the same.
 - The heights of the new students have to be measured to find out the new average height.
 - The heights of everyone in the class has to be measured again to calculate the new average height.
 - The heights of the two new joinees are 149 cm and 152 cm. Which of the following statements about the class' average height are correct? Why?
 - The average will remain the same.
 - The average will increase.
 - The average will decrease.
 - The information is not sufficient to make a claim about the average.
 - Which of the following statements about the new class average height are correct? Why?
 - The median will remain the same.
 - The median will increase.
 - The median will decrease.
 - The information is not sufficient to make a claim about median.

7. Is 17 the average of the data shown in the dot plot below? Share the method you used to answer this question.

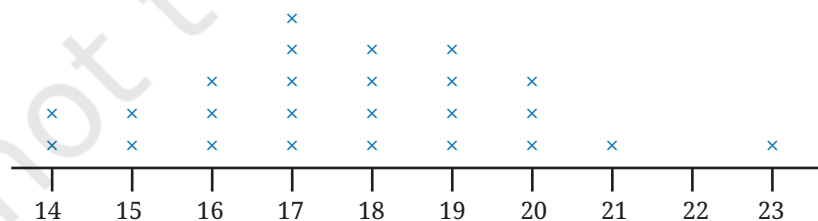

8. The weights of people in a group were measured every month. The average weight for the previous month was 65.3 kg and the median weight was 67 kg. The data for this month showed that



one person has lost 2 kg and two have gained 1 kg. What can we say about the change in mean weight and median weight this month?

9. The following table shows the retail price (in ₹) of iodised salt in the month of January in a few states over 10 years. For your calculations and plotting you may round off values to the nearest counting number.

	Andaman and Nicobar Islands	Assam	Gujarat	Mizoram	Uttar Pradesh	West Bengal
2016	16	6	16.5	20	16.15	9.47
2017	12	12	14.75	20	16.97	11.65
2018	12	12	14.75	22	16.18	11.63
2019	12	12	14.75	22	18.24	11.43
2020	13.88	12	13	20	18.96	11.11
2021	18.22	15	14.45	22	20.63	12.79
2022	18.73	14	14.28	25	21.3	16.14
2023	20.63	12.02	14.54	27.65	25.39	18.43
2024	19.73	13.72	14.8	29.03	26.9	21.66
2025	20.99	12.35	19.2	29.8	24.81	23.99

- (i) Choose data from any 3 states you find interesting and present it through a line graph using an appropriate scale.
- (ii) What do you find interesting in this data? Share your observations.
- (iii) Compare the price variation in Gujarat and Uttar Pradesh.
- (iv) In which state has the price increased the most from 2016 to 2025?
- (v) What are you curious to explore further?

10. Referring to the graph below, which of the following statements are valid? Why?

Primary source of energy for household lighting over time

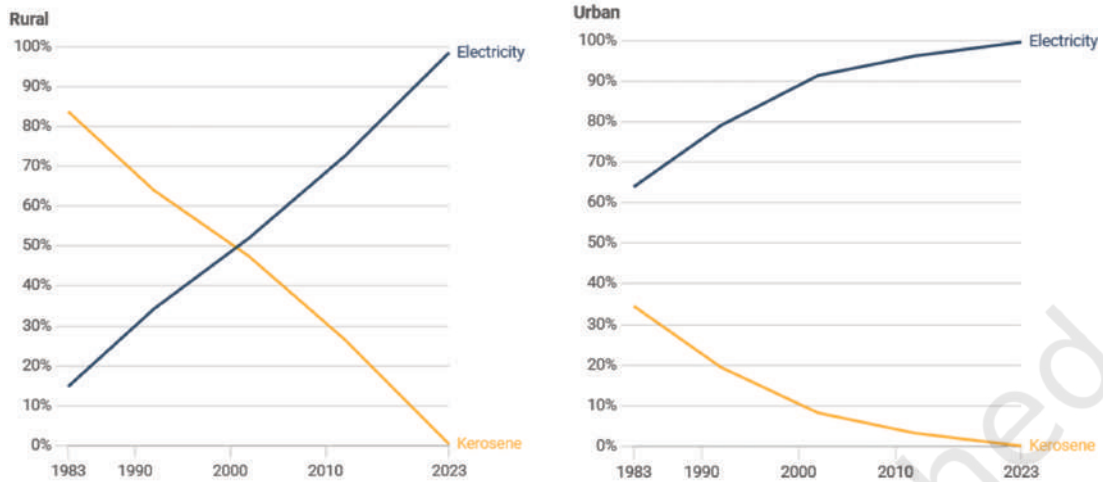

Numbers represent share of households by primary source of energy used for lighting
 Source: Household Consumer Expenditure Survey (HCES), various years, by National Sample Survey Office (NSSO)

Data For India

- (i) In 1983, the majority in rural areas used kerosene as a primary lighting source while the majority in urban areas used electricity.
- (ii) The use of kerosene as a primary lighting source has decreased over time in both rural and urban areas.
- (iii) In the year 2000, 10% of the urban households used electricity as a primary lighting source.
- (iv) In 2023, there were no power cuts.

11. Answer the following questions based on the line graph.

- (i) How long do children aged 10 in urban areas spend each day on hobbies and games?
 - (ii) At what age is the average time spent daily on hobbies and games by rural kids 1.5 hours?
- (a) 8 years
 - (b) 10 years
 - (c) 12 years
 - (d) 14 years
 - (e) 18 years

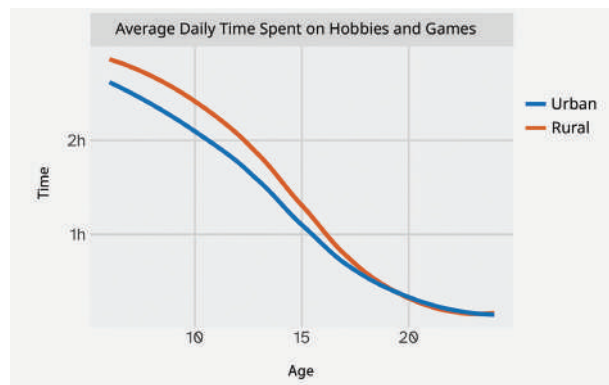

- (iii) Are the following statements correct?
- The average time spent daily on hobbies and games by kids aged 15 is twice that of kids aged 10.
 - All rural kids aged 15 spend at least 1 hour on hobbies and games everyday.



12. Individual project: Make your own activity strip for different days of the week.
- Do you eat and sleep at regular times every day? Typically how long do you spend outdoors?
 - Calculate the average time spent per activity. Represent this average day using a strip.
 - Similarly, track the activities of any adult at home. Compare your data with theirs.



13. Small group project: Make a group of 3–4 members. Do at least one of the following:
- Track daily sleep time of all your family members for a week. Daily sleep time includes night sleep, naps, and any sleep during the day.
 - Represent this on strips.
 - Put together the data of all your group members. Calculate the average and median sleep time of children, adults, elderly.
 - Share your findings and observations.
 - When do schools start and end? On a weekday, Manoj's school starts at 9:30 am and ends at 4:30 pm, i.e., 7 hours which include class time and breaks. Collect information on the daily timings of different schools for Grade 8, including class time and break time (the schools can be anywhere in the country. You can ask your neighbours, relatives, parents and friends to find out). Analyse and present the data collected.
14. The following graphs show the sunrise and sunset times across the year at 4 locations in India. Observe how the graphs are organised. Are you able to identify which lines indicate the sunrise and which indicate the sunset?

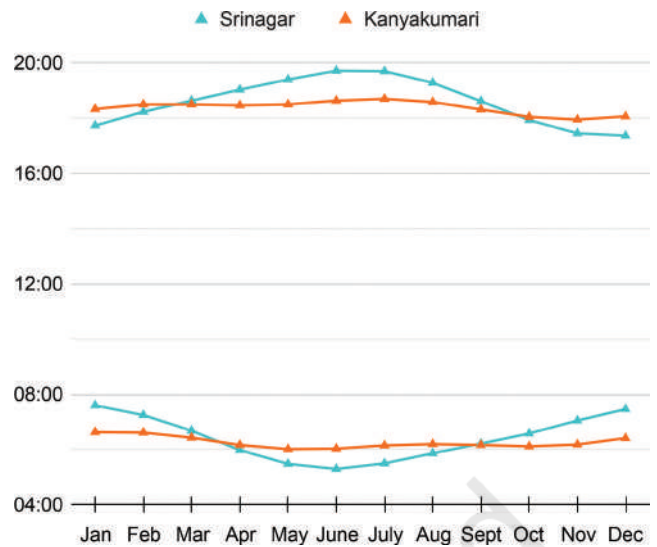
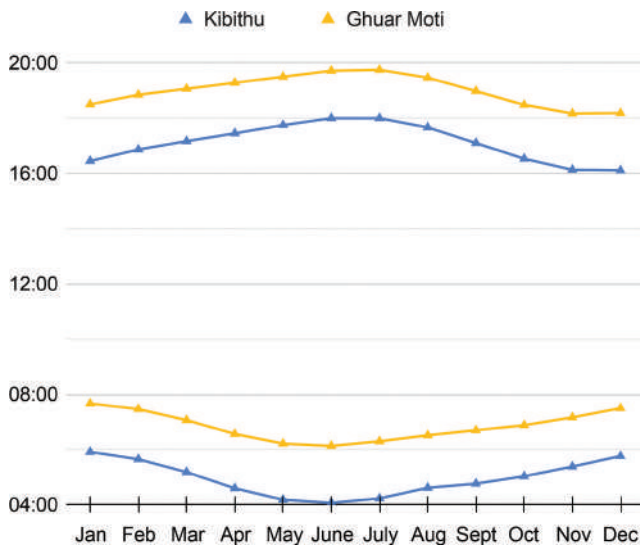

Answer the following questions based on the graphs:

- (i) At which place does the sun rise the earliest in January? What is the approximate day length at this place in January?
- (ii) Which place has the longest day length over the year?
- (iii) Share your observations — what do you find interesting? What are you curious to find out?

15. We all know the typical sunrise and sunset timings. Do you know when the moon rises and sets? Does it follow a regular pattern like the sun? Let's find out. The following graph shows the moonrise and moonset time over a month:



- (i) Find out on what dates *amavasya* (new moon) and *purnima* (full moon) were in this month.
- (ii) What do you notice? What do you wonder?

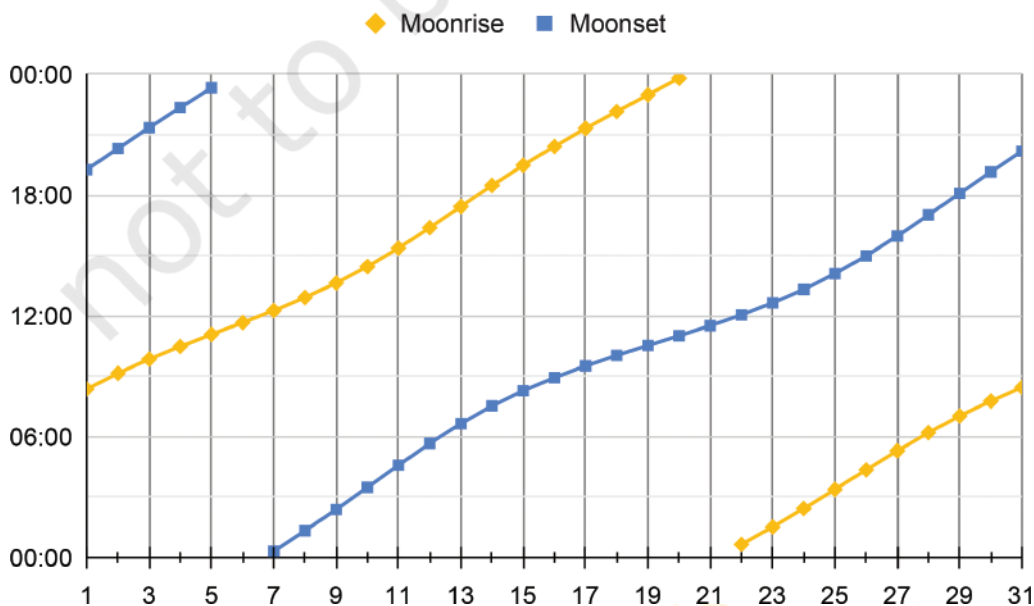

SUMMARY

- Last year we looked at mean as a fair-share. Here, we learnt how the sum of the distances of the values to its left and right are the same.
- We saw that when values greater than the mean are inserted, the mean increases. When values less than the mean are inserted, the mean decreases. Similar phenomena can be observed with the median.
- Line graphs can be used to visualise change over time.
- We saw that examining data can lead to new questions and directions to probe further.

© NCERT
not to be republished



IT'S PUZZLE TIME!

Game of Hex

Hex is a two-player strategy game played on a rhombus-shaped board made of hexagonal cells, usually of size 11×11 . Each player is assigned a colour and two opposite sides of the board. Players take turns placing a piece of their colour on any empty cell. Once placed, pieces can not be moved or removed. The objective is to create an unbroken chain of one's own pieces connecting the two assigned sides. The first player to complete such a connection wins the game. The pictures below show two possible gameplays where blue wins in the first and red wins in the second board.

Here is an empty board. You can use pencils to play each round and erase the marks to play a fresh round.

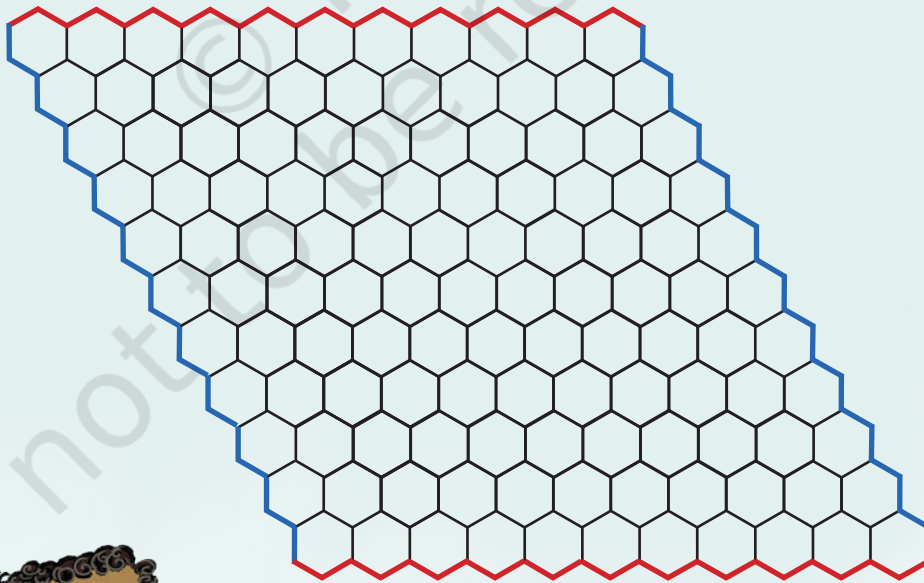
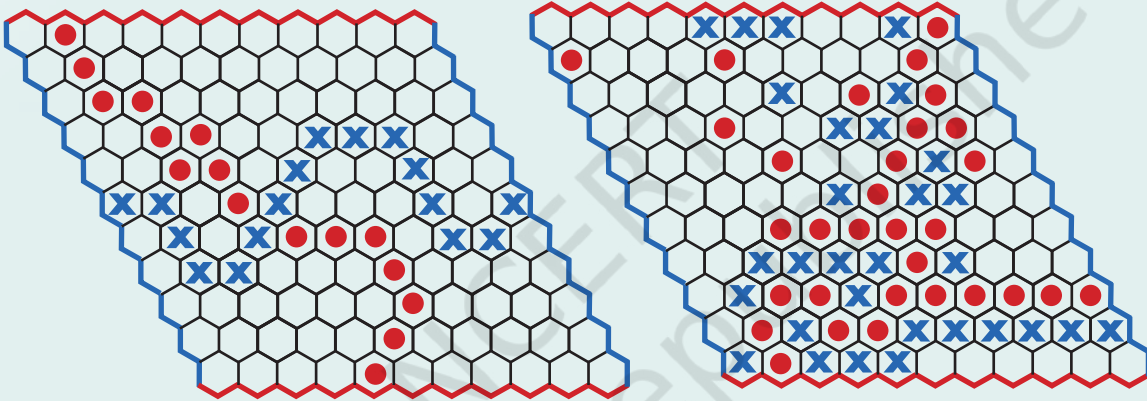

6

ALGEBRA PLAY



6.1 Algebra Play

Over the last two years, we have used algebra to model different situations. We have learned how to solve algebraic equations and find the values of unknown letter-numbers. Let's now have some fun with algebra. We shall investigate tricks and puzzles, and explain why they work using algebra. We will also see how to invent new tricks and puzzles to entertain others.

6.2 Thinking about 'Think of a Number' Tricks

In Grade 7, we learned about 'Think of a Number' tricks, like this one.

1. Think of a number.
2. Double it.
3. Add four.
4. Divide by two.
5. Subtract the original number you thought of.

? I predict you get 2. Am I right? Try it out with different starting numbers. Do you always end up with the same value, 2? Why?

We saw that we can understand such tricks through algebra.

1. Think of a number: x
2. Double it: $2x$
3. Add four: $2x + 4$
4. Divide by 2: $x + 2$
5. Subtract the original number you thought of: $x + 2 - x = 2$

Therefore, no matter what the starting number is, the end result will always be 2!

- ❓ How would you change this game to make the final answer 3? What about 5?
- ❓ Can you come up with more complicated steps that always lead to the same final value?

Let us now look at a different trick of this type.



- ❓ How did Shubham figure out the date chosen by Mukta?
 - Let the month be M and the day be D .
 - Multiply M by 5: $5M$

- Add 6: $5M + 6$
- Multiply by 4: $20M + 24$
- Add 9: $20M + 33$
- Multiply by 5: $100M + 165$
- Add the day: $100M + 165 + D$

Mukta's answer was 291.

- $291 = 100M + 165 + D$
- $291 - 165 = 100M + D$
- $126 = 100M + D$

Since D is a day within a month, it is at most 31 and requires only 2 digits. So the last 2 digits are D and what comes before that is M . In this case, M is 1 and D is 26, i.e., the 26th of January.

? Mukta thinks of another date, follows the same steps, and reports her answer as 1390. What date did Mukta start with this time?

- Subtracting 165 from 1390, we get 1225.
- This means that the date she thought of was 25th December.

? Find the dates if the final answers are the following:

- 1269
- 394
- 296

You can try this trick with your friends. Ask them to choose the starting date as their birthday.

? Can you change the steps in this trick and still find the original date? Instead of subtracting 165 from the final answer, you might have to subtract some other number.



? Try to devise your own 'Think of a Number' trick.



6.3 Number Pyramids

In a number pyramid, each number is the sum of the two numbers directly below it (see the figure).

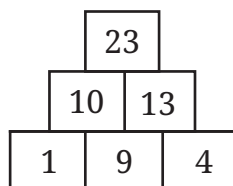

? Use the same rule to fill these pyramids:

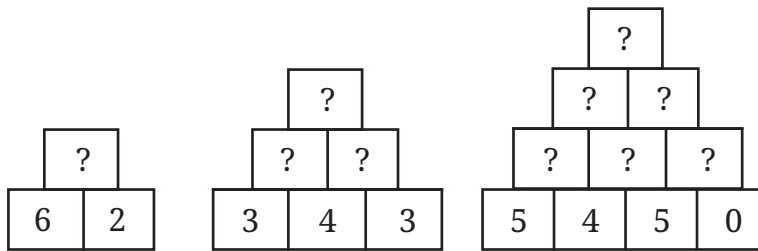

? How do we fill this pyramid?

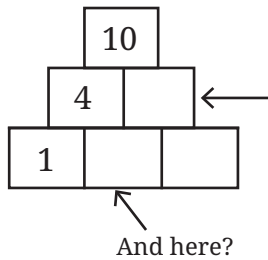
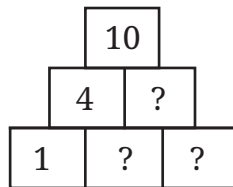

What will go here?

And here?

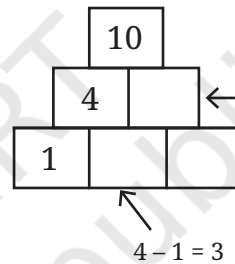

$$10 - 4 = 6$$

$$4 - 1 = 3$$

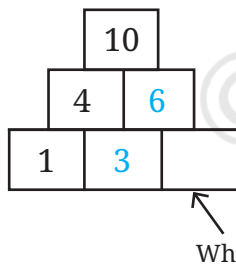

What will go here?

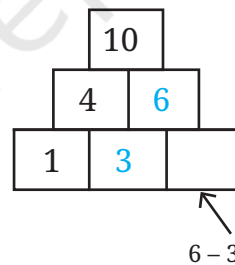

$$6 - 3 = 3$$

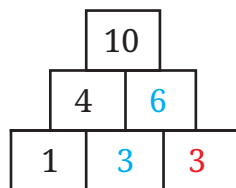

? What about filling in the numbers in this pyramid? Where do we start?

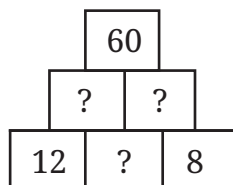

Let us fill the empty boxes with letter-numbers.

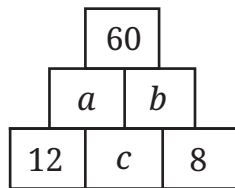

From the rules for filling up pyramids, we get the following equations.

- $a + b = 60$
- $12 + c = a$
- $c + 8 = b$

From this, we see that,

- $(12 + c) + (c + 8) = a + b = 60$

Hence,

- $20 + 2c = 60$
- $2c = 60 - 20 = 40$
- $c = 20$.

Once we know c , we can find a and b , and complete the pyramid.

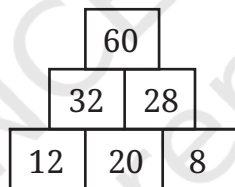

? Fill the following pyramids:

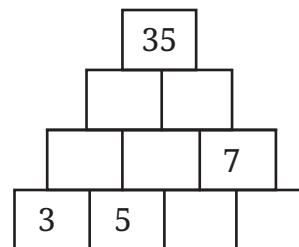
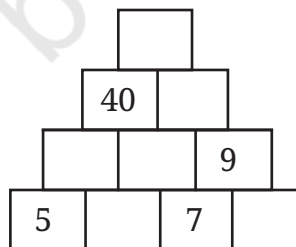
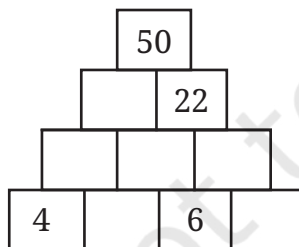

? What is the relationship between the numbers in the bottom row and the number at the top?

Let us start with the simplest pyramid.

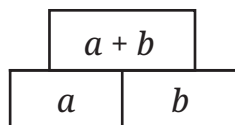

? What about a pyramid with three rows?

Using letter numbers for the bottom row, we can write an expression for the top row.

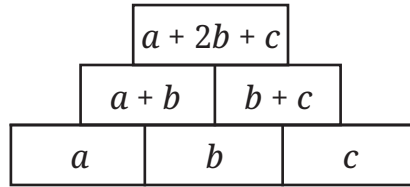

? **Figure it Out**

1. Without building the entire pyramid, find the number in the topmost row given the bottom row in each of these cases.

4	13	8
---	----	---

7	11	3
---	----	---

10	14	25
----	----	----

2. Write an expression for the topmost row of a pyramid with 4 rows in terms of the values in the bottom row.

3. Without building the entire pyramid, find the number in the topmost row given the bottom row in each of these cases.

8	19	21	13
---	----	----	----

7	18	19	6
---	----	----	---

9	7	5	11
---	---	---	----

Recall the Virahāñka-Fibonacci number sequence 1, 2, 3, 5, ... where each number is the sum of the two numbers before it.

4. If the first three Virahāñka-Fibonacci numbers are written in the bottom row of a number pyramid with three rows, fill in the rest of the pyramid. What numbers appear in the grid? What is the number at the top? Are they all Virahāñka-Fibonacci numbers?

5. What can you say about the numbers in the pyramid and the number at the top in the following cases?

(i) The first four Virahāñka-Fibonacci numbers are written in the bottom row of a four row pyramid.

(ii) The first 29 Virahāñka-Fibonacci numbers are written in the bottom row of a 29 row pyramid.

6. If the bottom row of an n row pyramid contains the first n Virahāñka-Fibonacci numbers, what can we say about the numbers in the pyramid? What can we say about the number at the top?

6.4 Fun with Grids

Calendar Magic

A page from a calendar is given below. Your friend picks a 2×2 grid from this calendar, adds the 4 numbers in this grid and tells you the sum.

AUGUST 2025						
SUN	MON	TUE	WED	THU	FRI	SAT
					1	2
3	4	5	6	7	8	9
10	11	12	13	14	15	16
17	18	19	20	21	22	23
24	25	26	27	28	29	30
31						

6	7
13	14

$$6 + 7 + 13 + 14 = 40$$

? Can we find the 4 numbers in the grid from just knowing this sum?

Let us use algebra. Consider a 2×2 grid. Let a represent the top left number. What are the other numbers in terms of a ?

a	$a + 1$
$a + 7$	$a + 8$

Adding all four numbers, the sum is $a + (a + 1) + (a + 7) + (a + 8) = 4a + 16$.

? Suppose you are told that the sum is 36. Can you find the 4 numbers in the grid?

- $4a + 16 = 36$
- $4a = 20$ (subtracting 16 from both sides)
- $a = 5$ (dividing both sides by 4)

Now that we have found a , we know that the other three numbers are $a + 1$, $a + 7$ and $a + 8$. Therefore, the grid must be the following:

5	6
12	13



? Create your own calendar trick. For instance, choose a grid of a different size and shape.

AUGUST 2025						
SUN	MON	TUE	WED	THU	FRI	SAT
					1	2
3	4	5	6	7	8	9
10	11	12	13	14	15	16
17	18	19	20	21	22	23
24	25	26	27	28	29	30
31						



2	3	4	5	6	7	8	9	10
12	13	14	15	16	17	18	19	20
22	23	24	25	26	27	28	29	30
32	33	34	35	36	37	38	39	40
42	43	44	45	46	47	48	49	50

Algebra Grids

In the following grid, shapes represent numbers. In each row, the last column is the sum of the values to its left. How do we find the values of the shapes?

■	■	■	27
●	●	■	19

$$\blacksquare + \blacksquare + \blacksquare = 27$$

$$\text{So, } \blacksquare = 9$$

$$\text{Now, } \bullet + \bullet + \blacksquare = 19$$

$$\bullet + \bullet + 9 = 19$$

$$2 \times \bullet + 9 = 19$$

$$\bullet = 5$$

? In the following grids, find the values of the shapes and fill in the empty squares:

■	■	●	27
●	●	■	21
●	■	●	

●	◆	◆	18
◆	●	●	15
◆	●	●	

6.5 The Largest Product

? Fill the digits 2, 3, and 5 in $\square \square \times \square$, using each digit once. What is the largest product possible?

Let us approach this problem systematically. There are six ways to place three digits:

- We can fill the first box with 2, 3 or 5.
- For each of these choices, we have 2 ways of filling the remaining 2 digits.
- The six options are 23×5 , 25×3 , 32×5 , 35×2 , 52×3 , 53×2 .

❓ How do we find the largest product among these six options?

We can group them in pairs where the multiplier is the same.

- 35×2 and 53×2
- 25×3 and 52×3
- 23×5 and 32×5

In each pair, the one with the larger multiplicand generates the larger product, so we can reduce the comparison to these three expressions.

- 53×2
- 52×3
- 32×5

It is clear that 52×3 is bigger than 53×2 , so we only need to compare 52×3 and 32×5 . Let us expand these.

- $32 \times 5 = (3 \times 10 \times 5) + (2 \times 5)$
- $52 \times 3 = (5 \times 10 \times 3) + (2 \times 3)$

The first terms in both expressions are the same. The second term shows that 32×5 is larger, and hence the largest of the six possible products we can form with 2, 3 and 5.

❓ In this case, we used the largest digit as the multiplier. The other two digits were arranged in decreasing order to form the multiplicand. Will this always be the case? Let us find out using algebra.

Suppose p , q , and r are the three digits such that $p < q < r$.

As before, we have six possible products, which we group by the multiplier:

- $qr \times p$, $rq \times p$
- $pr \times q$, $rp \times q$
- $pq \times r$, $qp \times r$

In each pair, the multiplicand with the larger tens digit forms the larger product. So we have three products to compare:

- $rq \times p$
- $rp \times q$
- $qp \times r$

Since $q > p$, we can see that $rp \times q$ is bigger than $rq \times p$. This leaves us with a comparison between $qp \times r$ and $rp \times q$. If we expand these, we get

- $qp \times r = (10 \times q \times r) + (p \times r)$
- $rp \times q = (10 \times r \times q) + (p \times q)$

Once again, the first term is the same in both expressions. Since $r > q$ the second term of the first expression is larger, so the largest product is $qp \times r$. This matches our earlier observation that the largest digit should be the multiplier and the other two digits should be arranged in decreasing order to form the multiplicand.

? Figure it Out

1. Fill the digits 1, 3, and 7 in $\square \square \times \square$ to make the largest product possible.
2. Fill the digits 3, 5, and 9 in $\square \square \times \square$ to make the largest product possible.

6.6 Decoding Divisibility Tricks

It is now Mukta's turn to show a mathematics trick to Shubham.

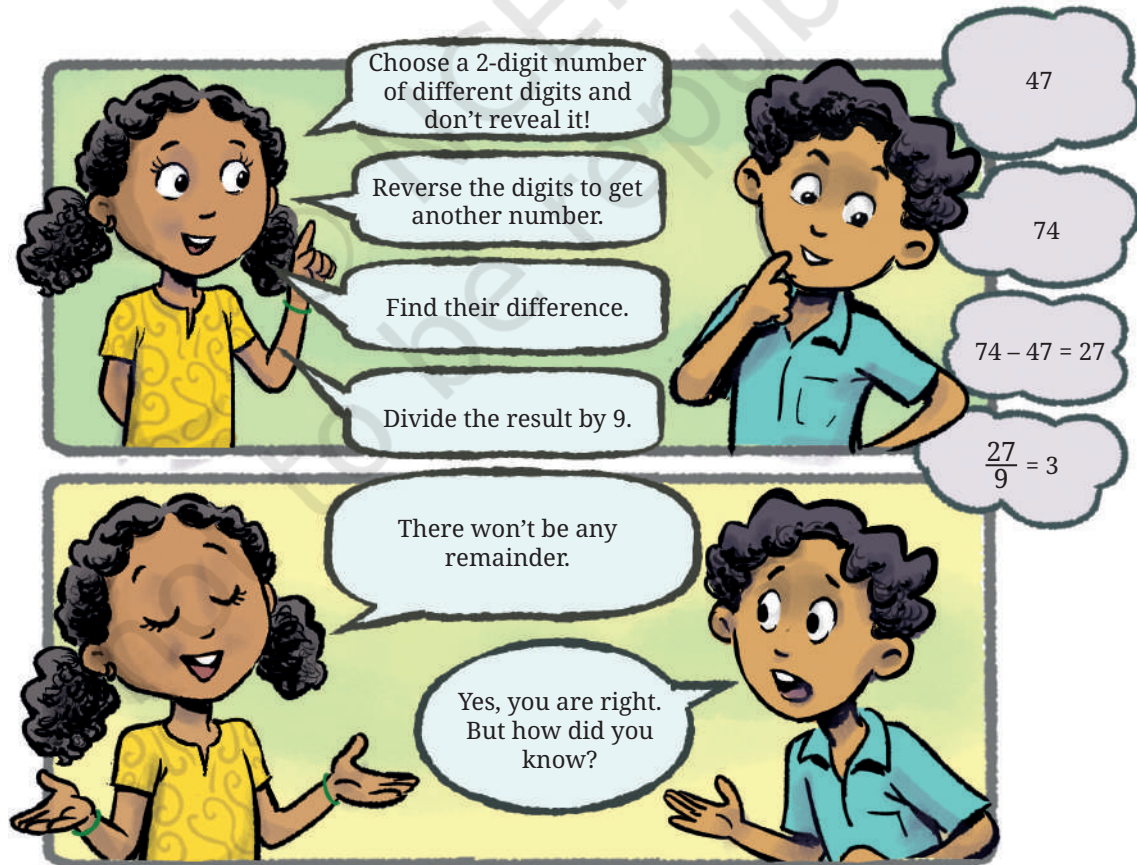

- ? If we choose other 2-digit numbers, and follow the steps, will there always be no remainder?

Let's try to understand how Mukta's trick works.

Suppose the two-digit number is ab . When it is reversed, the new number is ba .

- If $b > a$, then $ba > ab$. So, the difference is

$$\begin{aligned} &(10b + a) - (10a + b) \\ &= 10b - b - 10a + a \\ &= 9b - 9a = 9(b - a). \end{aligned}$$

The difference is divisible by 9.

- ? Can you work out what happens if $a > b$?

? Figure it Out

1. In the trick given above, what is the quotient when you divide by 9? Is there a relationship between the two numbers and the quotient?
2. In the trick given above, instead of finding the difference of the two 2-digit numbers, find their sum. What will happen? For example:
 - We start with 31. After reversing we get 13. Adding 31 and 13, we get 44.
 - We start with 28. After reversing we get 82. Adding 28 and 82, we get 110.
 - We start with 12. After reversing we get 21. Adding 12 and 21, we get 33.

Observe that all these numbers are divisible by 11. Is this always true? Can we justify this claim using algebra?

3. Consider any 3-digit number, say abc ($100a + 10b + c$). Make two other 3-digit numbers from these digits by cycling these digits around, yielding bca and cab . Now add the three numbers. Using algebra, justify that the sum is always divisible by 37. Will it also always be divisible by 3? [Hint: Look at some multiples of 37.]
4. Consider any 3-digit number, say abc . Make it a 6-digit number by repeating the digits, that is $abcabc$. Divide this number by 7, then by 11, and finally by 13. What do you get? Try this with other numbers. Figure out why it works. [Hint: Multiply 7, 11 and 13.]
5. There are 3 shrines, each with a magical pond in the front. If anyone dips flowers into these magical ponds, the number of flowers doubles. A person has some flowers. He dips them all in the first pond and then places some flowers in shrine 1. Next, he dips the remaining flowers in the second pond and places

some flowers in shrine 2. Finally, he dips the remaining flowers in the third pond and then places them all in shrine 3. If he placed an equal number of flowers in each shrine, how many flowers did he start with? How many flowers did he place in each shrine?

6. A farm has some horses and hens. The total number of heads of these animals is 55 and the total number of legs is 150. How many horses and how many hens are on the farm?

Can you solve this without letter-numbers?

[**Hint:** If all the 55 animals were hens, then how many legs would there be? Using the difference between this number and 150, can you find the number of horses?]

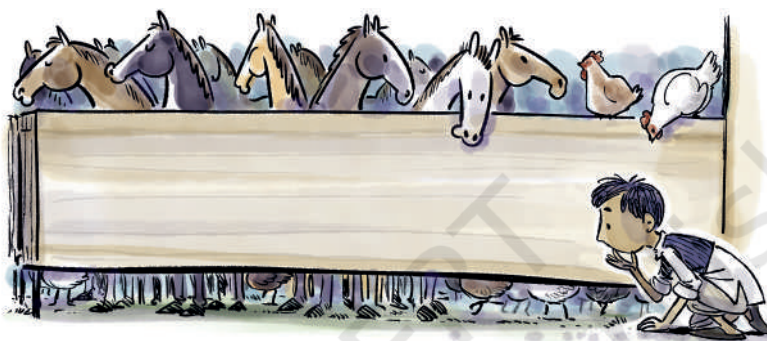

7. A mother is 5 times her daughter's age. In 6 years' time, the mother will be 3 times her daughter's age. How old is the daughter now?
8. Two friends, Gauri and Naina, are cowherds. One day, they pass each other on the road with their cows. Gauri says to Naina, "You have twice as many cows as I do". Naina says, "That's true, but if I gave you three of my cows, we would each have the same number of cows". How many cows do Gauri and Naina have?
9. I run a small dosa cart and my expenses are as follows:
- Rent for the dosa cart is ₹5000 per day.
 - The cost of making one dosa (including all the ingredients and fuel) is ₹10.
- (i) If I can sell 100 dosas a day, what should be the selling price of my dosa to make a profit of ₹2000?
- (ii) If my customers are willing to pay only ₹50 for a dosa, how many dosas should I aim to sell in a day to make a profit of ₹2000?
10. Evaluate the following sequence of fractions:

$$\frac{1}{3}, \frac{(1+3)}{(5+7)}, \frac{(1+3+5)}{(7+9+11)}$$

What do you observe? Can you explain why this happens?

[**Hint:** Recall what you know about the sum of the first n odd numbers.]

11. Karim and the Genie

Karim was taking a nap under a tree. He had a dream about a magical lamp and a genie. He heard a voice saying, "I have come to serve you, Oh master". He woke up and to his surprise, it was a genie!

"Do you want to make money?", asked the genie. Karim nodded dumbly in bewilderment. The genie continued, "Do you see the banyan tree over there? All you have to do is go around it once. The money in your pocket will double".

Karim immediately started towards the tree, only to be stopped by the genie. "One moment!", said the genie. "Since I am bringing you great riches, you should share some of your gains with me. You must give me 8 coins each time you go around the tree."

Thinking that was a trifling amount, Karim readily agreed.

He went around the tree once. Just as the genie had said, the number of coins in his pocket doubled! He gave 8 coins to the genie. He made another round. Again the number of coins doubled. He gave 8 more coins to the genie. He went around the tree for the third time. The number of coins doubled again, but to his horror, he was left with only 8 coins, exactly the number of coins he owed the genie!

As Karim began to wonder how the genie tricked him, the genie let out a loud laugh and disappeared.

- (i) How many coins did Karim initially have?
- (ii) For what cost per round should Karim agree to the deal, if he wants to increase the number of coins he has?
- (iii) Through its magical powers, the genie knows the number of coins that Karim has. How should the genie set the cost per round so that it gets all of Karim's coins?



Math
Talk

SUMMARY

- Algebra is very useful in modeling and understanding numerical scenarios. Because of this, it occurs in almost all areas of mathematics, science and beyond.
- Algebra is an indispensable tool in justifying mathematical statements.
- We applied algebra to analyse 'Think of a Number' tricks, number pyramids, grids, ways of forming numbers using given digits to maximise certain products, divisibility tricks, and various other problems.

7

AREA



0889CH07

7.1 Rectangle and Squares

- ? How many different ways can you divide a square into 4 parts of equal area?

One can actually think of infinitely many such ways! Consider a division, such as —

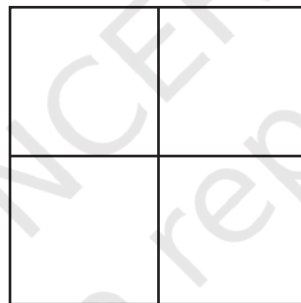

and alter each part as follows.

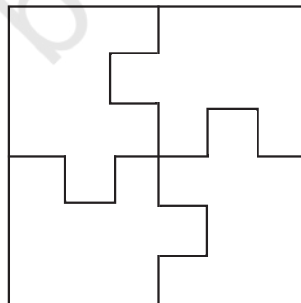

In each part, the area is compressed along one edge and expanded along another edge. If both the compression and expansion are of the same magnitude, then all 4 parts still have the same area!

- ? Try to think of different creative ways to divide a square into 4 parts of equal area.



You might have seen the rangoli art form, in which regions of different shapes are beautifully coloured using rangoli powder.



- ? Which of these rectangles requires more rangoli powder to be coloured, if the colouring is done evenly?

We can answer this by counting the number of non-overlapping unit squares (squares of sidelength 1 cm in this case) that can be packed into each of the rectangles.

Clearly, the rectangle having sidelengths 7 cm and 4 cm contains $7 \times 4 = 28$ unit squares, and the rectangle having sidelengths 8 cm and 3 cm contains $8 \times 3 = 24$ unit squares.

Thus, the rectangle of sidelengths 7 cm and 4 cm requires more powder to be coloured.

Recall that we measure the area of a region by finding the number of unit squares (which can also be a fraction) whose area equals that of the given region.

We have seen that the number of unit squares contained in a rectangle is given by the product of its length and width —

$$\text{Area of a rectangle} = \text{length} \times \text{width}.$$

The areas of the rectangles as seen in the previous problem are generally written as 28 sq. cm and 24 sq. cm, or as 28 cm^2 and 24 cm^2 .

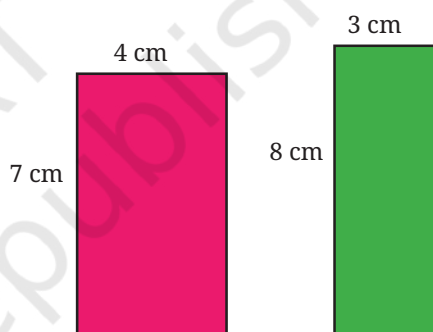

? What is the area of each triangle in this rectangle?

We have seen that the diagonal of a rectangle divides it into two congruent triangles. So, the area of each triangle is half the area of the rectangle.

In terms of unit squares, half the area fills exactly half the number of unit squares.

So the area of each triangle is $\frac{1}{2} \times 7 \times 4 = 14 \text{ cm}^2$.

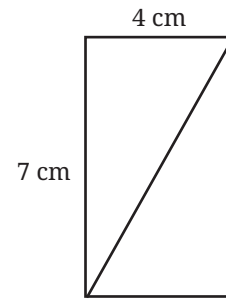

Why Can't Perimeter be a Measure of Area?

? Why do we count the number of unit squares to assign measures for area? Couldn't we have just used the perimeter of a region, i.e., the length of its boundary as a measure of its area?

? If two regions have the same perimeter, can't we conclude that they have the same area? Or, if one region has a larger perimeter than another region, can't we conclude that it also has a larger area?

The perimeter of a region is not indicative of its area. The reason is that regions can have the same perimeter but different areas, and vice versa. We can even find two regions, Region 1 and Region 2, such that

$$\begin{aligned} \text{Perimeter of Region 1} &> \text{Perimeter of Region 2, but} \\ \text{Area of Region 1} &< \text{Area of Region 2.} \end{aligned}$$

? Find two rectangles that are examples of such regions. If needed, use a grid paper (given at the end of the book) for this.

? Also give an example of two regions of other shapes, where the region with the larger perimeter has the smaller area! This property should be visually clear in your example.



? Figure it Out

1. Identify the missing sidelengths.

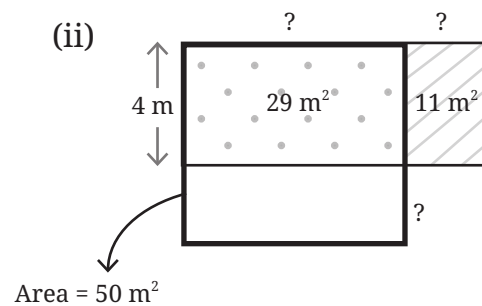
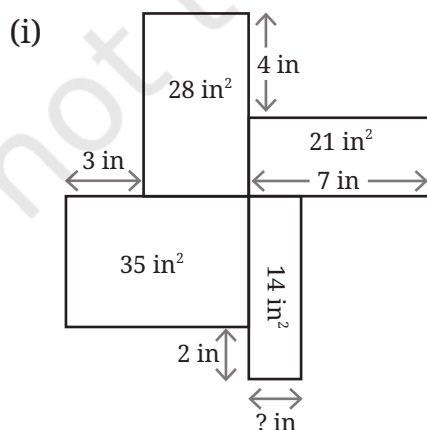

2. The figure shows a path (the shaded portion) laid around a rectangular park EFGH.

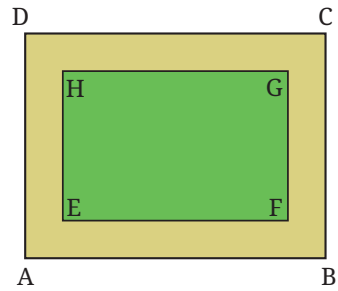

- (i) What measurements do you need to find the area of the path? Once you identify the lengths to be measured, assign possible values of your choice to these measurements and find the area of the path. Give a formula for the area.

An example of a formula — *Area of a rectangle = length × width.*

[Hint: There is a relation between the areas of EFGH, the path, and ABCD.]

- (ii) If the width of the path along each side is given, can you find its area? If not, what other measurements do you need? Assign values of your choice to these measurements and find the area of the path. Give a formula for the area using these measurements.

[Hint: Break the path into rectangles.]

- (iii) Does the area of the path change when the outer rectangle is moved while keeping the inner rectangular park EFGH inside it, as shown?

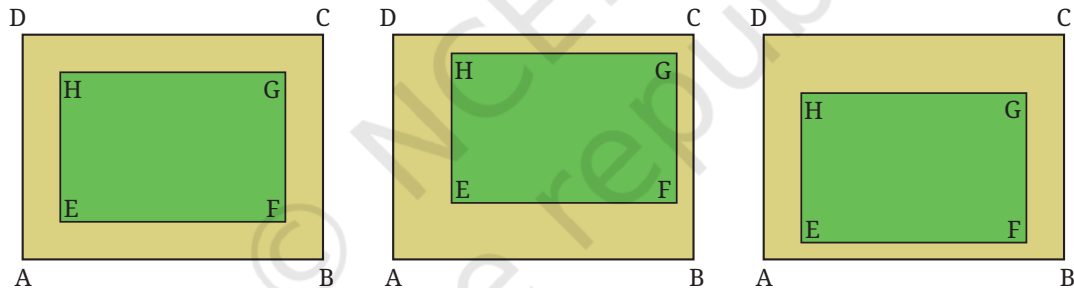

3. The figure shows a plot with sides 14m and 12m, and with a crosspath. What other measurements do you need to find the area of the crosspath? Once you identify the lengths to be measured, assign some possible values of your choice and find the area of the path. Give a formula for the area based on the measurements you choose.

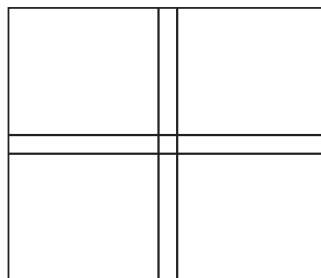

4. Find the area of the spiral tube shown in the figure. The tube has the same width throughout.

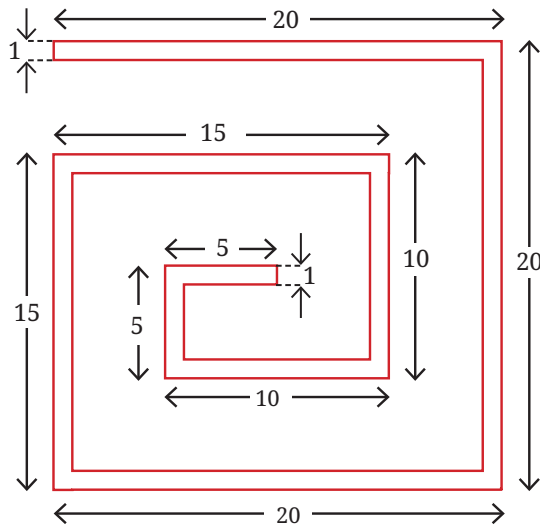

[Hint: There are different ways of finding the area. Here is one method.]

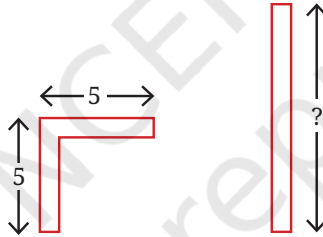

What should be the length of the straight tube if it is to have the same area as the bent tube on the left?

5. In this figure, if the sidelength of the square is doubled, what is the increase in the areas of the regions 1, 2 and 3? Give reasons.
6. Divide a square into 4 parts by drawing two perpendicular lines inside the square as shown in the figure.

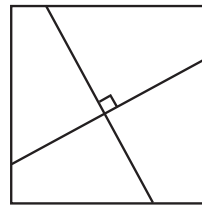
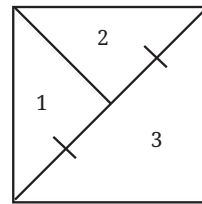

Rearrange the pieces to get a larger square, with a hole inside.

You can try this activity by constructing the square using cardboard, thick chart paper, or similar materials.

Math Talk

Triangles

- ? In the given figure, which triangle has a greater area: $\triangle XDC$ or $\triangle YDC$, if both the rectangles are identical?

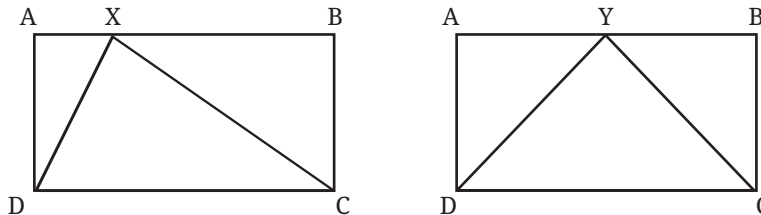

- ? In the given figure, which triangle has a greater area: $\triangle XDC$ or $\triangle YBC$, if both the rectangles are identical?

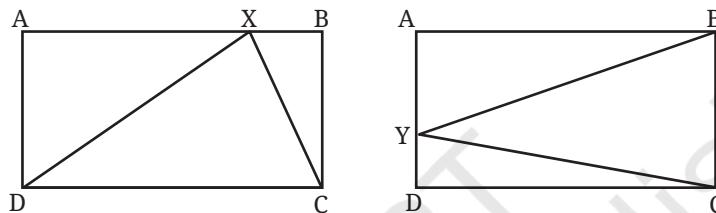

In each case, by dropping the altitudes from X and Y, it becomes clear that each triangle has exactly half the area of the rectangle ABCD.

- ? Find the area of $\triangle XDC$.

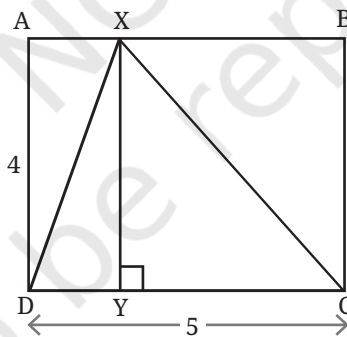
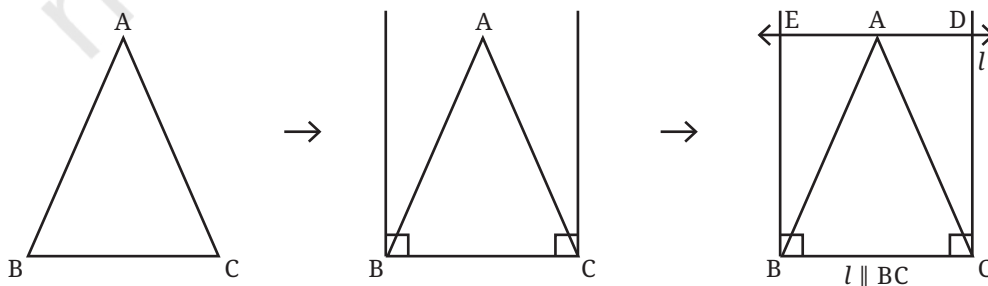

Fig. 7.1

- ? To find the area of a triangle, what measurements do we need?

We need the sidelengths of the outer rectangle, as in Fig. 7.1.

- ? How do we get the outer rectangle from the given triangle?



BCDE is a rectangle (how?). Let us take its sidelengths to be height and base. Then,

$$\text{Area} (\Delta ABC) = \frac{1}{2} \times \text{base} \times \text{height}$$

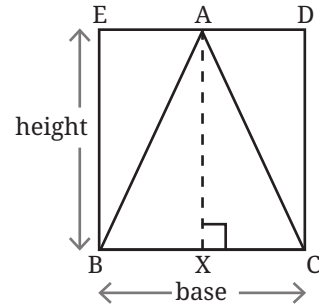

Since BXAE is a rectangle (how?), the height of the rectangle is the same as the height of the triangle.

Thus, if the height and the base of a triangle are known, we can find its area.

$$\text{Area of a triangle} = \frac{1}{2} \times \text{base} \times \text{height}.$$

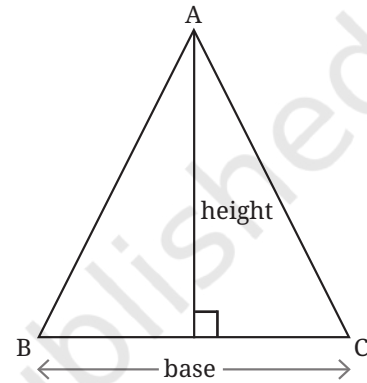

- ? Will this formula hold for the kind of triangle, around which we cannot draw a rectangle with BC as the base?

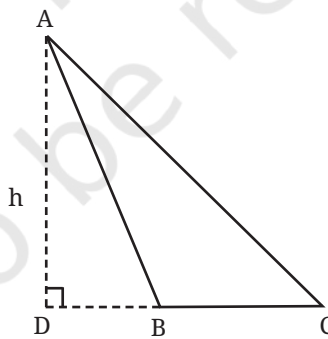

Here is one way to look at it. The area of ΔABC is the difference of the areas of ΔADC and ΔADB , each of which can be enclosed in a rectangle, as in Fig. 7.1.

$$\begin{aligned} \text{Area} (\Delta ABC) &= \frac{1}{2} \times h \times DC - \frac{1}{2} \times h \times DB \\ &= \frac{1}{2} \times h (DC - DB) \\ &= \frac{1}{2} \times h \times BC \end{aligned}$$

Thus, the area formula holds for all types of triangles.

Some Applications of the Area Formula

? Find BY.

BY can be found using the formula for the area of a triangle.

What is Area ($\triangle ABC$)?

$$\text{Area } (\triangle ABC) = \frac{1}{2} \times AX \times BC = \frac{15}{2} \text{ sq. units.}$$

The area of the triangle can also be written as

$$\text{Area } (\triangle ABC) = \frac{1}{2} \times BY \times AC = \frac{1}{2} \times 4 \times BY = 2 BY.$$

Thus,

$$2 BY = \frac{15}{2}.$$

$$\text{So, } BY = \frac{15}{4} = 3.75 \text{ units.}$$

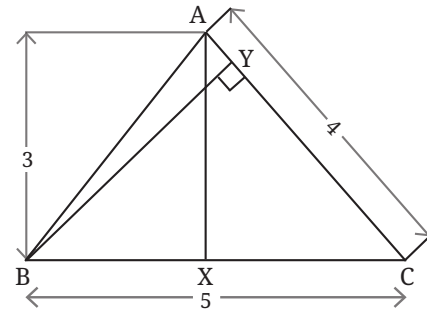

? Are the 4 triangles obtained by drawing the diagonals of a rectangle (regions 1–4 in the figure) of equal areas?

Clearly, the triangles 1–4 are not four congruent triangles.

To compare their areas, let us consider any two adjacent triangles, say 1 and 2.

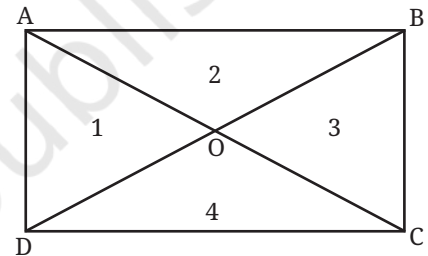

Since the area of a triangle depends on its height and the base, let us consider suitable height-base pairs in each of the triangles. If OD and OB are taken as the bases, then we see that both triangles have the same altitude!

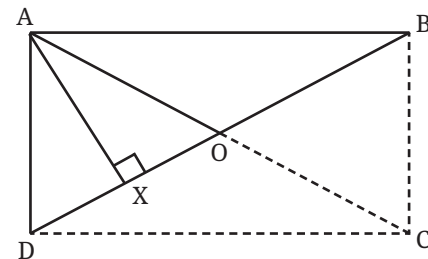

We also have $OB = OD$, since the diagonals of a rectangle bisect each other. So, the triangles 1 and 2 have equal areas.

Arguing this way, we can show that all four triangles have equal areas.

From this problem, we can make the following general statement.

In a triangle, the line joining a vertex to the midpoint of its opposite side divides the triangle into two triangles of equal areas.

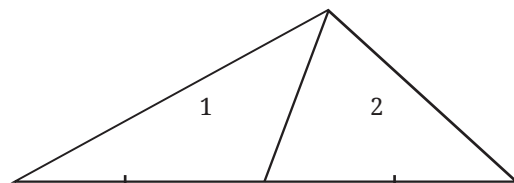

Triangles 1 and 2 have equal areas as they have the same measures for height and base

Triangles between Parallel Lines with a Common Base

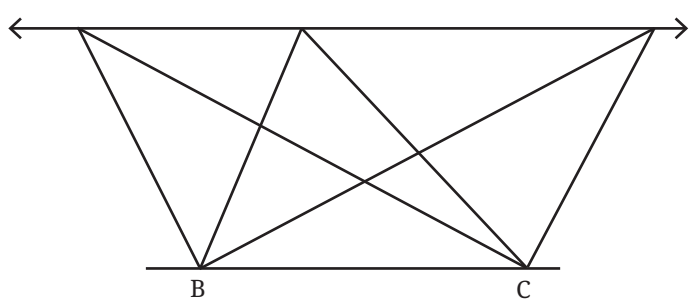

? Line $l \parallel BC$. Consider the different triangles that have BC as their base, and with their third vertex lying anywhere on l .

- (i) Which of these triangles has the maximum area, and which has the minimum area?
- (ii) Which of these triangles has the maximum perimeter, and which has the minimum perimeter?

Here, we will only show how to find the triangle with the minimum perimeter, and leave the other questions as exercises.

Intuition might suggest that the triangle with the minimum perimeter can be obtained by constructing the perpendicular bisector of BC .

But how do we justify that this triangle has the least perimeter among all the triangles?

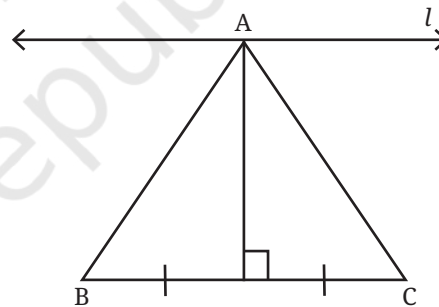

Firstly, note that in all these triangles, BC is a common side. Therefore, it is enough to consider the sum of the other two sides.

Let us imagine the line l as a mirror. Then we get a reflection of all the points and lines below it.

While studying the properties of a plane mirror, we experimentally observed that the distance of the image behind the mirror is the same as the distance of the object (that creates the image) in front of the mirror. This law can be used to locate the reflections of the points lying below the line l .

? What can we say about the lengths of AB and its reflection AB' ?

Since $\triangle AXB \cong \triangle AXB'$, $AB = AB'$.

Similarly, $AC = AC'$.

Therefore, the length of the path $B \rightarrow A \rightarrow C$ is the same as the length of the path $B \rightarrow A \rightarrow C'$.

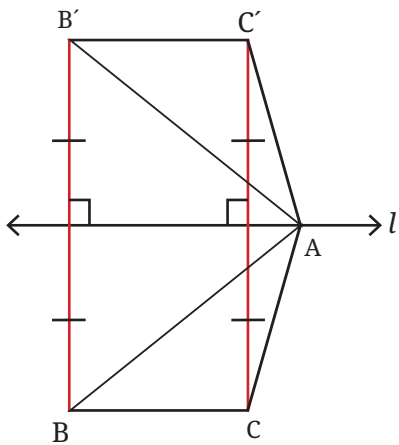

This is true no matter where point A is on line l .

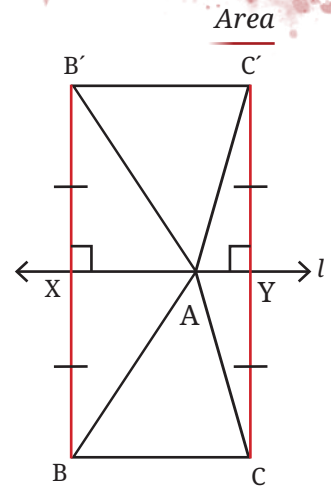

So, finding point A that gives the shortest possible path $B \rightarrow A \rightarrow C$ is the same as finding a point A that gives the shortest possible path $B \rightarrow A \rightarrow C'$.

But the solution to the latter problem is clear — choose A on the straight line BC' , since BC' is the shortest possible path from B to C' .

Therefore, this triangle $\triangle ABC$ has the minimum perimeter.

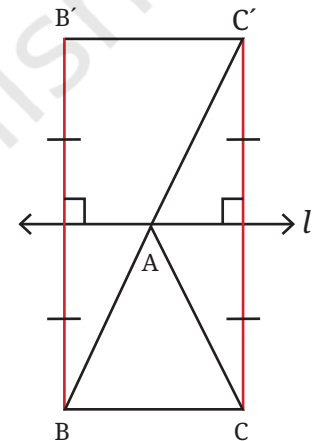

? Analyse whether A lies on the perpendicular bisector of BC .

? **Figure it Out**

1. Find the areas of the following triangles:

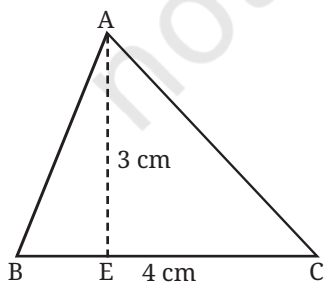

(i)

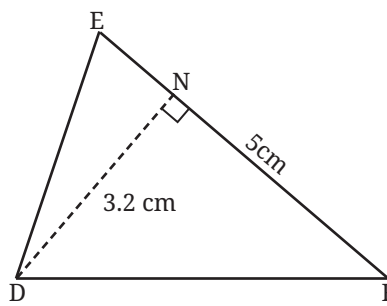

(ii)

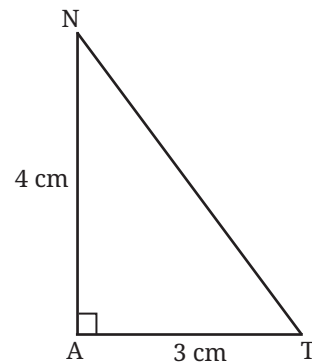

(iii)



2. Find the length of the altitude BY.

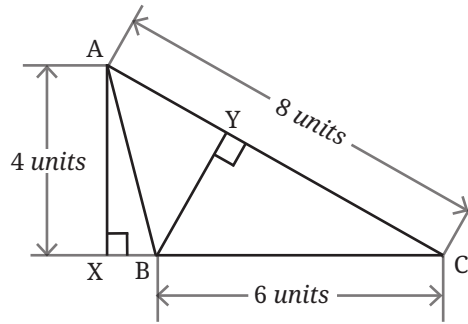

3. Find the area of $\triangle SUB$, given that it is isosceles, SE is perpendicular to UB, and the area of $\triangle SEB$ is 24 sq. units.

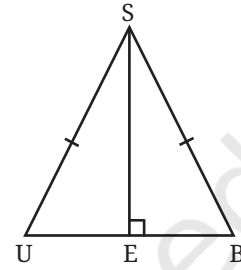

In the *Śulba-Sūtras*, which are ancient Indian geometric texts that deal with the construction of altars, we can find many interesting problems on the topic of areas. When altars are built, they must have the exact prescribed shape and area. This gives rise to problems of the kind where one has to transform a given shape into another of the same area. The *Śulba-Sūtras* give solutions to many such problems.

Such problems are also posed and solved in Euclid's Elements.

Here are two problems of this kind.

4. [*Śulba-Sūtras*] Give a method to transform a rectangle into a triangle of equal area.
5. [*Śulba-Sūtras*] Give a method to transform a triangle into a rectangle of equal area.
6. ABCD, BCEF, and BFGH are identical squares.
 - (i) If the area of the red region is 49 sq. units, then what is the area of the blue region?
 - (ii) In another version of this figure, if the total area enclosed by the blue and red regions is 180 sq. units, then what is the area of each square?

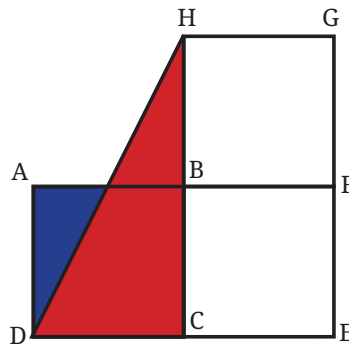

7. If M and N are the midpoints of XY and XZ, what fraction of the area of $\triangle XYZ$ is the area of $\triangle XMN$? [Hint: Join NY]

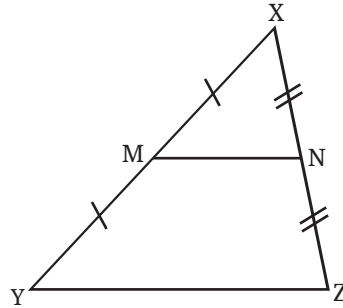

8. Gopal needs to carry water from the river to his water tank. He starts from his house. What is the shortest path he can take from his house to the river and then to the water tank? Roughly recreate the map in your notebook and trace the shortest path.

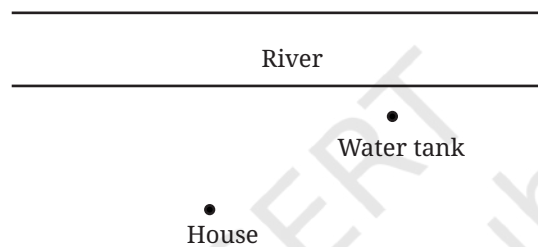

Area of any Polygon

- ? How do we find the area of this quadrilateral? What measurements do we need for this?

If we join BD, the quadrilateral ABCD gets divided into two triangles. By finding their areas, we can find the area of ABCD.

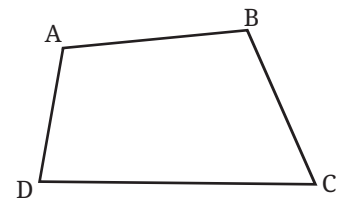

- ? How do we find the area of this pentagon?

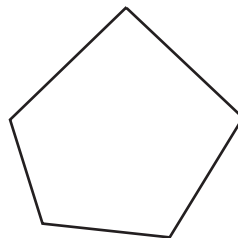

- ? Can any polygon be divided into triangles?

It can be seen that any polygon can be divided into triangles. Thus, by knowing how to compute the area of a triangle, we can find the area of any polygon.

? Figure it Out

1. Find the area of the quadrilateral ABCD given that $AC = 22$ cm, $BM = 3$ cm, $DN = 3$ cm, BM is perpendicular to AC , and DN is perpendicular to AC .

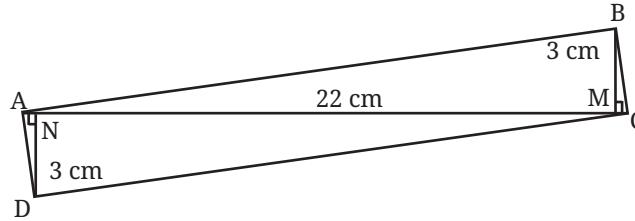

2. Find the area of the shaded region given that ABCD is a rectangle.

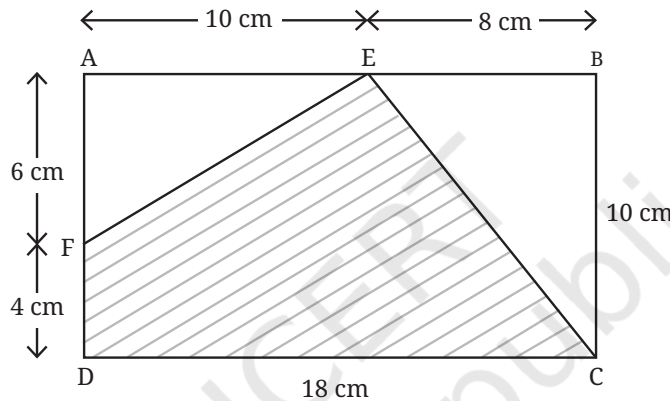

3. What measurements would you need to find the area of a regular hexagon?
4. What fraction of the total area of the rectangle is the area of the blue region?



5. Give a method to obtain a quadrilateral whose area is half that of a given quadrilateral.



One can derive special formulae to find the areas of a parallelogram, rhombus and trapezium.

Parallelogram

We can derive a special formula for the area of a parallelogram by converting it into a rectangle of equal area.

- ? Give a method to convert a parallelogram into a rectangle of equal area. You can try this using a cut-out of a parallelogram.

Construct AX perpendicular to CD — represented in short as $AX \perp CD$. We call this a **height** of the parallelogram. Cut the parallelogram into $\triangle AXD$ and trapezium $ABCX$.

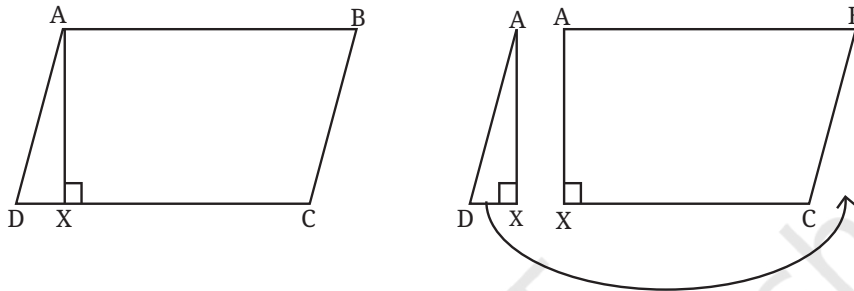

- ? Can $\triangle AXD$ and $ABCX$ fit together, as shown in the figure, to get a rectangle?

One simple way to check this is to identify the triangle that can complete $ABCX$ to a rectangle, and then check if this triangle is congruent to $\triangle AXD$.

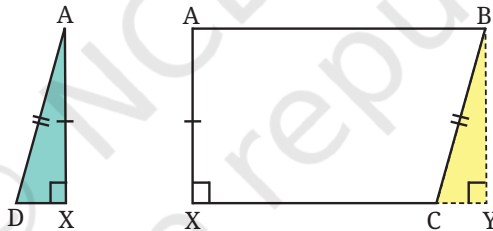

Observe that $\angle X = 90^\circ$, and so $\angle A = 90^\circ$, since $AB \parallel XC$. We need another right angle to get a rectangle (what about the fourth angle?). To get the third right angle, extend XC to the right and then construct a line perpendicular to XC that passes through B . The $\triangle BYC$ completes $ABCX$ to a rectangle. Is $\triangle AXD$ congruent to it?

$$BY = AX \text{ (since } ABYX \text{ is a rectangle)}$$

$$\angle BYC = \angle AXD = 90^\circ$$

$$BC = AD \text{ (since } ABCD \text{ is a parallelogram)}$$

So, by the RHS congruency criterion, $\triangle BYC \cong \triangle AXD$. Thus, $\triangle AXD$ will fit exactly over the region occupied by $\triangle BYC$, and convert the parallelogram into a rectangle.

The process of cutting a figure into pieces and rearranging them to get a different figure of equal area is called **dissection**.

? How do we find the area of a parallelogram by dissecting it into a rectangle?

We have

Area of the parallelogram ABCD = Area of the rectangle ABYX.

Area of the rectangle ABYX = AX × XY.

AX is the height of the parallelogram.

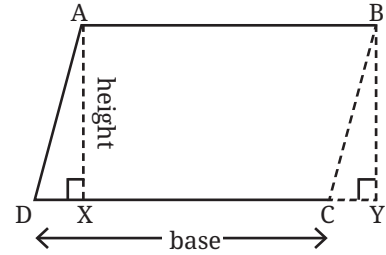

? Is there a relation between XY and DC?

Since $DX = CY$, we get $DC = XY$ by adding the common part XC to DX and CY . Since DC is the base of the parallelogram, we get

Area of the parallelogram = base × height.

? Can the area of the parallelogram be determined by taking another side as the base and its corresponding height?

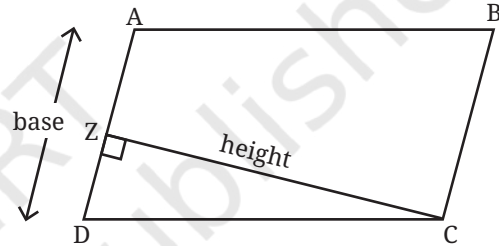

? Can the parallelogram be cut along CZ and rearranged to form a rectangle?

It can be seen that this is indeed possible, and so any side and its corresponding height can be used to find the area of a parallelogram.

? **Figure it Out**

1. Observe the parallelograms in the figure below.

- (i) What can we say about the areas of all these parallelograms?
- (ii) What can we say about their perimeters? Which figure appears to have the maximum perimeter, and which has the minimum perimeter?

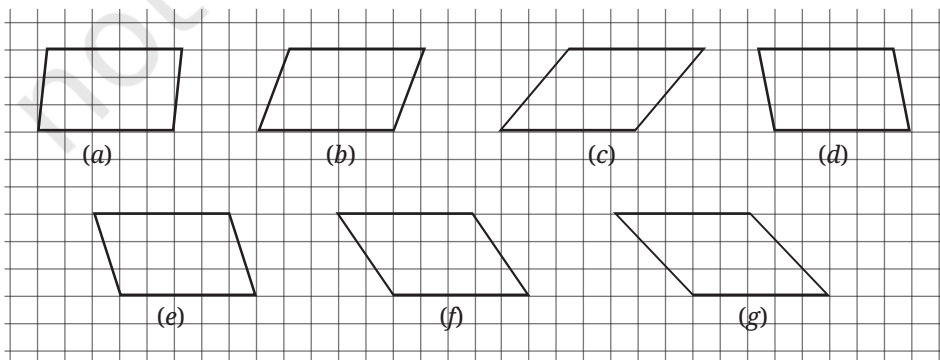

2. Find the areas of the following parallelograms:

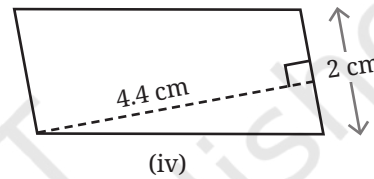
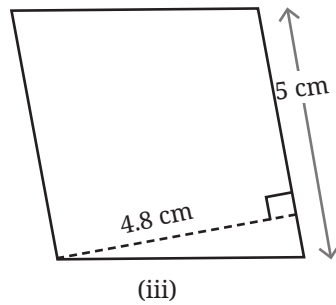
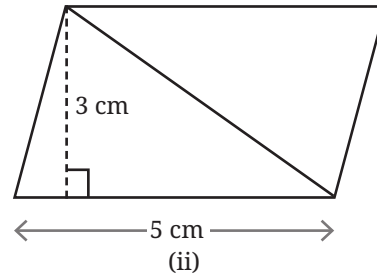
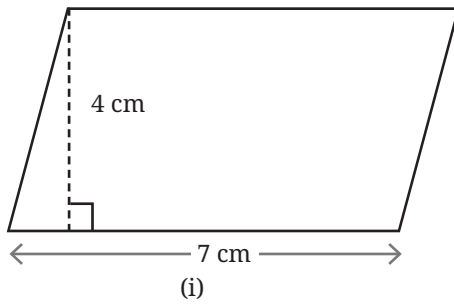

3. Find QN.

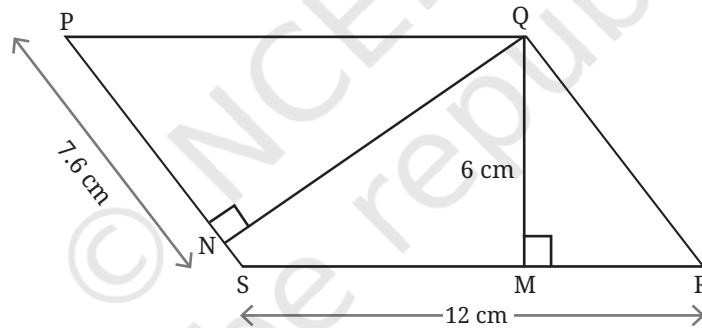

4. Consider a rectangle and a parallelogram of the same sidelengths: 5 cm and 4 cm. Which has the greater area? [Hint: Imagine constructing them on the same base.]

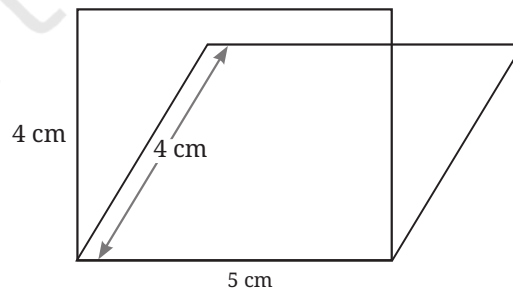

5. Give a method to obtain a rectangle whose area is twice that of a given triangle. What are the different methods that you can think of?

- [Śulba-Sūtras] Give a method to obtain a rectangle of the same area as a given triangle.
- [Śulba-Sūtras] An isosceles triangle can be converted into a rectangle by dissection in a simpler way. Can you find out how to do it?

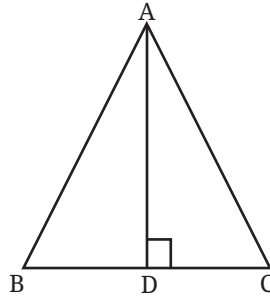

[Hint: Show that triangles $\triangle ADB$ and $\triangle ADC$ can be made into halves of a rectangle. Figure out how they should be assembled to get a rectangle. Use cut-outs if necessary.]

- [Śulba-Sūtras] Give a method to convert a rectangle into an isosceles triangle by dissection.
- Which has greater area—an equilateral triangle or a square of the same sidelength as the triangle? Which has greater area—two identical equilateral triangles together or a square of the same sidelength as the triangle? Give reasons.

Rhombus

Since a rhombus is a parallelogram, the area formula for a parallelogram holds for a rhombus as well. However, the additional properties of a rhombus give us another method to transform a rhombus into a rectangle of the same area by dissection. This method occurs in one of the *Śulba-Sūtras*.

 Try working this out!

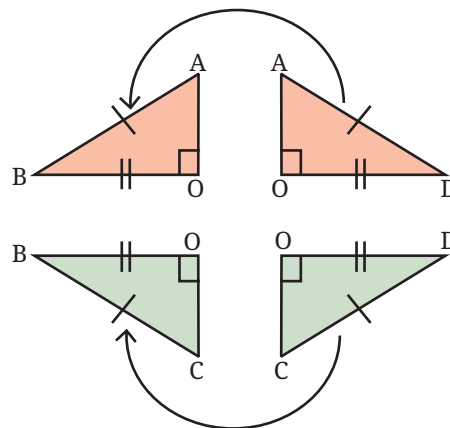
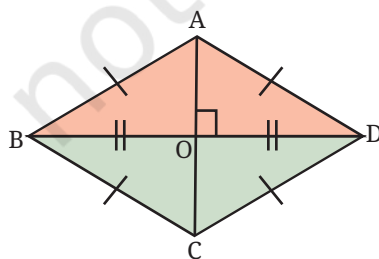

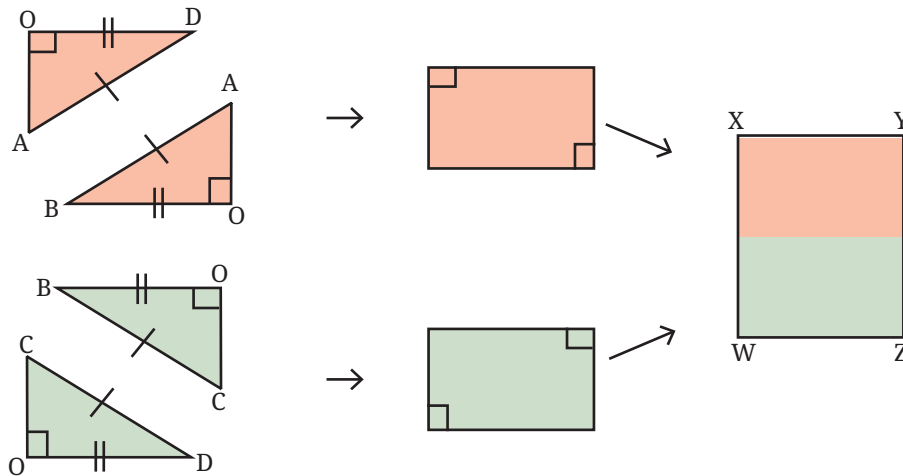

Since ABCD is a rhombus, all its sides have equal length, and the diagonals are perpendicular bisectors of each other. Therefore, $\triangle ABD$ and $\triangle CBD$ are isosceles triangles. Each of them can be transformed into a rectangle of equal area, and the two rectangles can then be joined to form a single rectangle. This rectangle, say WXYZ, has the same area as the rhombus ABCD.

? What are the sidelengths of the rectangle WXYZ?

From the dissection, we can see that

$$\begin{aligned} XW &= \text{length of the diagonal } AC, \text{ and} \\ WZ &= \text{half the length of the other diagonal } BD. \end{aligned}$$

Thus, we have

$$\begin{aligned} \text{Area of rhombus } ABCD &= \text{Area of rectangle } WXYZ \\ &= XW \times WZ \\ &= AC \times \frac{BD}{2} \\ &= \frac{1}{2} \times AC \times BD \end{aligned}$$

Therefore,

$$\text{Area of a rhombus} = \frac{1}{2} \times \text{product of diagonals.}$$

? Area of rhombus ABCD can also be determined by finding the areas of $\triangle ADB$ and $\triangle CDB$. What formula does this give us?

Since the diagonals are perpendicular to each other, we have

$$\text{Area}(\triangle ADB) = \frac{1}{2} \times AO \times BD, \text{ and}$$

$$\text{Area}(\triangle CDB) = \frac{1}{2} \times CO \times BD, \text{ and}$$

$$\text{Area of rhombus } ABCD = \text{Area}(\triangle ADB) + \text{Area}(\triangle CDB).$$

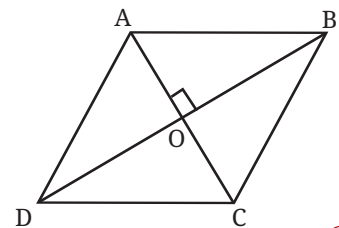

- ? Simplify the expression to show that we get the same formula for the area of a rhombus in terms of its diagonals.

Trapezium

- ? Find the areas of the following trapeziums by breaking them into figures whose areas can be computed.

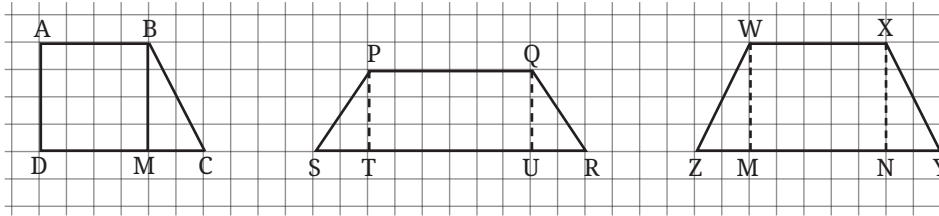

One way of finding the area of a trapezium is by breaking it into a rectangle and triangles.

- ? Consider a trapezium WXYZ with $WX \parallel ZY$. Find its area.

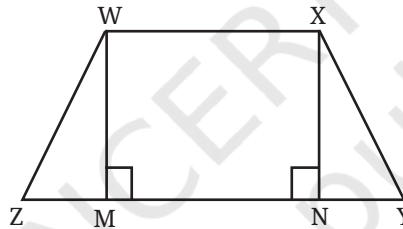

Construct $WM \perp ZY$, and $XN \perp ZY$ (WM and XN perpendicular to ZY).

- ? Is WXNM a rectangle?

$\angle MWX = \angle NXW = 90^\circ$, since $WX \parallel ZY$ and the interior angles on the same side of a transversal (WM and XN) add up to 180° . Therefore, WXNM is a rectangle.

We have

$$\begin{aligned} \text{Area } WXYZ &= \text{Area } (\Delta WMZ) + \text{Area } WXNM + \text{Area } (\Delta XNY) \\ &= \frac{1}{2} \times MZ \times WM + WX \times WM + \frac{1}{2} \times NY \times XN \end{aligned}$$

Let us assign letter numbers to the lengths that we need to find the area of the trapezium. Let $MZ = x$, $WM = XN = h$, $WX = a$, $NY = y$.

So we get

$$\begin{aligned} \text{Area } WXYZ &= \frac{1}{2} hx + ha + \frac{1}{2} hy \\ &= h\left(\frac{1}{2}x + a + \frac{1}{2}y\right) \\ &= h\left(\frac{x+y+2a}{2}\right) \\ &= \frac{1}{2} h(x+y+2a). \end{aligned}$$

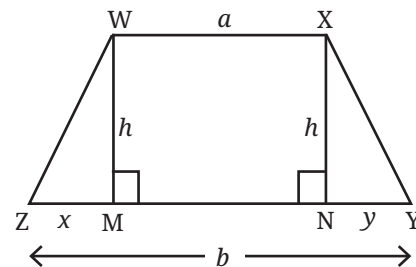

We have taken the length of one of the parallel sides as a . Let b be the length of the other parallel side.

Can the area of the trapezium be expressed in terms of a , b and h ?

To replace $x + y$ in the area expression with a and b , observe that $b = x + y + a$. Subtracting a from both sides, we get

$$x + y = b - a.$$

Using this, we get

$$\begin{aligned} \text{Area WXYZ} &= \frac{1}{2} h(b - a + 2a) \\ &= \frac{1}{2} h(a + b). \end{aligned}$$

Therefore,

$$\text{Area of a trapezium} = \frac{1}{2} \times \text{height} \times \text{sum of the parallel sides.}$$

? Will this formula hold for a trapezium that looks like this?

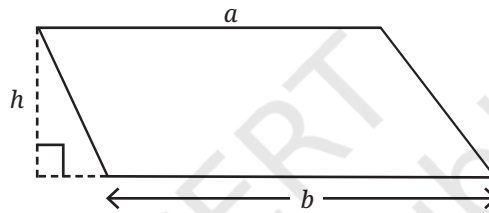

There are different ways of approaching this, which are sketched below. Complete the arguments.

Approach 1: Rectangle and Triangles

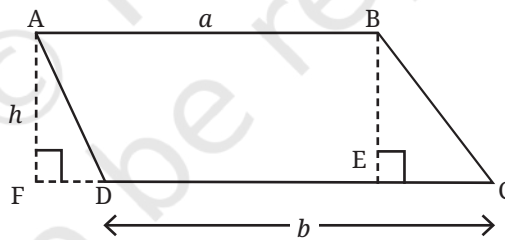

$$\text{Area ABCD} = \text{Area ABED} + \text{Area } \triangle BEC$$

$$\text{Area ABED} = \text{Area ABEF} - \text{Area } \triangle AFD$$

Approach 2: Parallelogram and Triangle

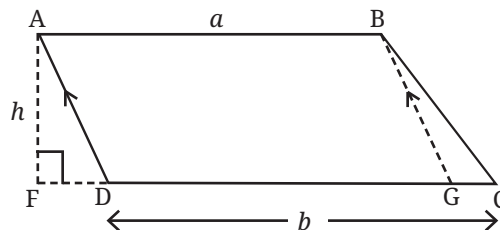

Draw $BG \parallel AD$

? Will Approach 2 work for any type of trapezium?

Finding the Area Using Two Copies of the Trapezium

There is another interesting way of finding the area of a trapezium. Consider two copies of the given trapezium in which $AB \parallel CD$. Rotate the second copy as shown.

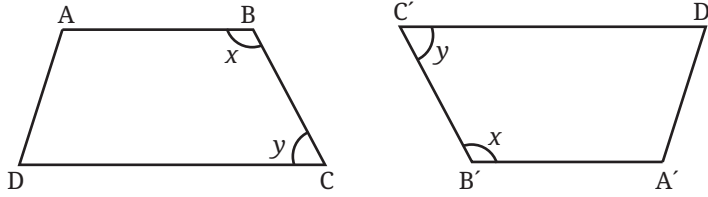

- ? What figure will we get when the two trapeziums are joined along BC? The possibilities are either a 6-sided figure or a 4-sided figure (quadrilateral).

Possibilities

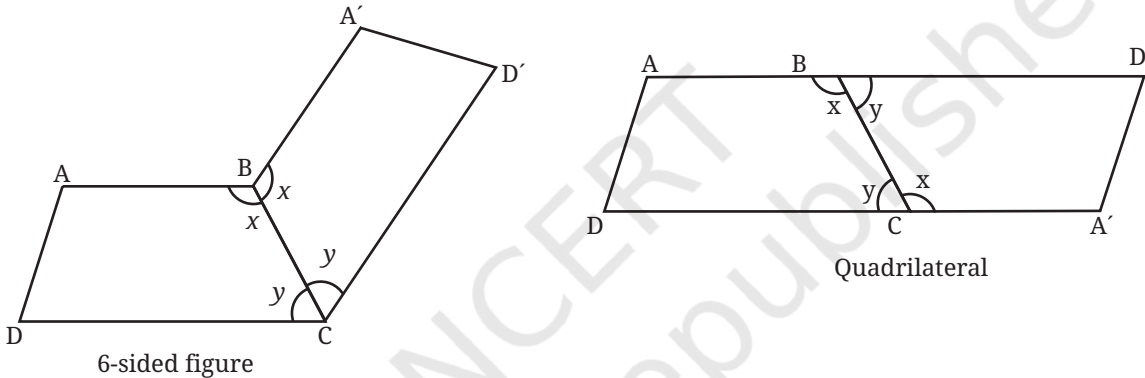

We can rule out the first possibility by looking at the sum of angles x and y . Since $AB \parallel CD$, we have $x + y = 180$, since they are internal angles along the same side of the transversal (BC). So ABD' and $A'CD$ are straight lines. Therefore, the resulting figure is a quadrilateral.

- ? What type of a quadrilateral is this? Let us look at the other two angles of the trapezium.

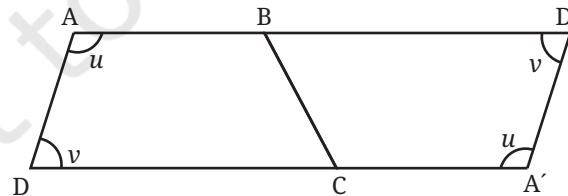

We have $u + v = 180$. Therefore, $AD \parallel D'A'$, since the sum of the internal angles along the same side of the transversal $A'D$ is 180° . Since we already have $AD \parallel A'D$, the quadrilateral $AD'A'D$ is actually a parallelogram.

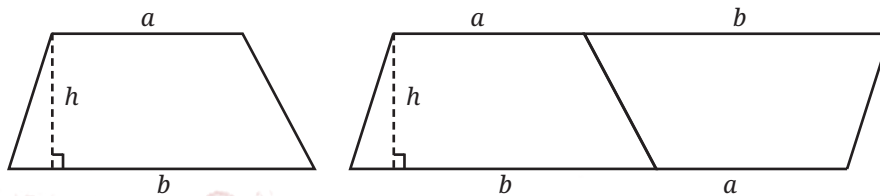

$$\begin{aligned} \text{Area of the trapezium} &= \frac{1}{2} \times \text{Area of the parallelogram} \\ &= \frac{1}{2} h(a + b). \end{aligned}$$

? Figure it Out

1. Find the area of a rhombus whose diagonals are 20 cm and 15 cm.
2. Give a method to convert a rectangle into a rhombus of equal area using dissection.
3. Find the areas of the following figures:

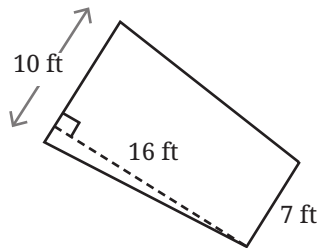

(i)

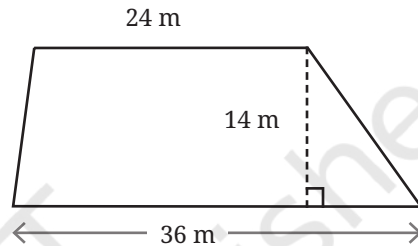

(ii)

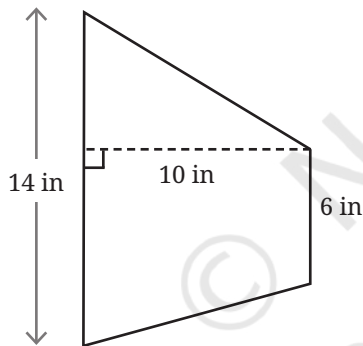

(iii)

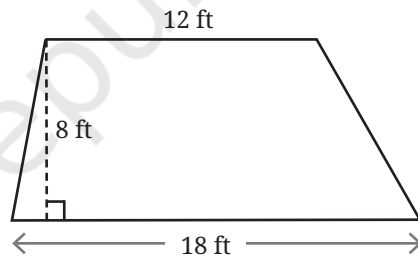

(iv)

4. [Śulba-Sūtras] Give a method to convert an isosceles trapezium to a rectangle using dissection.
5. Here is one of the ways to convert trapezium ABCD into a rectangle EFGH of equal area —

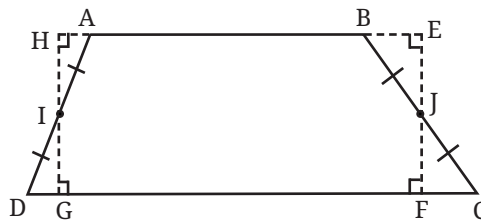

Given the trapezium ABCD, how do we find the vertices of the rectangle EFGH?

[Hint: If $\triangle AHI \cong \triangle DGI$ and $\triangle BEJ \cong \triangle CFJ$, then the trapezium and rectangle have equal areas.]



6. Using the idea of converting a trapezium into a rectangle of equal area, and vice versa, construct a trapezium of area 144 cm^2 .

7. A regular hexagon is divided into a trapezium, an equilateral triangle, and a rhombus, as shown. Find the ratio of their areas.

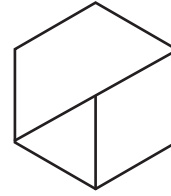

8. ZYXW is a trapezium with $ZY \parallel WX$. A is the midpoint of XY. Show that the area of the trapezium ZYXW is equal to the area of ΔZWB .

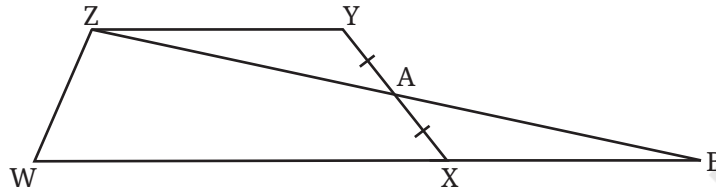

Areas in Real Life

? What do you think is the area of an A4 sheet?
Its sidelengths are 21 cm and 29.7 cm. Now find its area.

? What do you think is the area of the tabletop that you use at school or at home? You could perhaps try to visualise how many A4 sheets can fit on your table.

The dimensions of furniture like tables and chairs are sometimes measured in inches (in) and feet (ft).

$$1 \text{ in} = 2.54 \text{ cm}$$

$$1 \text{ ft} = 12 \text{ in}$$

? Express the following lengths in centimeters:

- (i) 5 in (ii) 7.4 in

? Express the following lengths in inches:

- (i) 5.08 cm (ii) 11.43 cm

? How many cm^2 is 1 in^2 ?

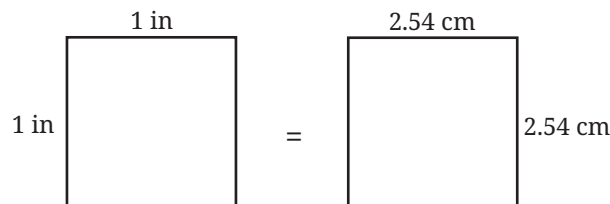

170 So, $1 \text{ in}^2 = 2.54^2 \text{ cm}^2 = 6.4516 \text{ cm}^2$.

? How many cm^2 is 10 in^2 ?
 $10 \text{ in}^2 = 10 \times 6.4516 \text{ cm}^2 = 64.516 \text{ cm}^2$.

? Convert 161.29 cm^2 to in^2 .
 Every 6.4516 cm^2 gives an in^2 . Hence,
 $161.29 \text{ cm}^2 = \frac{161.29}{6.4516} \text{ in}^2$.

? Evaluate the quotient.

? What do you think is the area of your classroom?
 Areas of classroom, house, etc., are generally measured in ft^2 or m^2 .

? How many in^2 is 1 ft^2 ?

? What do you think is the area of your school? Make an estimate and compare it with the actual data.
 Larger areas of land are also measured in acres.

$$1 \text{ acre} = 43,560 \text{ ft}^2$$

Besides these units, different parts of India use different local units for measuring area, such as *bigha*, *gaj*, *katha*, *dhur*, *cent*, *ankanam*, etc.

? Find out the local unit of area measurement in your region.

? What do you think is the area of your village/town/city? Make an estimate and compare it with the actual data.
 Larger areas are measured in km^2 .

? How many m^2 is a km^2 ?

? How many times is your village/town/city bigger than your school?

? Find the city with the largest area in (i) India, and (ii) the world.

? Find the city with the smallest area in (i) India, and (ii) the world.

SUMMARY

- Area of a triangle = $\frac{1}{2} \times \text{base} \times \text{height}$.
- The area of any polygon can be evaluated by breaking it into triangles.
- Area of a parallelogram = $\text{base} \times \text{height}$.
- Area of a rhombus = $\frac{1}{2} \times \text{product of its diagonals}$.
- Area of a trapezium = $\frac{1}{2} \times \text{height} \times \text{sum of parallel sides}$.

LEARNING MATERIAL SHEETS

© NCERT
not to be republished

1	
2	
3	
4	
5	
6	
7	
8	
9	
10	
11	
12	
13	
14	
15	
16	
17	
18	
19	
20	
21	
22	
23	
24	

1	
2	
3	
4	
5	
6	
7	
8	
9	
10	
11	
12	
13	
14	
15	
16	
17	
18	
19	
20	
21	
22	
23	
24	

1	
2	
3	
4	
5	
6	
7	
8	
9	
10	
11	
12	
13	
14	
15	
16	
17	
18	
19	
20	
21	
22	
23	
24	

Isometric Grid

